

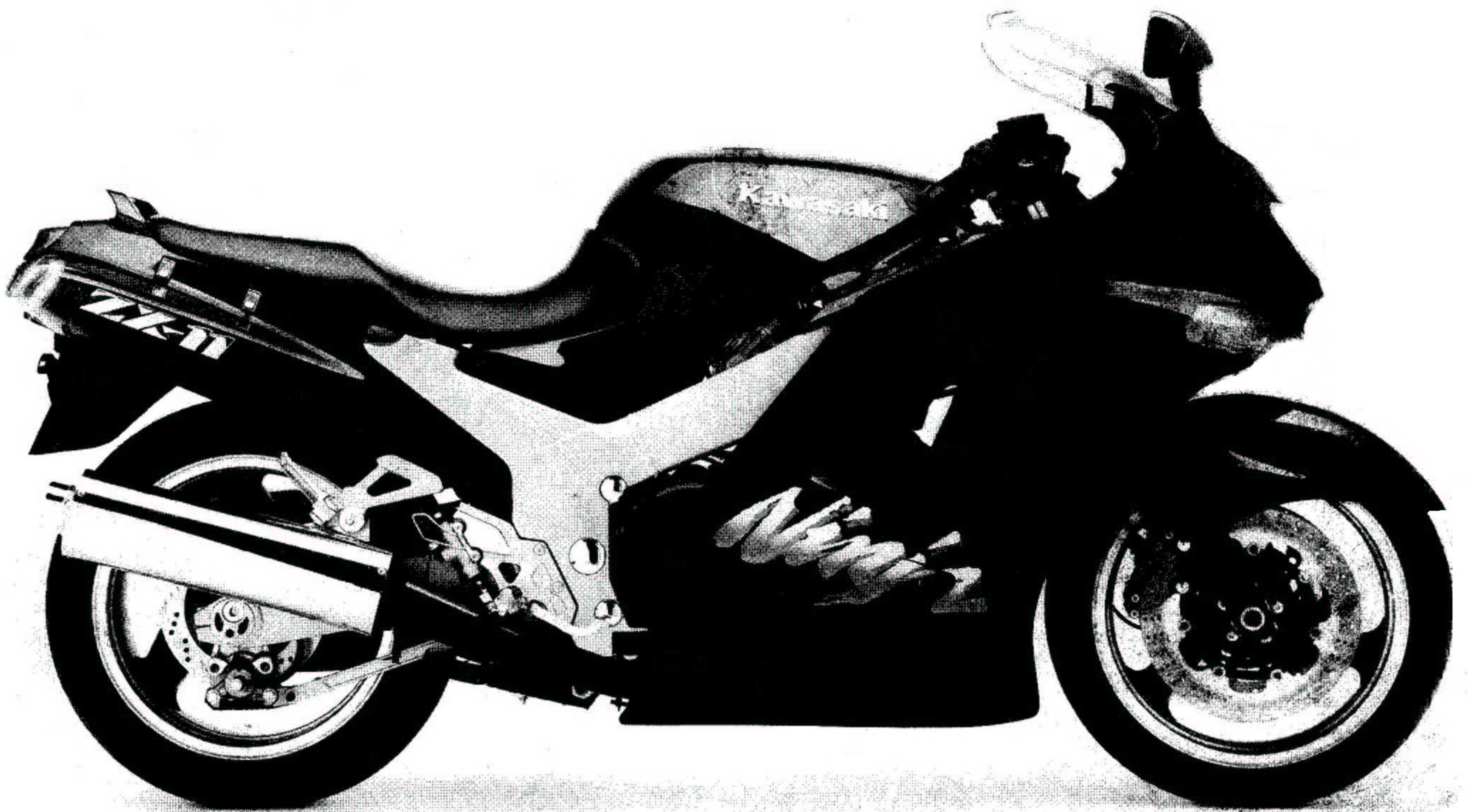

**Ninja ZX-11
ZZ-R1100**



**Motorcycle
Service Manual**



Ninja ZX-11
ZZ-R 1100

Motorcycle

Service Manual

All rights reserved. No parts of this publication may be reproduced, stored in a retrieval system, or transmitted in any form or by any means, electronic mechanical photocopying, recording or otherwise, without the prior written permission of Quality Assurance Department/Consumer Products Group/Kawasaki Heavy Industries, Ltd., Japan.

No liability can be accepted for any inaccuracies or omissions in this publication, although every possible care has been taken to make it as complete and accurate as possible.

The right is reserved to make changes at any time without prior notice and without incurring an obligation to make such changes to products manufactured previously. See your dealer for the latest information on product improvements incorporated after this publication.

All information contained in this publication is based on the latest product information available at the time of publication. Illustrations and photographs in this publication are intended for reference use only and may not depict actual model component parts.

Quick Reference Guide

General Information	1
Fuel System	2
Cooling System	3
Engine Top End	4
Clutch	5
Engine Lubrication System	6
Engine Removal/Installation	7
Crankshaft/Transmission	8
Wheels/Tires	9
Final Drive	10
Brakes	11
Suspension	12
Steering	13
Frame	14
Electrical System	15
Appendix	16

This quick reference guide will assist you in locating a desired topic or procedure.

- Bend the pages back to match the black tab of the desired chapter number with the black tab on the edge at each table of contents page.
- Refer to the sectional table of contents for the exact pages to locate the specific topic required.

LIST OF ABBREVIATIONS

A	ampere(s)	lb	pounds(s)
ABDC	after bottom dead center	m	meter(s)
AC	alternating current	min	minute(s)
ATDC	after top dead center	N	newton(s)
BBDC	before bottom dead center	Pa	pascal(s)
BDC	bottom dead center	PS	horsepower
BTDC	before top dead center	psi	pound(s) per square inch
°C	degree(s) Celsius	r	revolution
DC	direct current	rpm	revolution(s) per minute
F	farad(s)	TDC	top dead center
°F	degree(s) Fahrenheit	TIR	total indicator reading
ft	foot, feet	V	volt(s)
g	gram(s)	W	watt(s)
h	hour(s)	Ω	ohm(s)
L	liter(s)		



This warning may apply to any of the following components or any assembly containing one or more of these components:-

Brake Shoes or Pads
Clutch Friction Material
Gaskets
Insulators

SAFETY INSTRUCTIONS

- Operate if possible out of doors or in a well ventilated place.
- Preferably use hand tools or low speed tools equipped, if necessary, with an appropriate dust extraction facility. If high speed tools are used, they should always be so equipped.
- If possible, dampen before cutting or drilling.
- Dampen dust and place it in properly closed receptacle and dispose of it safely.

Read OWNER'S MANUAL before operating.

EMISSION CONTROL INFORMATION

To protect the environment in which we all live, Kawasaki has incorporated crankcase emission (1) and exhaust emission (2) control systems in compliance with applicable regulations of the United States Environmental Protection Agency and California Air Resources Board. Additionally, Kawasaki has incorporated an evaporative emission control system (3) in compliance with applicable regulations of the California Air Resources Board on vehicles sold in California only.

1. Crankcase Emission Control System

This system eliminates the release of crankcase vapors into the atmosphere. Instead, the vapors are routed through an oil separator to the intake side of the engine. While the engine is operating, the vapors are drawn into combustion chamber, where they are burned along with the fuel and air supplied by the carburetion system.

2. Exhaust Emission Control System

This system reduces the amount of pollutants discharged into the atmosphere by the exhaust of this motorcycle. The fuel and ignition systems of this motorcycle have been carefully designed and constructed to ensure an efficient engine with low exhaust pollutant levels.

3. Evaporative Emission Control System

Vapors caused by fuel evaporation in the fuel system are not vented into the atmosphere. Instead, fuel vapors are routed into the running engine to be burned, or stored in a canister when the engine is stopped. Liquid fuel is caught by a vapor separator and returned to the fuel tank.

The Clean Air Act, which is the Federal law covering motor vehicle pollution, contains what is commonly referred to as the Act's "tampering provisions."

"Sec. 203(a) The following acts and the causing thereof are prohibited...

(3)(A) for any person to remove or render inoperative any device or element of design installed on or in a motor vehicle or motor vehicle engine in compliance with regulations under this title prior to its sale and delivery to the ultimate purchaser, or for any manufacturer or dealer knowingly to remove or render inoperative any such device or element of design after such sale and delivery to the ultimate purchaser.

(3)(B) for any person engaged in the business of repairing, servicing, selling, leasing, or trading motor vehicles or motor vehicle engines, or who operates a fleet of motor vehicles knowingly to remove or render inoperative any device or element of design installed on or in a motor vehicle or motor vehicle engine in compliance with regulations under this title following its sale and delivery to the ultimate purchaser..."

(Continued on next page.)

NOTE

- *The phrase "remove or render inoperative any device or element of design" has been generally interpreted as follows:*
 1. *Tampering does not include the temporary or rendering inoperative of devices or elements of design in order to perform maintenance.*
 2. *Tampering could include:*
 - a. *Maladjustment of vehicle components such that the emission standards are exceeded.*
 - b. *Use of replacement parts or accessories which adversely affect the performance or durability of the motorcycle.*
 - c. *Addition of components or accessories that result in the vehicle exceeding the standards.*
 - d. *Permanently removing, disconnecting, or rendering inoperative any component or element of design of the emission control systems.*

WE RECOMMEND THAT ALL DEALERS OBSERVE THESE PROVISIONS OF FEDERAL LAW, THE VIOLATION OF WHICH IS PUNISHABLE BY CIVIL PENALTIES NOT EXCEEDING \$10,000 PER VIOLATION.

TAMPERING WITH NOISE CONTROL SYSTEM PROHIBITED

Federal law prohibits the following acts or the causing thereof: (1) The removal or rendering inoperative by any person other than for purposes of maintenance, repair, or replacement, of any device or element of design incorporated into any new vehicle for the purpose of noise control prior to its sale or delivery to the ultimate purchaser or while it is in use, or (2) the use of the vehicle after such device or element of design has been removed or rendered inoperative by any person.

Among those acts presumed to constitute tampering are the acts listed below:

- Replacement of the original exhaust system or muffler with a component not in compliance with Federal regulations.
- Removal of the muffler(s) or any internal portion of the muffler(s).
- Removal of the air box or air box cover.
- Modifications to the muffler(s) or air intake system by cutting, drilling, or other means if such modifications result in increased noise levels.

Foreword

This manual is designed primarily for use by trained mechanics in a properly equipped shop. However, it contains enough detail and basic information to make it useful to the owner who desires to perform his own basic maintenance and repair work. A basic knowledge of mechanics, the proper use of tools, and workshop procedures must be understood in order to carry out maintenance and repair satisfactorily. Whenever the owner has insufficient experience or doubts his ability to do the work, all adjustments, maintenance, and repair should be carried out only by qualified mechanics.

In order to perform the work efficiently and to avoid costly mistakes, read the text, thoroughly familiarize yourself with the procedures before starting work, and then do the work carefully in a clean area. Whenever special tools or equipment are specified, do not use makeshift tools or equipment. Precision measurements can only be made if the proper instruments are used, and the use of substitute tools may adversely affect safe operation.

For the duration of the warranty period, we recommend that all repairs and scheduled maintenance be performed in accordance with this service manual. Any owner maintenance or repair procedure not performed in accordance with this manual may void the warranty.

To get the longest life out of your motorcycle:

- Follow the Periodic Maintenance Chart in the Service Manual.
- Be alert for problems and non-scheduled maintenance.
- Use proper tools and genuine Kawasaki Motorcycle parts. Special tools, gauges, and testers that are necessary when servicing Kawasaki motorcycles are introduced by the Special Tool Manual. Genuine parts provided as spare parts are listed in the Parts Catalog.
- Follow the procedures in this manual carefully. Don't take shortcuts.
- Remember to keep complete records of maintenance and repair with dates and any new parts installed.

How to Use This Manual

In preparing this manual, we divided the product into its major systems. These systems became the manual's chapters. All information for a particular system from adjustment through disassembly and inspection is located in a single chapter.

The Quick Reference Guide shows you all of the product's system and assists in locating their chapters. Each chapter in turn has its own comprehensive Table of Contents.

The Periodic Maintenance Chart is located in the General Information chapter. The chart gives a time schedule for required maintenance operations.

If you want spark plug information, for example, go to the Periodic Maintenance Chart first. The chart tells you how frequently to clean and gap the plug. Next, use the Quick Reference Guide to locate the Electrical System chapter. Then, use the Table of Contents on the first page of the chapter to find the Spark Plug section.

Whenever you see these WARNING and CAUTION symbols, heed their instructions! Always follow safe operating and maintenance practices.

WARNING

This warning symbol identifies special instructions or procedures which, if not correctly followed, could result in personal injury, or loss of life.

CAUTION

This caution symbol identifies special instructions or procedures which, if not strictly observed, could result in damage to or destruction of equipment.

This manual contains four more symbols (in addition to WARNING and CAUTION) which will help you distinguish different types of information.

NOTE

- *This note symbol indicates points of particular interest for more efficient and convenient operation.*
- Indicates a procedural step or work to be done.
- Indicates a procedural sub-step or how to do the work of the procedural step it follows. It also precedes the text of a NOTE.
- ★ Indicates a conditional step or what action to take based on the results of the test or inspection in the procedural step or sub-step it follows.

In most chapters an exploded view illustration of the system components follows the Table of Contents. In these illustrations you will find the instructions indicating which parts require specified tightening torque, oil, grease or a locking agent during assembly.

General Information

Table of Contents

Before Servicing	1-2
Model Identification	1-4
General Specifications	1-5
Periodic Maintenance Chart	1-9
Torque and Locking Agent	1-10
Special Tools and Sealant	1-13
Cable, Wire, and Hose Routing	1-18

1-2 GENERAL INFORMATION

Before Servicing

Before starting to service a motorcycle, careful reading of the applicable section is recommended to eliminate unnecessary work. Photographs, diagrams, notes, cautions, warnings, and detailed descriptions have been included wherever necessary. Nevertheless, even a detailed account has limitations, a certain amount of basic knowledge is also required for successful work.

Especially note the following:

(1) Dirt

Before removal and disassembly, clean the motorcycle. Any dirt entering the engine or other parts will work as an abrasive and shorten the life of the motorcycle. For the same reason, before installing a new part, clean off any dust or metal filings.

(2) Battery Ground

Remove the ground (-) lead from the battery before performing any disassembly operations on the motorcycle. This prevents:

- (a) the possibility of accidentally turning the engine over while partially disassembled.
- (b) sparks at electrical connections which will occur when they are disconnected.
- (c) damage to electrical parts.

(3) Tightening Sequence

Generally, when installing a part with several bolts, nuts, or screws, start them all in their holes and tighten them to a snug fit. Then tighten them evenly in a cross pattern. This is to avoid distortion of the part and/or causing gas or oil leakage. Conversely when loosening the bolts, nuts, or screws, first loosen all of them by about a quarter turn and then remove them. Where there is a tightening sequence indication in this Service Manual, the bolts, nuts, or screws must be tightened in the order and method indicated.

(4) Torque

When torque values are given in this Service Manual, use them. Either too little or too much torque may lead to serious damage. Use a good quality, reliable torque wrench.

(5) Force

Common sense should dictate how much force is necessary in assembly and disassembly. If a part seems especially difficult to remove or install, stop and examine what may be causing the problem. Whenever tapping is necessary, tap lightly using a wooden or plastic-faced mallet. Use an impact driver for screws (particularly for the removal of screws held by a locking agent) in order to avoid damaging the screw heads.

(6) Edges

Watch for sharp edges, especially during major engine disassembly and assembly. Protect your hands with gloves or a piece of thick cloth when lifting the engine or turning it over.

(7) High-Flash Point Solvent

A high-flash point solvent is recommended to reduce fire danger. A commercial solvent commonly available in North America is Stoddard solvent (generic name). Always follow manufacturer and container directions regarding the use of any solvent.

(8) Gasket, O-Ring

Do not reuse a gasket or O-ring once it has been in service. The mating surfaces around the gasket should be free of foreign matter and perfectly smooth to avoid oil or compression leaks.

(9) Liquid Gasket, Non-Permanent Locking Agent

Follow manufacturer's directions for cleaning and preparing surfaces where these compounds will be used. Apply sparingly. Excessive amounts may block engine oil passages and cause serious damage. An example of a non-permanent locking agent commonly available in North America is Loctite Lock'n Seal (Blue).

(10) Press

A part installed using a press or driver, such as a wheel bearing, should first be coated with oil on its outer or inner circumference so that it will go into place smoothly.

(11) Ball Bearing and Needle Bearing

Do not remove any ball or needle bearings that are pressed in unless it is necessary. If they are removed, replace them with new ones.

When installing a bearing, press it in with the marked side facing out using a suitable driver until it is bottomed. Bearings should be pressed into place by pushing evenly the bearing race which is affected by friction.

(12) Oil Seal and Grease Seal

Replace any oil or grease seals that were removed with new ones, as removal generally damages seals. When pressing in a seal which has manufacturer's marks, press it in with the marks facing out. Seals should be pressed into place using a suitable driver, which contacts evenly with the side of seal, until the face of the seal is even with the end of the hole.

(13) Seal Guide

A seal guide is required for certain oil or grease seals during installation to avoid damage to the seal lips. Before a shaft passes through a seal, apply a little high temperature grease on the lips to reduce rubber to metal friction.

(14) Circlip, Retaining Ring

Replace any circlips and retaining rings that were removed with new ones, as removal weakens and deforms them. When installing circlips and retaining rings, take care to compress or expand them only enough to install them and no more.

(15) Cotter Pin

Replace any cotter pins that were removed with new ones, as removal deforms and breaks them.

(16) Lubrication

Engine wear is generally at its maximum while the engine is warming up and before all the rubbing surfaces have an adequate lubricative film. During assembly, oil or grease (whichever is more suitable) should be applied to any rubbing surface which has lost its lubricative film. Old grease and dirty oil should be cleaned off. Deteriorated grease has lost its lubricative quality and may contain abrasive foreign particles.

Don't use just any oil or grease. Some oils and greases in particular should be used only in certain applications and may be harmful if used in an application for which they are not intended. This manual makes reference to molybdenum disulfide grease (MoS_2) in the assembly of certain engine and chassis parts. Always check manufacturer recommendations before using such special lubricants.

(17) Electrical Wires

All the electrical wires are either single-color or two-color and, with only a few exceptions, must be connected to wires of the same color. On any of the two-color wires there is a greater amount of one color and a lesser amount of a second color, so a two-color wire is identified by first the primary color and then the secondary color. For example, a yellow wire with thin red stripes is referred to as a "yellow/red" wire; it would be a "red/yellow" wire if the colors were reversed to make red the main color.

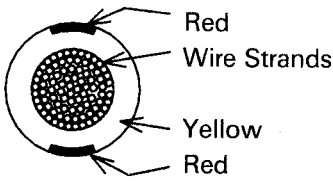
Wire (cross-section)	Name of Wire Color
 <p>The diagram shows a circular cross-section of a wire. The center is filled with a dense pattern of dots, representing the wire strands. This central core is surrounded by a thin outer layer. This layer is primarily yellow, but it has several thin, dark red stripes or bands around its circumference. Labels with arrows point to the 'Red' stripes, the 'Wire Strands' in the center, and the 'Yellow' outer jacket.</p>	<p>Yellow/Red</p>

(18) Replacement Parts

When there is a replacement instruction, replace these parts with new ones every time they are removed. These replacement parts will be damaged or lose their original function once removed.

(19) Inspection

When parts have been disassembled, visually inspect these parts for the following conditions or other damage. If there is any doubt as to the condition of them, replace them with new ones.

- | | | | |
|--------------|---------------|-----------|------|
| Abrasion | Crack | Hardening | Warp |
| Bent | Dent | Scratch | Wear |
| Color change | Deterioration | Seizure | |

(20) Specifications

Specification terms are defined as follows:

"Standards": Show dimensions or performances which brand-new parts or systems have.

"Service Limits": Indicate the usable limits. If the measurement shows excessive wear or deteriorated performance, replace the damaged parts.

1-4 GENERAL INFORMATION

Model Identification

ZX1100-D1 (US and Canadian Models) Left Side View:



ZX1100-D1 (US and Canadian Models) Right Side View:

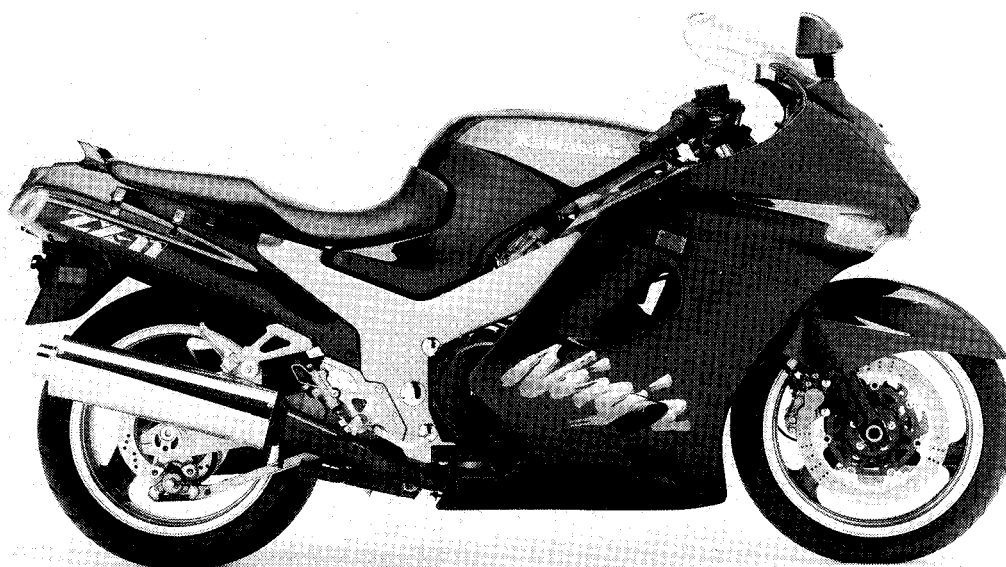

ZX1100-D1 (European Model) Left Side View:

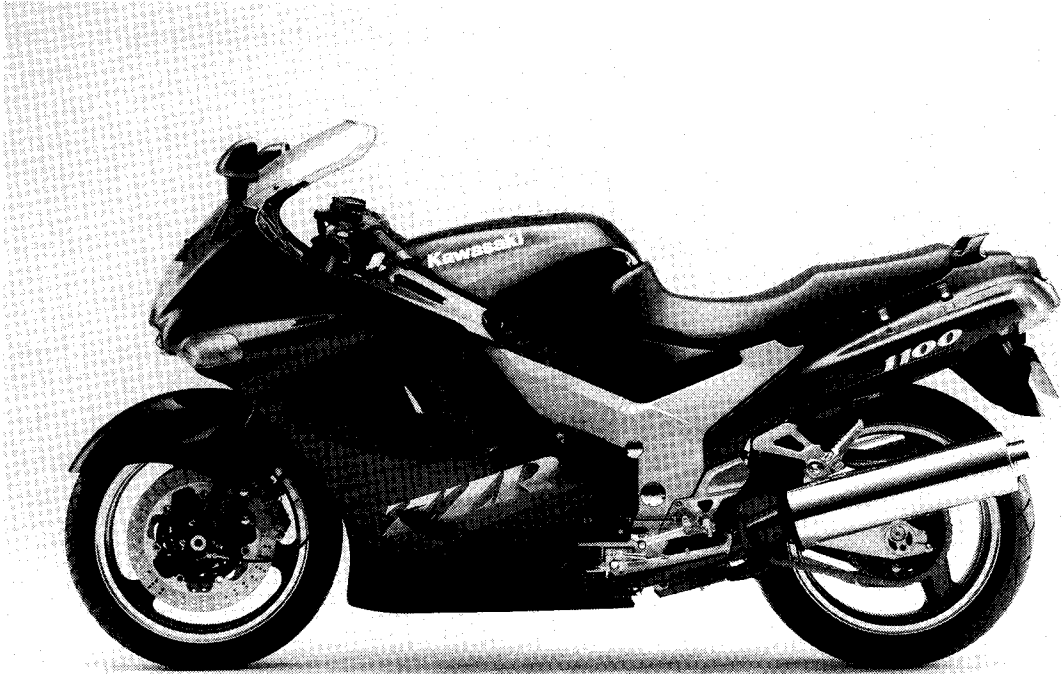

ZX1100-D1 (European Model) Right Side View:



1-6 GENERAL INFORMATION

General Specifications

Items	ZX1100-D1, D2, D3
Dimensions: Overall length Overall width Overall height Wheelbase Road clearance Seat height Dry mass Curb mass: Front Rear Fuel tank capacity	2 165 mm, (G) (N) (S) (Sw) 2 180 mm 730 mm 1 205 mm 1 495 mm, D3:(G) (F) (UK) (Gr) (N) 1 500 mm 110 mm 780 mm 233 kg, (Cal) 233.5 kg 130 kg 139 kg, (Cal) 139.5 kg 24.0 L
Performance: Minimum turning radius	3.0 m
Engine: Type Cooling system Bore and stroke Displacement Compression ratio Maximum horsepower Maximum torque Carburetion system Starting system Ignition system Timing advance Ignition timing	4-stroke, DOHC, 4-cylinder Liquid-cooled 76.0 x 58.0 mm 1052 mL 11.0 108 kW (147 PS) @10 500 r/min (rpm), (Ar) 74 kW (100 PS) @9 000 r/min (rpm), (F) 75.1 kW (-) @8 500 r/min (rpm) (UTAC'S norm), D3 : (F) 75.1 kW (-) @8 400 r/min (rpm) (UTAC'S norm), (S) 55 kW (75 PS) @6 000 r/min (rpm), (Sw) 68 kW (92 PS) @8 500 r/min (rpm), (U) - , (UK) 92 kW(-) @9 500 r/min (rpm) (ISO4106), (G) 74 kW (100 PS) @9 000 r/min (rpm) (DIN) 110 N-m(11.2 kg-m, 81 ft-lb) @8 500 r/min(rpm), (Ar) 90 N-m (9.2 kg-m, 67 ft-lb) @7 000 r/min (rpm), (F)(U)(UK) - , (S) 90 N-m (9.2 kg-m, 67 ft-lb) @5 500 r/min (rpm), (Sw) 86 N-m (8.8 kg-m, 64 ft-lb) @4 500 r/min (rpm), (G) 90 N-m (9.2 kg-m, 67 ft-lb) @7 000 r/min (rpm) (DIN) Carburetors, Keihin CVK-D 40 x 4 Electric starter Battery and coil (transistorized) Electronically advanced From 10° BTDC @1 000 r/min (rpm) to 40° BTDC @6 000 r/min (rpm) (Cal) From 7.5° BTDC @1 200 r/min (rpm) to 40° BTDC @6 000 r/min (rpm), (S) From 7.5° BTDC @1 300 r/min (rpm) to 40° BTDC @6 000 r/min (rpm) (U) From 7.5° BTDC @1 000 r/min (rpm) to 40° BTDC @6 000 r/min (rpm)

Items	ZX1100-D1, D2, D3
Spark plug Cylinder numbering method Firing order Valve timing: Inlet Open Close Duration Exhaust Open Close Duration Lubrication system Engine oil: Grade Viscosity Capacity	NGK CR9E or ND U27ESR-N Left to right, 1-2-3-4 1-2-4-3 40° BTDC,(F) 20° 70° ABDC,(F) 50° 290° (F) 250° 63° BBDC,(F) 45° 43° ATDC,(F) 25° 286° (F) 250° Forced lubrication (wet sump with cooler) SE, SF, or SG class SAE10W-40, 10W-50, 20W-40, or 20W-50 3.5 L
Drive Train: Primary reduction system: Type Reduction ratio Clutch type Transmission: Type Gear ratios: 1st 2nd 3rd 4th 5th 6th Final drive system: Type Reduction ratio Overall drive ratio	Gear 1.637 (95/58) Wet multi disc 6-speed, constant mesh, return shift 2.800 (42/15) 2.055 (37/18) 1.590 (35/22) 1.333 (32/24) 1.153 (30/26) 1.035 (29/28) Chain drive 2.647 (45/17), D3:(G) (F) (UK) (Gr) (N) 2.588 (44/17) 4.490 @Top gear, D3:(G) (F) (UK) (Gr) (N) 4.390 @Top gear
Frame: Type Caster (rake angle) Trail Front tire: Type Size Rear tire: Type Size Front suspension: Type Wheel travel Rear suspension: Type Wheel travel Brake type: Front Rear	Tubular, double cradle 26.5° 107 mm Tubeless 120/70 ZR17 Tubeless 180/55 ZR17 Telescopic fork 120 mm Swing arm (uni-trak) 112 mm Deal disc Single disc

1-8 GENERAL INFORMATION

Items	ZX1100-D1, D2, D3
Electrical Equipment:	
Battery	12 V 12 Ah
Headlight:	Semi-sealed beam
Type	12V60/55W (quartz-halogen)
Bulb	12 V 5/21 W × 2 (C)(Cal)(U) 12V8/27W × 2
Tail/brake light	Three-phase AC
Alternator:	28.6 A @6 000 r/min (rpm), 14 V
Type	
Rated output	

Specifications subject to change without notice, and may not apply to every country.

(AS) : Australian Model

(Ar) : Austrian Model

(C) : Canada model

(Cal) : California Model

(F) : France Model

(G) : Germany Model

(Gr) : Greece Model

(I) : Italy Model

(N) : Norway Model

(S) : Switzerland

(SA) : South Africa Model

(Sw) : Sweden Model

(U) : US Model

(UK) : UK Model

Periodic Maintenance Chart

The scheduled maintenance must be done in accordance with this chart to keep the motorcycle in good running condition. **The initial maintenance is vitally important and must not be neglected.**

OPERATION	FREQUENCY	Whichever comes first		† ODOMETER READING						
		Every	800 km	5000 km	10000 km	15000 km	20000 km	25000 km	30000 km	
Spark plug – clean			•	•	•	•	•	•		
Spark plug – check*			•	•	•	•	•	•		
Valve clearance – check*		•		•				•		
Air suction valve – check*			•	•	•	•	•	•		
Air cleaner element and air vent filter – clean		•		•				•		
Air cleaner element and air vent filter – replace	5 cleaning					•				
Throttle grip play--check*		•		•		•		•		
Idle speed – check*		•	•	•	•	•	•	•		
Engine vacuum synchronization -check *		•	•	•	•	•	•	•		
Fuel system--check *				•		•		•		
Coolant – change	2 years						•			
Evaporative emission control system (Cal) – check*		•	•	•	•	•	•	•		
Engine oil – change	year	•		•		•		•		
Oil filter –replace		•		•		•		•		
Radiator hoses, connections – check*	year	•		•		•		•		
Fuel filter – replace			•		•		•			
Fuel hose – replace	4 years									
Clutch fluid level – check *	month	•	•	•	•	•	•	•		
Clutch fluid – change	2 years					•				
Clutch hose and pipe – replace	4 years									
Clutch master cylinder cup and dust seal –replace	2 years									
Clutch slave cylinder piston seal – replace	2 years									
Drive chain wear –check *			•	•	•	•	•	•		
Drive chain –lubricate	300 km									
Drive chain slack – check *	800 km									
Brake pad wear –check*			•	•	•	•	•	•		
Brake fluid level – check*	month	•	•	•	•	•	•	•		
Brake fluid – change	2 years					•				
Brake hose – replace	4 years									
Brake master cylinder cup and dust seal – replace	2 years									
Caliper piston seal and dust seal – replace	2 years									
Brake light switch – check*		•	•	•	•	•	•	•		
Steering – check*		•	•	•	•	•	•	•		
Steering stem bearing – lubricate	2 years					•				
Front fork oil – change							•			
Tire wear – check*			•	•	•	•	•	•		
Swing arm pivot, uni-trak linkage – lubricate				•		•		•		
Battery electrolyte level – check*	month	•	•	•	•	•	•	•		
General lubrication – perform			•	•	•	•	•	•		
Nuts, bolts, and fasteners tightness – check*		•		•		•		•		

† : For higher odometer readings, repeat at the frequency interval established here.

* : Replace, add, adjust, clean, or torque if necessary.

(Cal) : California Model only

Fastener	Torque			Remarks
	N-m	kg-m	ft-lb	
Oil pipe banjo bolts(12 mm dia.)	25	2.5	18.0	
Oil pimp gear holder screws	-	-	-	L
Oil pump mounting bolts	12	1.2	104 in-lb	L
Oil filter bolt	20	2.0	14.5	
Engine Removal/Installation:				
Engine mounting nuts 8 mm	20	2.0	14.5	
10 mm	44	4.5	33	
Down tube mounting bolts	44	4.5	33	
Crankshaft/Transmission:				
Crankshaft cap bolts	32	3.3	24	
Balancer shaft guide pin plate bolt	-	-	-	L
Balancer shaft clamp lever mounting bolt	-	-	-	L
Alternator shaft chain tensioner bolts	-	-	-	L
Crankcase bolts: 9 mm dia.	32	3.3	24	S
8 mm dia.	27	2.8	20	
7 mm dia.	18	1.8	13.0	
6 mm dia.	15	1.5	11.0	
Connecting rod big end cap nuts				See p.8-11
Alternator shaft chain sprocket bolt	25	2.5	18.0	
Alternator shaft nut	59	6.0	43	
Alternator shaft bolt	25	2.5	18.0	
One-way clutch bolts	12	1.2	104 in-lb	L
Shift drum bearing holder bolts	-	-	-	L
External shift mechanism return spring pin	29	3.0	22	L
External shift mechanism cover bolts	9.8	1.0	87 in-lb	L(4)
Neutral switch	15	1.5	11.0	
Wheels/Tires:				
Front axle nut	145	15.0	110	
Front axle clamp bolts	20	2.0	14.5	
Rear axle nut	110	11.0	80	
Final Drive:				
Engine sprocket nut	125	13.0	94	
Engine sprocket cover damper bolts	-	-	-	L
Rear sprocket nuts	74	7.5	54	
Rear sprocket studs	-	-	-	L
Chain adjuster clamp bolts	39	4.0	29	
Brakes:				
Brake lever pivot nut	8.8	0.90	78 in-lb	
Front master cylinder clamp bolts	11	1.1	95 in-lb	S
Brake hose banjo bolts	25	2.5	18.0	
Bleed valves	7.8	0.80	69 in-lb	
Caliper mounting bolts : Front	34	3.5	25	
: Rear	25	2.5	18	
Front caliper assembly bolts	21	2.1	15.0	
Brake disc mounting bolts	23	2.3	16.5	
Brake pedal pivot bolt	8.8	0.90	78 in-lb	
Rear master cylinder mounting bolts	23	2.3	16.5	
Push rod nut	18	1.8	13.0	
Torque link bolts/nut	25	2.5	18.0	

1-12 GENERAL INFORMATION

Fastener	Torque			Remarks
	N-m	kg-m	ft-lb	
Suspension:				
Front fork top plugs	23	2.3	16.5	
Front fork clamp bolts(Upper)	28	2.9	21	
Front fork clamp nuts(Lower)	21	2.1	15.0	
Front fork bottom Allen bolts	61	6.2	45	L
Front axle clamp bolts	20	2.0	14.5	
Rear shock absorber mounting nuts	59	6.0	43	
Swing arm pivot nut	88	9.0	65	
Rocker arm pivot nut	59	6.0	43	
Tie-rod bolts	59	6.0	43	
Steering:				
Handlebar weight bolts	-	-	-	L
Handlebar holder bolts	20	2.0	14.5	
Steering stem head nut	39	4.0	29	
Steering stem nut	4.9	0.50	43 in-lb	
Frame:				
Downtube bolts	44	4.5	33	
Side stand switch screws	-	-	-	L
Center stand spring hook bolts	-	-	-	L
Side stand bracket mounting bolts	49	5.0	36	L
Side Stand Bolt	34	3.5	25	
Electrical System:				
Spark plugs	14	1.4	10.0	
Pickup coil cover bolts	-	-	-	L(2)
Timing rotor bolt	25	2.5	18.0	
Pickup coil holder bolts	-	-	-	L
Alternator mounting bolts	25	2.5	18.0	
Alternator coupling bolts	9.8	1.0	87 in-lb	
Alternator cover nuts	4.4	0.45	39 in-lb	
Alternator cover studs	8.8	0.90	78 in-lb	

The table below, relating tightening torque to thread diameter, lists the basic torque for the bolts and nuts. Use this table for only the bolts and nuts which do not require a specific torque value. All of the values are for use with dry solvent-cleaned threads.

Basic Torque for General Fasteners

Threads dia. (mm)	Torque		
	N-m	kg-m	ft-lb
5	3.4 ~ 4.9	0.35 ~ 0.50	30 ~ 43 in-lb
6	5.9 ~ 7.8	0.60 ~ 0.80	52 ~ 69 in-lb
8	14 ~ 19	1.4 ~ 1.9	10.0 ~ 13.5
10	25 ~ 34	2.6 ~ 3.5	19.0 ~ 25.0
12	44 ~ 61	4.5 ~ 6.2	33 ~ 45
14	73 ~ 98	7.4 ~ 10.0	54 ~ 72
16	115 ~ 155	11.5 ~ 16.0	83 ~ 115
18	165 ~ 225	17.0 ~ 23.0	125 ~ 165
20	225 ~ 325	23 ~ 33	165 ~ 240

Special Tools and Sealant

Bearing Puller Adapter: 57001-136

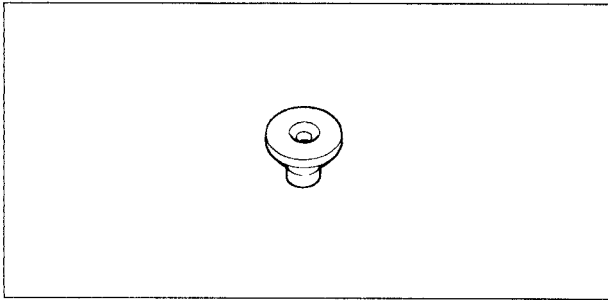

Compression Gauge: 57001-221

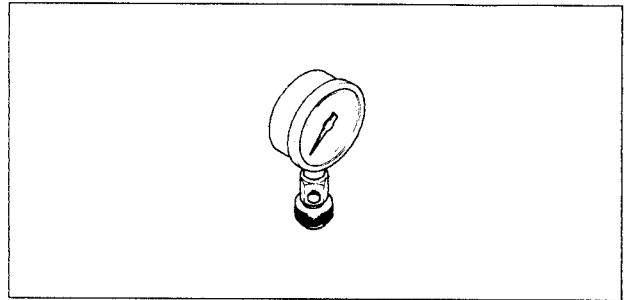

Steering Stem Bearing Driver: 57001-137

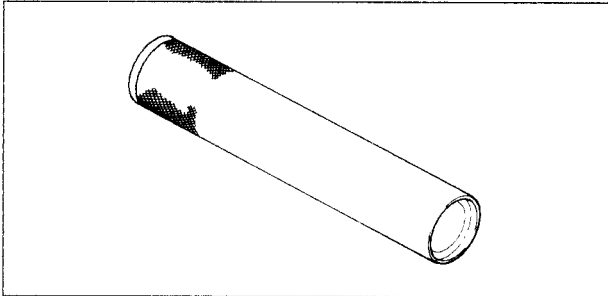

Valve Spring Compressor Assembly: 57001-241

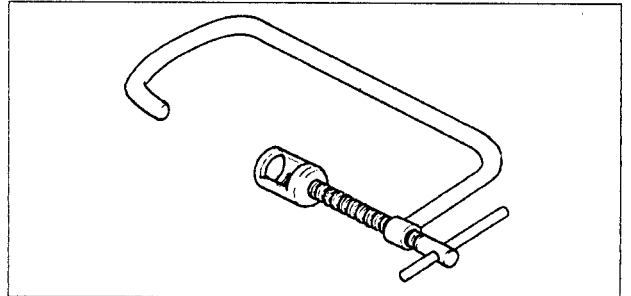

Inside Circlip Pliers: 57001-143

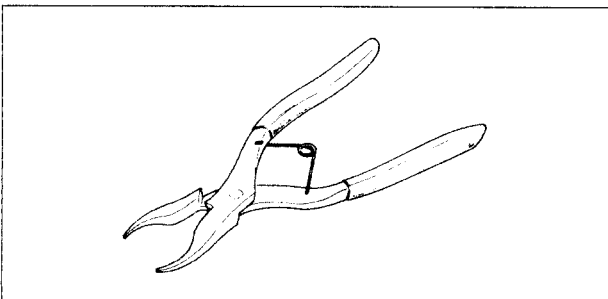

Bearing Puller Adapter: 57001-317

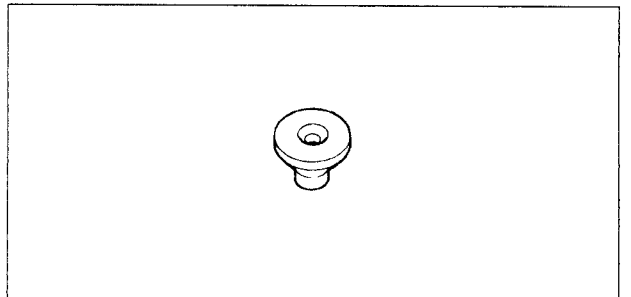

Bearing Puller: 57001-158

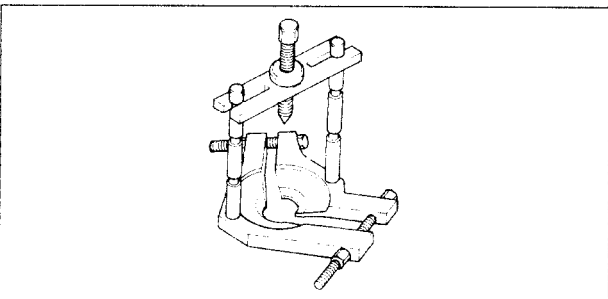

Piston Pin Puller Assembly: 57001-910

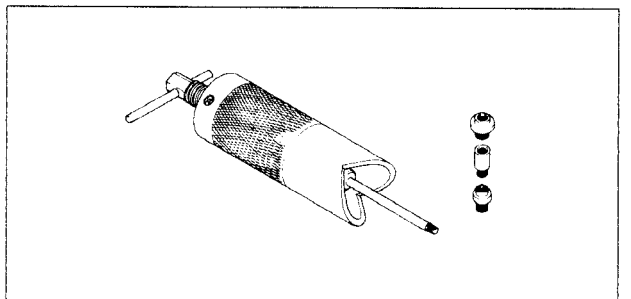

Fork Cylinder Holder Handle: 57001-183

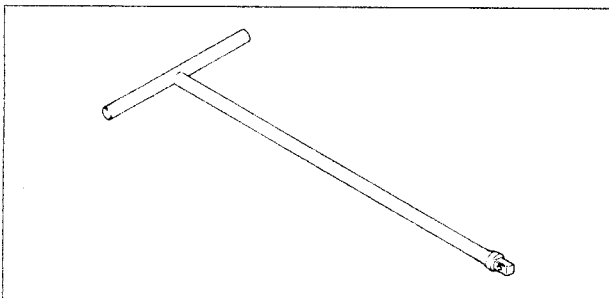

Hand Tester: 57001-983

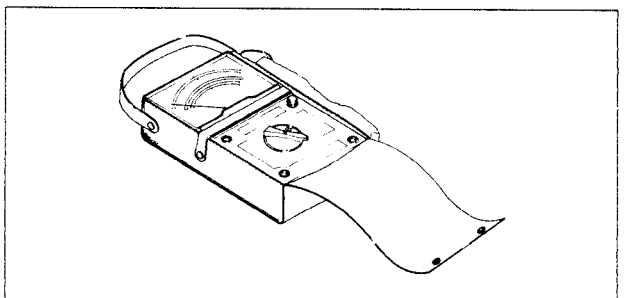

1-14 GENERAL INFORMATION

Oil Seal & Bearing Remover: 57001-1058

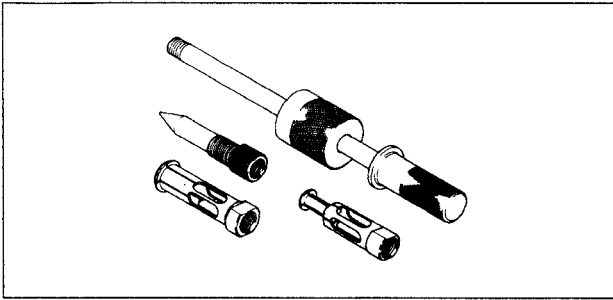

Piston Ring Compressor Grip: 57001-1095

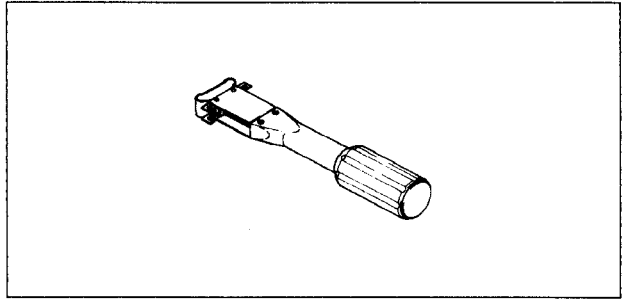

Steering Stem Bearing Driver Adapter: 57001-1074

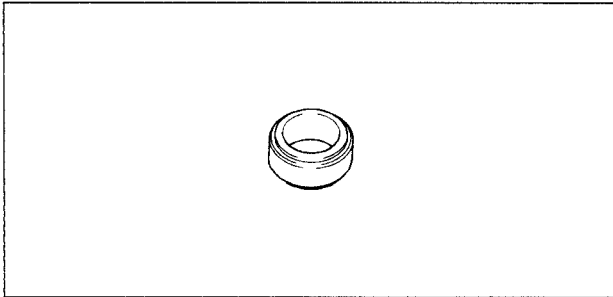

Piston Ring Compressor Belt, $\phi 67 \sim \phi 79$: 57001-1097

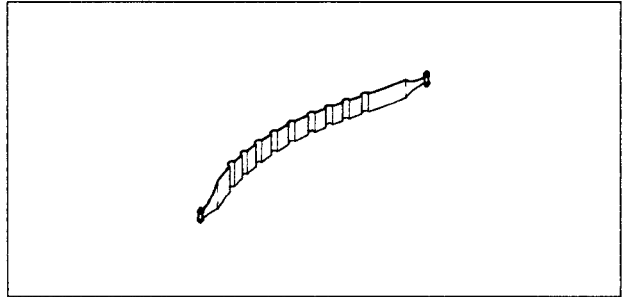

Head Pipe Outer Race Press Shaft: 57001-1075

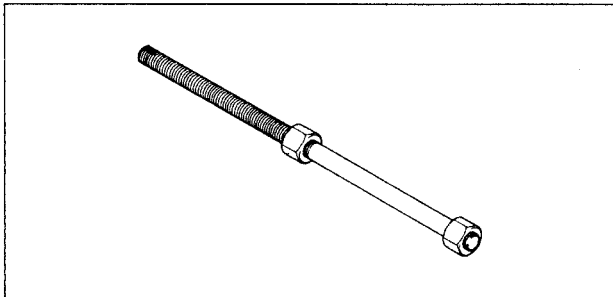

Steering Stem Nut Wrench: 57001-1100

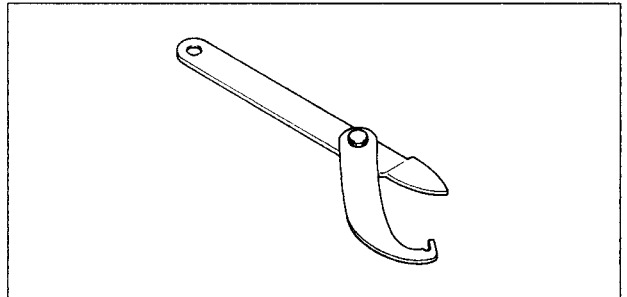

Head Pipe Outer Race Driver: 57001-1076

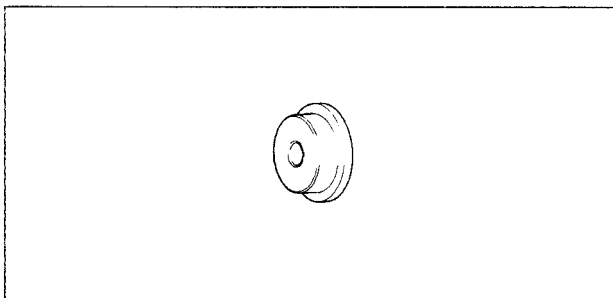

Head Pipe Outer Race Remover: 57001-1107

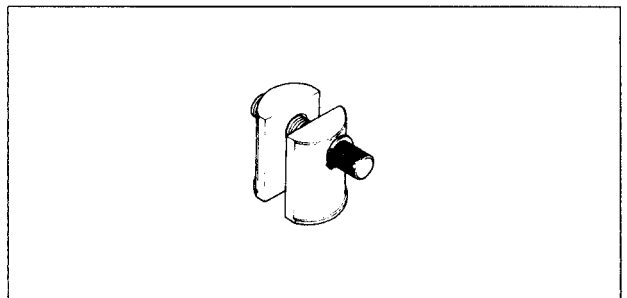

Head Pipe Outer Race Driver: 57001-1077

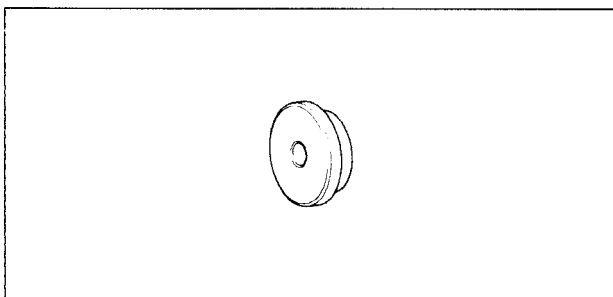

Valve Seat Cutter, $45^\circ - \phi 27.5$: 57001-1114

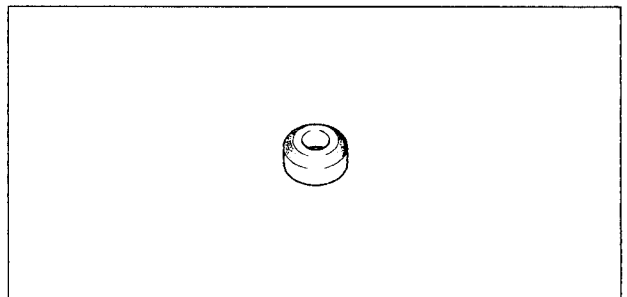

Valve Seat Cutter, 45° – ϕ 32: 57001-1115

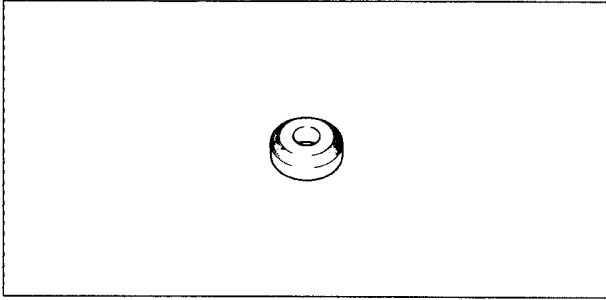

Valve Seat Cutter, 32° – ϕ 33: 57001-1199

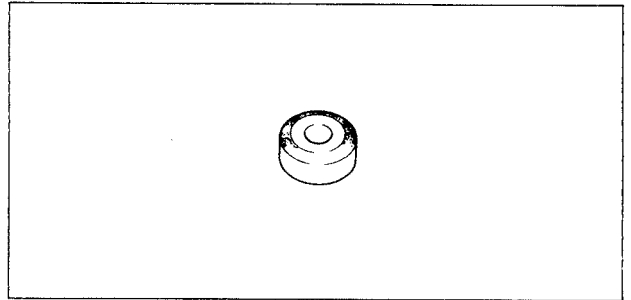

Valve Seat Cutter, 32° – ϕ 30: 57001-1120

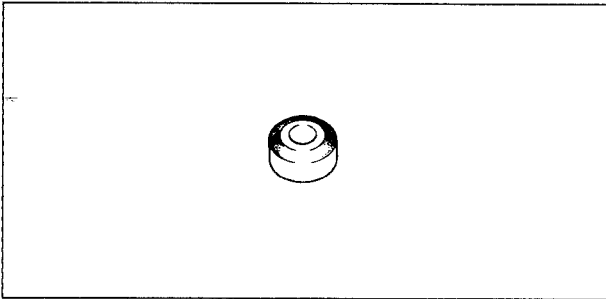

Valve Spring Compressor Adapter, ϕ 22: 57001-1202

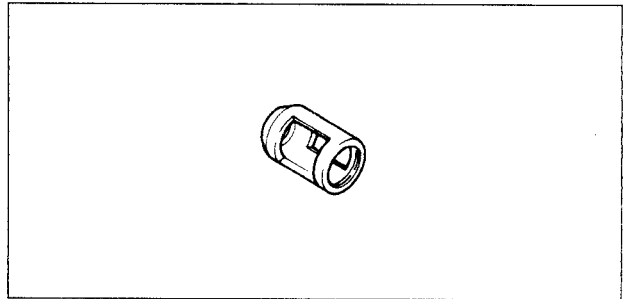

Valve Seat Cutter, 60° – ϕ 30: 57001-1123

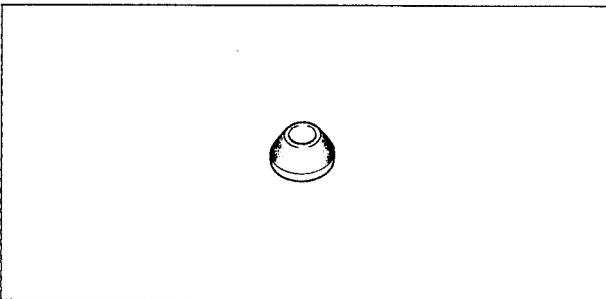

Valve Guide Arbor, ϕ 5: 57001-1203

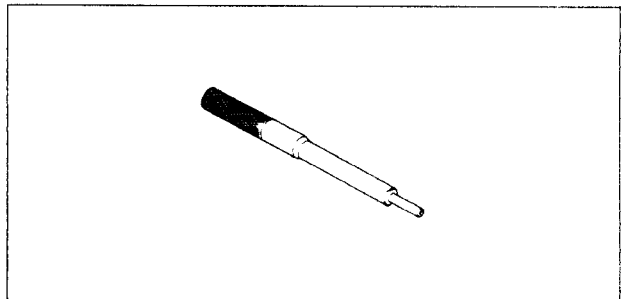

Valve Seat Cutter Holder Bar: 57001-1128

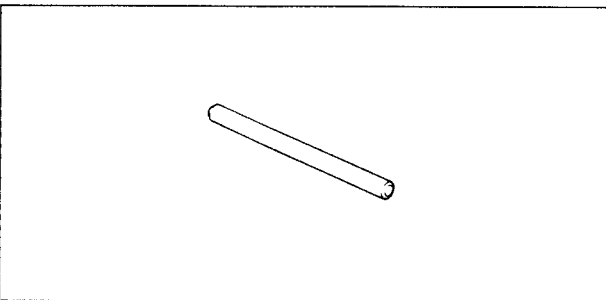

Valve Guide Reamer, ϕ 5: 57001-1204

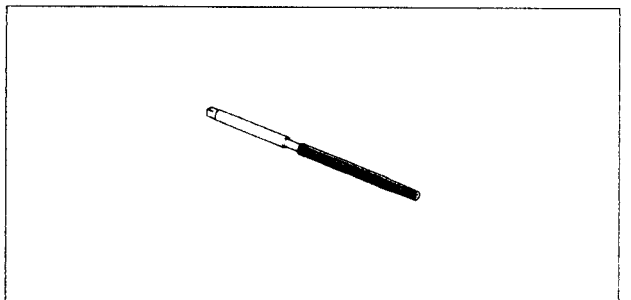

Bearing Driver Set: 57001-1129

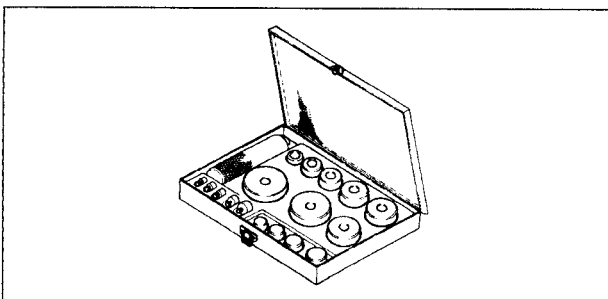

Valve Seat Cutter Holder, ϕ 5: 57001-1208

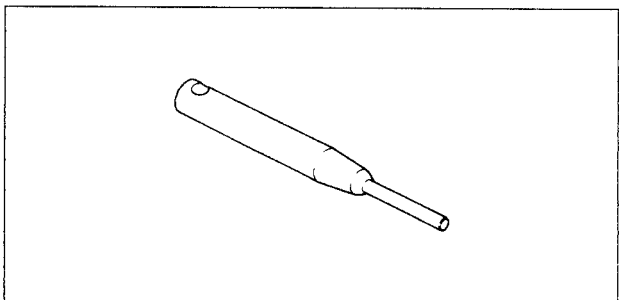

1-16 GENERAL INFORMATION

Fork Outer Tube Weight: 57001-1218

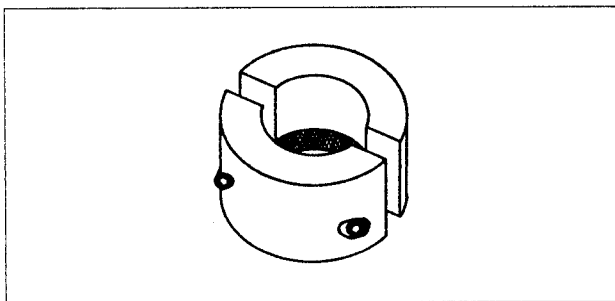

Piston Base, $\phi 6$: 57001-1263

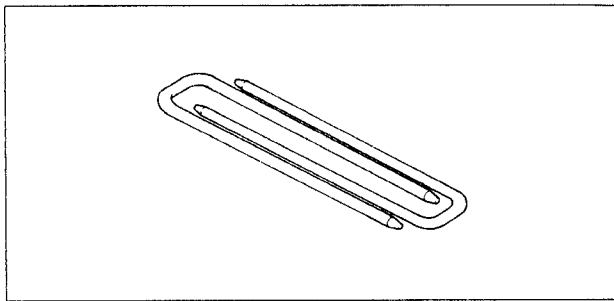

Front Fork Oil Seal Driver: 57001-1219

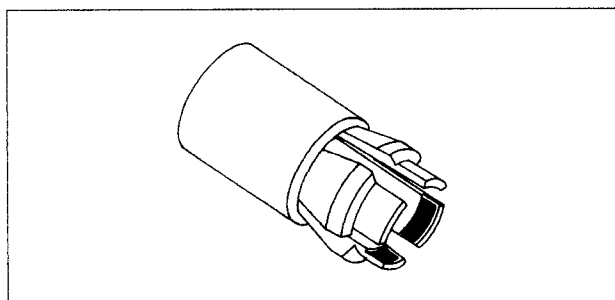

Bearing Remover Shaft: 57001-1265

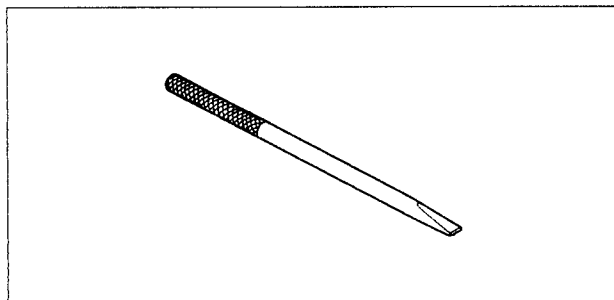

Coil Tester: 57001-1242

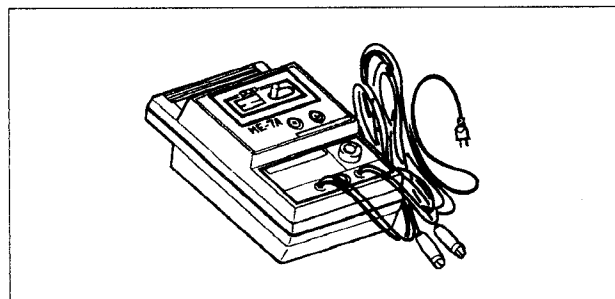

Bearing Remover Head, $\phi 15 \times \phi 17$: 57001-1267

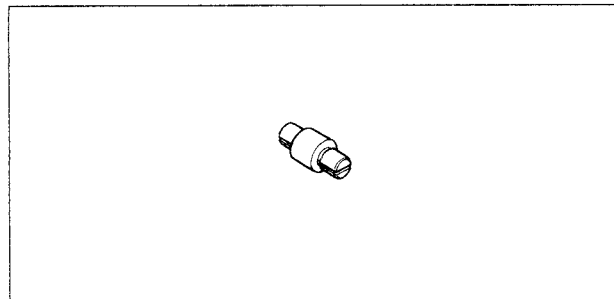

Spark Plug Wrench, Hex 16: 57001-1262

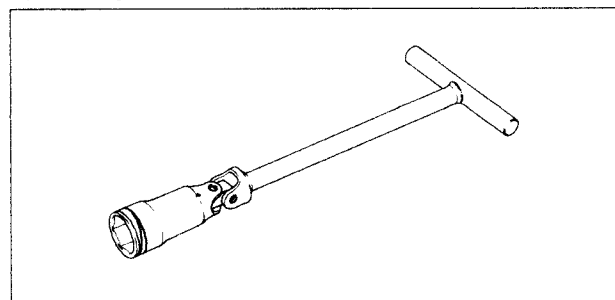

Fork Oil Level Gauge: 57001-1290

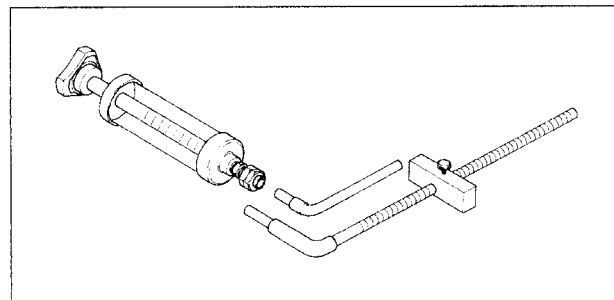

Jack: 57001-1238

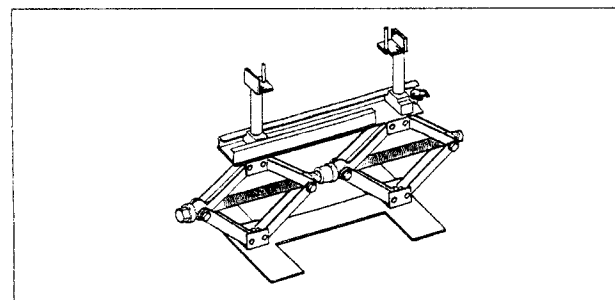

Bearing Remover Head, $\phi 20 \times \phi 22$: 57001-1293

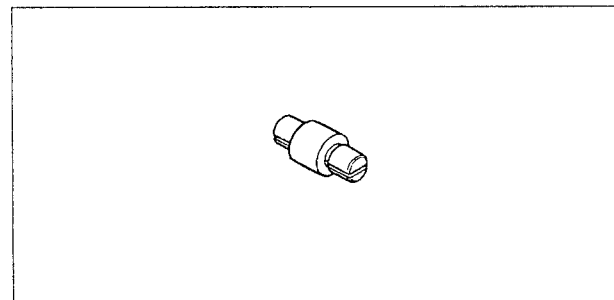

Compression Gauge Adapter, M10 X 1.0: 57001-1317

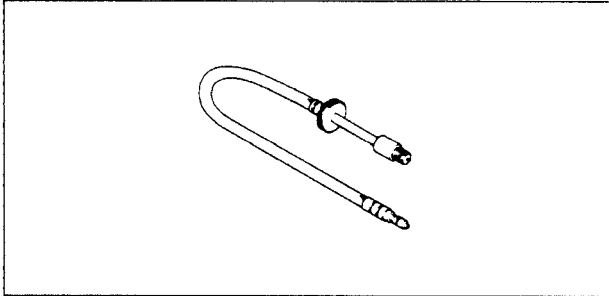

Kawasaki Bond (Liquid Gasket – Black): 92104-1003

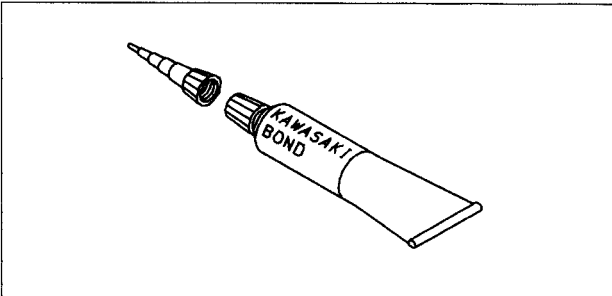

Valve Seat Cutter, 60° – ϕ 33: 57001-1334

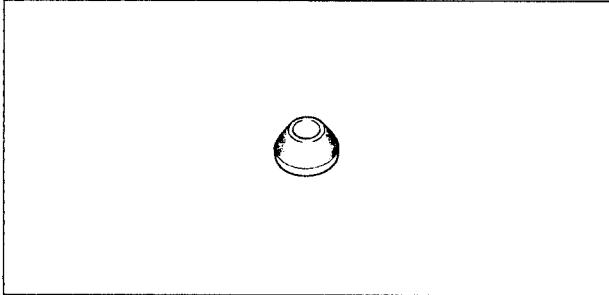

Hexagon Wrench, Hex 29: 57001-1335

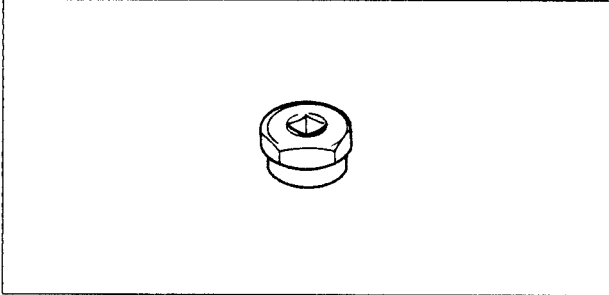

Vacuum Gauge: 57001-1369

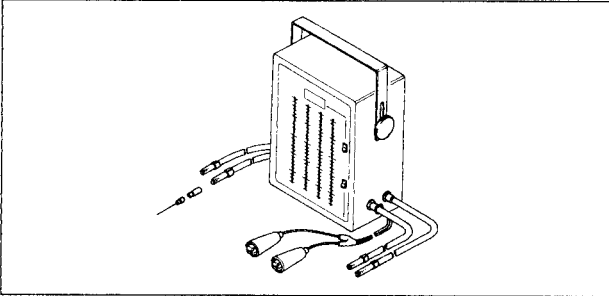

Kawasaki Bond (Silicone Sealant): 56019-120

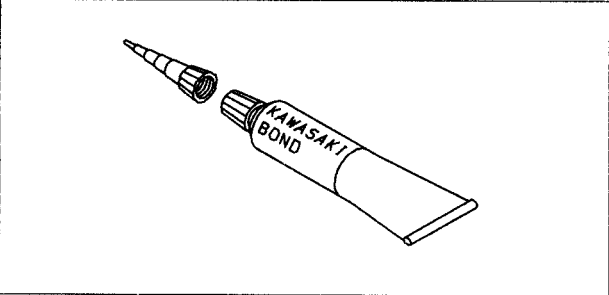

1-18 GENERAL INFORMATION

Cable, Wire, and Hose Routing

1. Cables passing in Left Hole
Throttle Cable
Choke Cable
Ignition Switch Leads
Left Switch Case Leads
2. Cable passing in Right Hole
Main Harness
Right Switch Case Leads

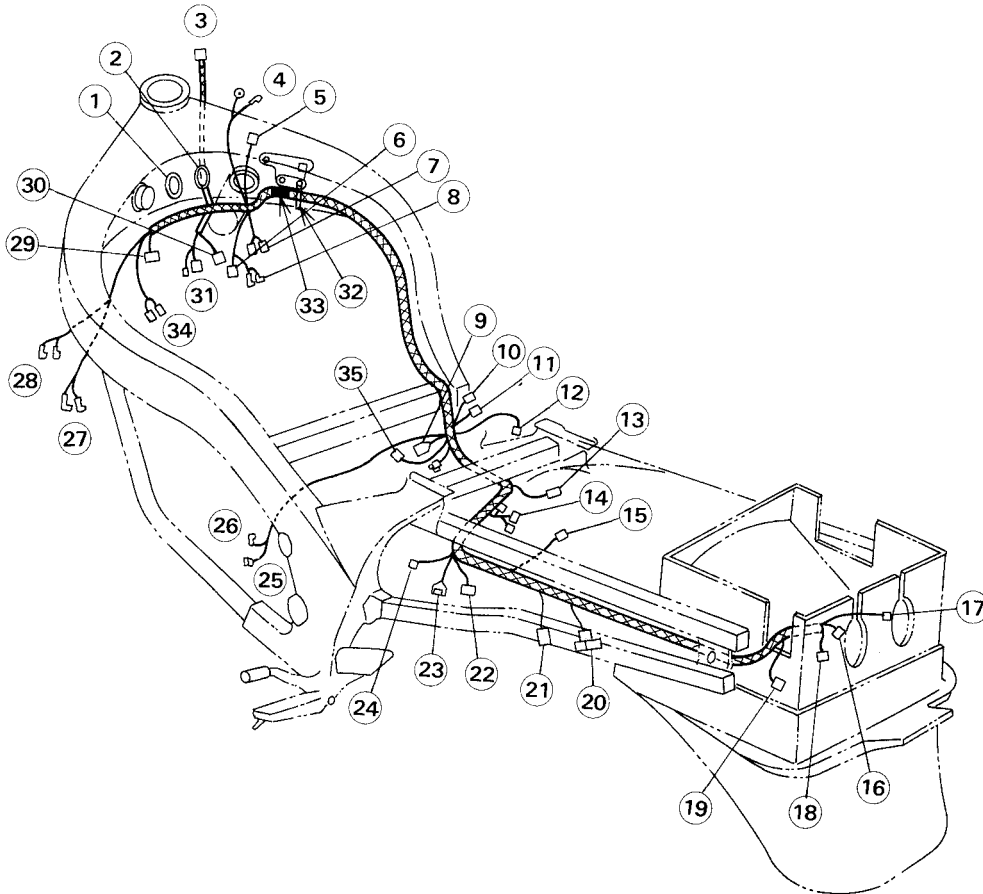

- | | | |
|------------------------------|----------------------------|--|
| 3. Main Harness | 15. Fuel Level Gauge Lead | 27. Cooling Fan Switch Lead |
| 4. Water Temp. Sensor Leads | 16. Tail/Brake Light Lead | 28. Left Horn Lead |
| 5. Ground Lead | 17. Right Turn Signal Lead | 29. Left Handlebar Switch Lead |
| 6. Fan Motor Lead | 18. Licence Light Lead | 30. Right Handlebar Switch Lead |
| 7. #2,3 Ignition Coil Leads | 19. Left Turn Signal Lead | 31. Ignition Switch Leads |
| 8. Right Horn Lead | 20. Turn Signal Relay Lead | 32. Clamp |
| 9. Alternator Lead | 21. Rectifier Lead | 33. White Color Tape Wound on Main Harness |
| 10. Pickup Coil Lead | 22. IC Igniter Lead | 34. #1, 4 Ignition Coil Leads |
| 11. Battery (-) Lead | 23. Starter Relay Lead | 35. Fuel Pump Lead |
| 12. Oil Pressure Switch Lead | 24. Fuel pump Relay lead | |
| 13. Rear Brake Switch Lead | 25. Side Stand Switch Lead | |
| 14. Junction Box Lead | 26. Neutral Switch Lead | |

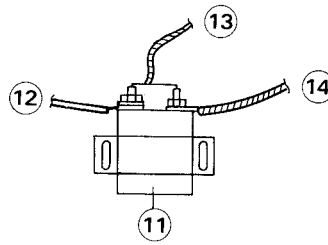
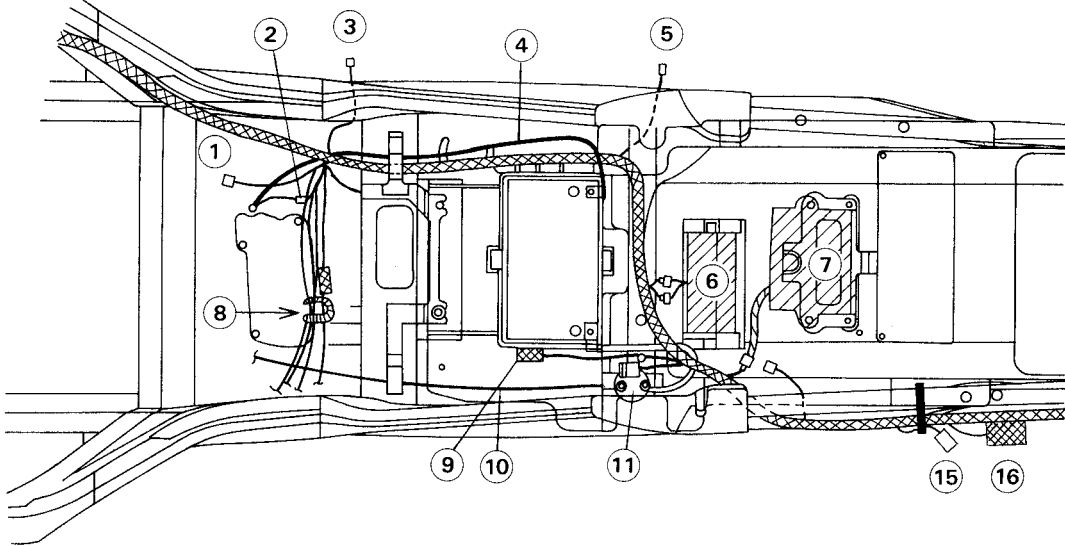

- 1. Fuel Pump Lead
- 2. Ground Lead
- 3. Oil Pressure Switch Lead
- 4. Battery (-) Lead
- 5. Rear Brake Switch Lead
- 6. Junction Box
- 7. Igniter

- 8. Clamp Following Leads
- Pickup Coil Lead
- Alternator Lead
- Neutral Switch Lead
- 9. Fuel Pump Relay
- 10. Starter Motor Lead
- 11. Starter Relay
- 12. To Starter Motor
- 13. Main Harness
- 14. Battery (+) Lead
- 15. Rectifier
- 16. Turn Signal Relay

Fairing Inside Harness Leads

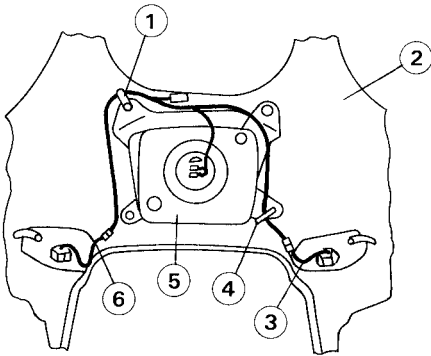

1. Clamp
2. Upper Fairing
3. Right Turn Signal Lead
4. Clamp
5. Headlight
6. Left Turn Signal Lead

Speedometer Lead

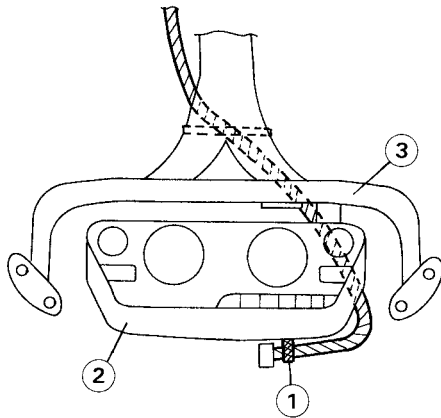

1. Clamp
2. Speedometer
3. Bracket
4. Band

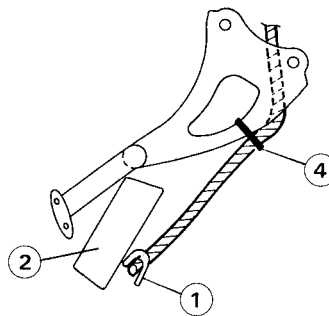

Frame Front Part Leads

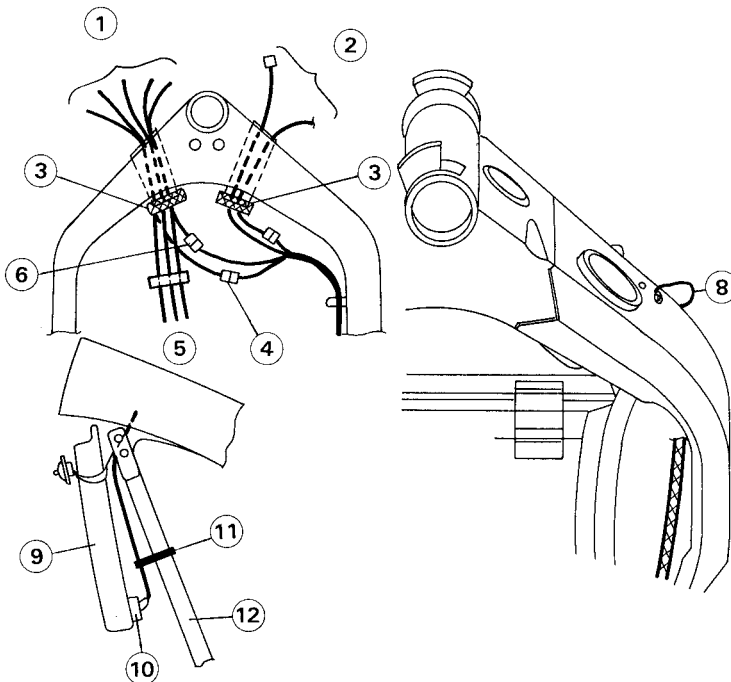

1. Cables passing in Left Hole
Throttle Cable
Choke Cable
Ignition Switch Leads
Left Handlebar Leads
2. Cable passing in Right Hole
Main Harness
Right Handlebar Leads
3. Guards
4. Ignition Switch Lead
5. Throttle and Choke Cables
6. Left Handlebar Switch Lead
7. Clamp
8. Ground Lead
9. Radiator
10. Fan Switch Lead
11. Band
12. Down Tube

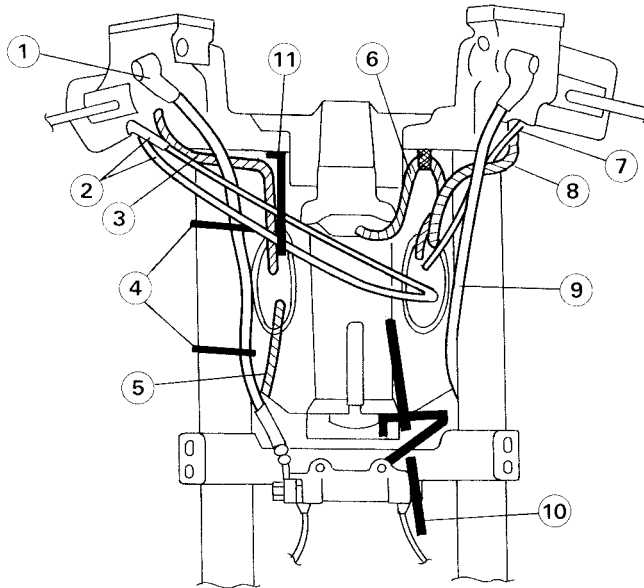

- 1. Front Brake Hose
- 2. Throttle Cables
- 3. Right Handlebar Switch Lead
- 4. Bands
- 5. Main Harness
- 6. Ignition Switch Lead
- 7. Choke Cable
- 8. Left Handlebar Switch Lead
- 9. Clutch Hose
- 10. Speedometer Cable
- 11. Clamp

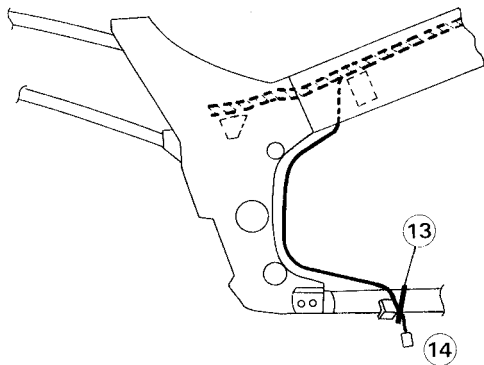

- 12. Side Stand Switch
- 13. Band
- 14. Oil Pressure Switch Lead

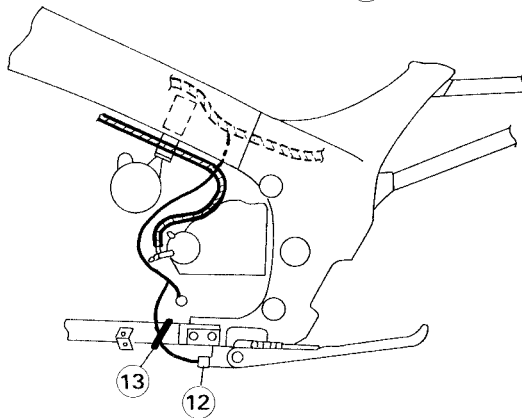

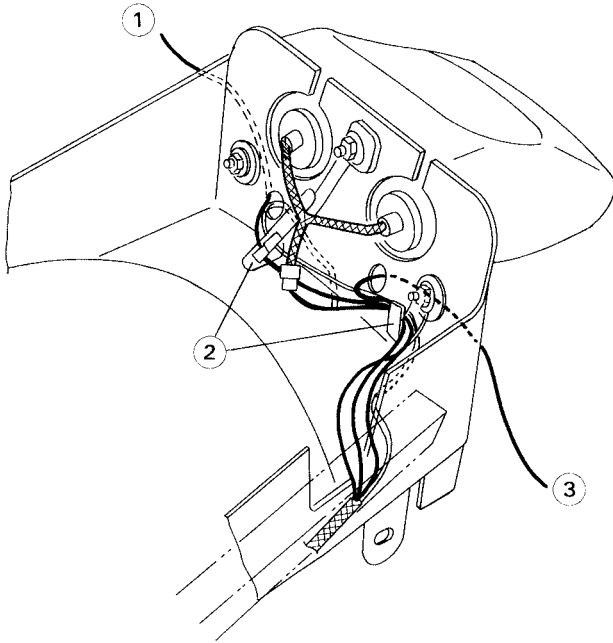

1. Right Rear Turn Signal Lead
2. Clamp
Tighten to the tail Light
3. Left Rear Turn Signal Lead

Ignition Coil Read

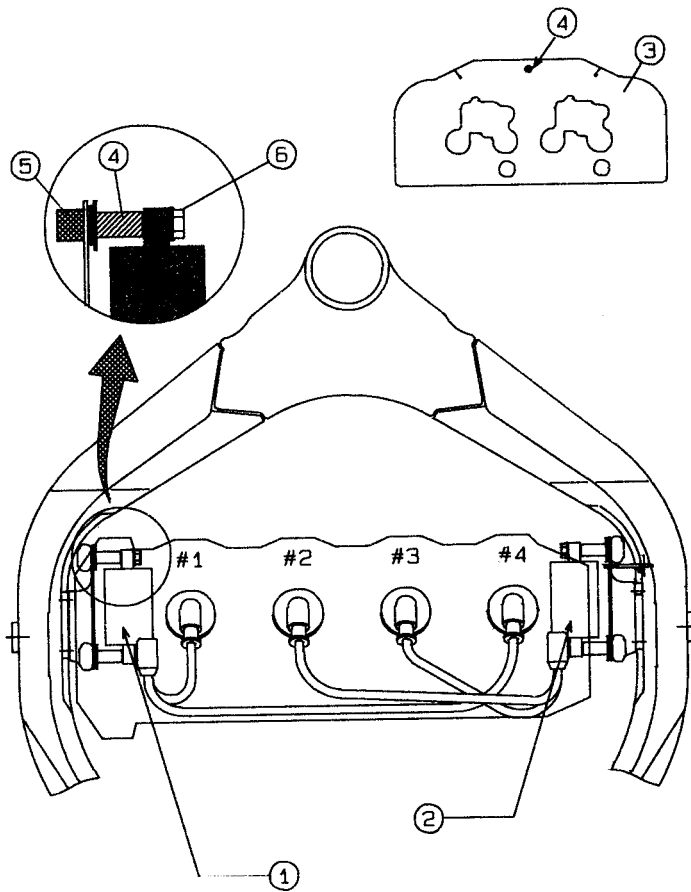

1. # 1, 4 Ignition Coil
2. # 2, 3 Ignition Coil
3. Heat Sealed
(White paint mark should be on top).
4. White paint
5. Bolt
6. Nut

Air Filter

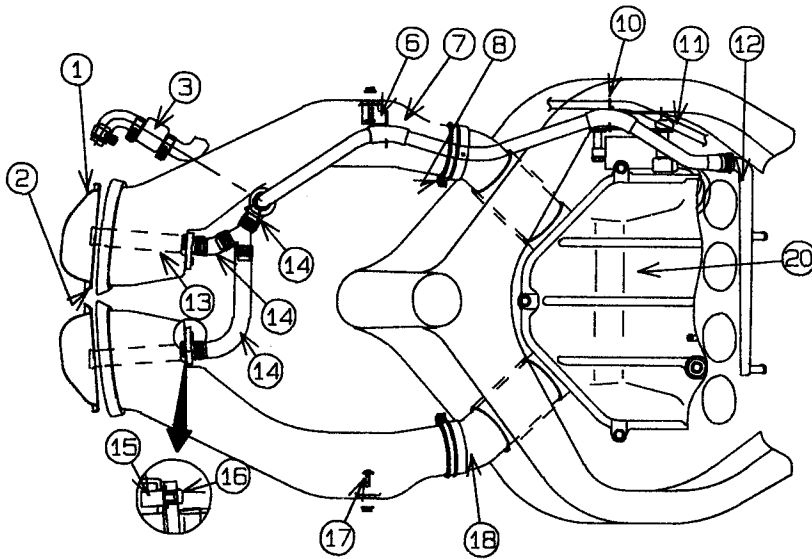

1. Screen
2. White paint ID mark for R.H.screen
3. Air Vent Filter
6. Clamp
7. Air Duct
8. Clump
10. Clamp
11. Reservoir Tank Hose
12. Pipe To #1, 4 Carburetors
13. Pipe
14. Tube
15. Nut
16. Screw
17. Screw
18. Duct ID Mark L or R mark should be up.
20. Air Cleaner Housing
21. Plugs
22. Front Drain Tube
23. Rear Drain Tube
24. Catch Tank
25. Plug

Vacuum Switch Valve (Other than California Model)

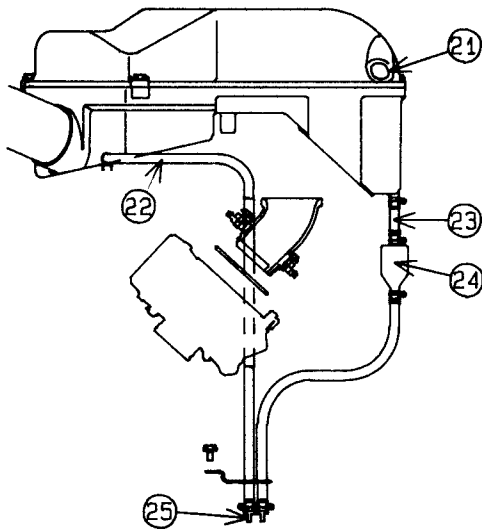

1. Vacuum Switch Valve
2. Vacuum Switch Valve Hose
3. To Bottom of Air Cleaner Housing
4. Vacuum Tube
5. To # 1 Carburetor Holder
6. To # 4 Carburetor Holder

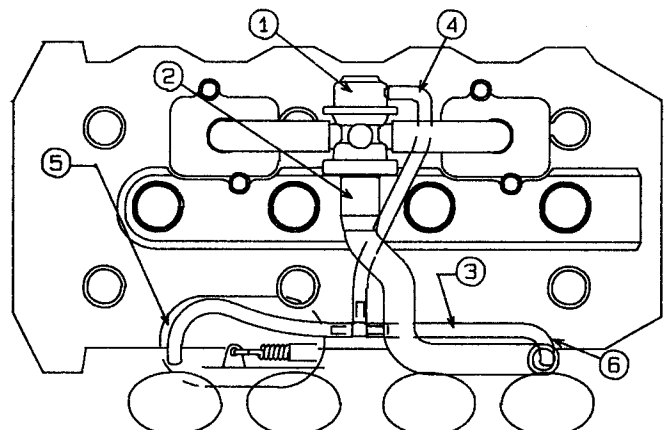

Fuel Pump Pipe

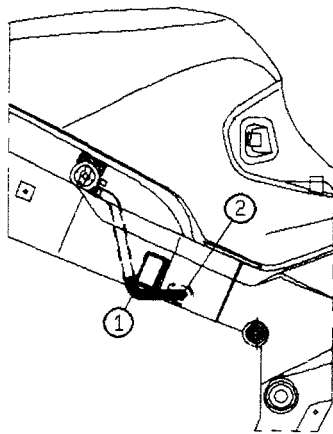

1. Fuel Pump Pipe
Route under cross pipe
2. Connect pipe so that while paint on pipe is top.

Cooling System

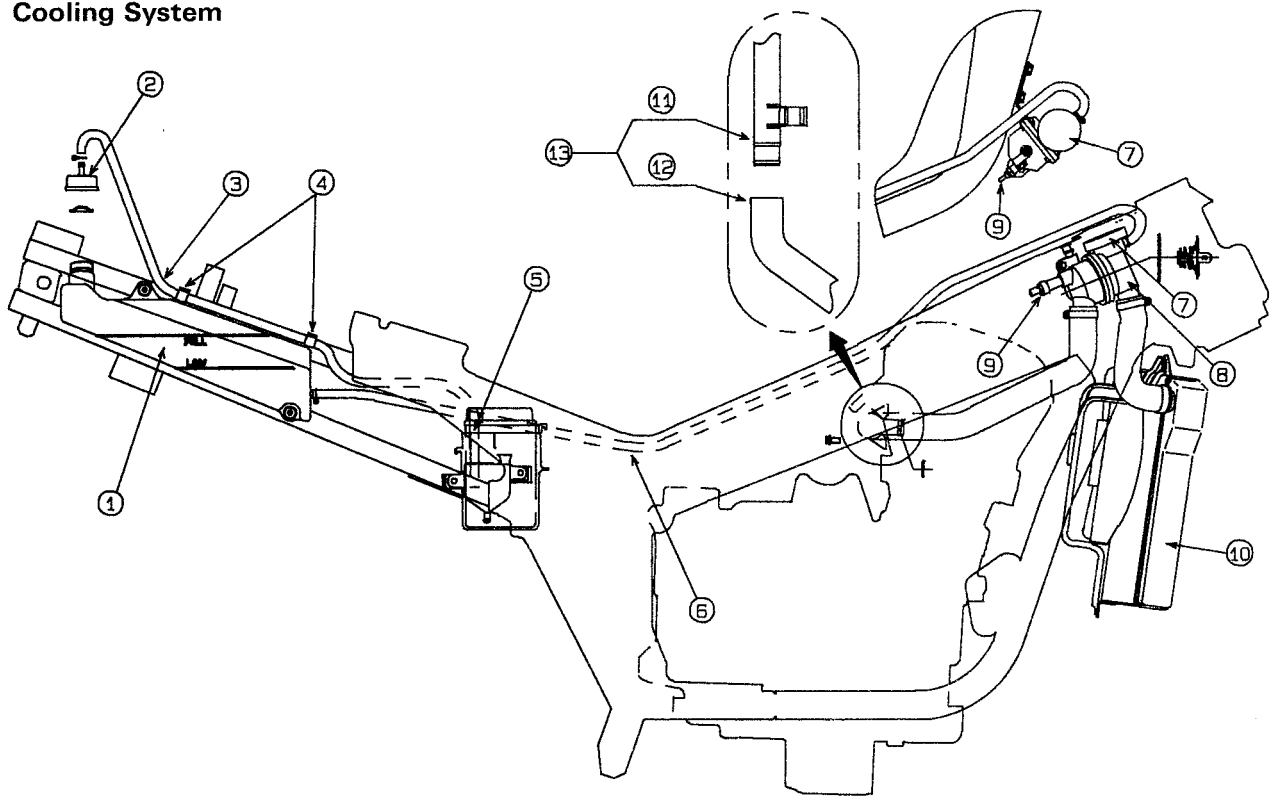

1. Reservoir Tank
2. Cap
3. Drain Hose
4. Clamps
5. Insert drain hose tip in breather case.
6. Reservoir Tank Hose
7. Radiator Cap
8. Thermostat Body
9. Water Temp. Switch
10. Radiator
11. Groove
12. White Color Painted
13. Insert hose so that white paint meets with groove.

Brake Hose

(1) Front Brake

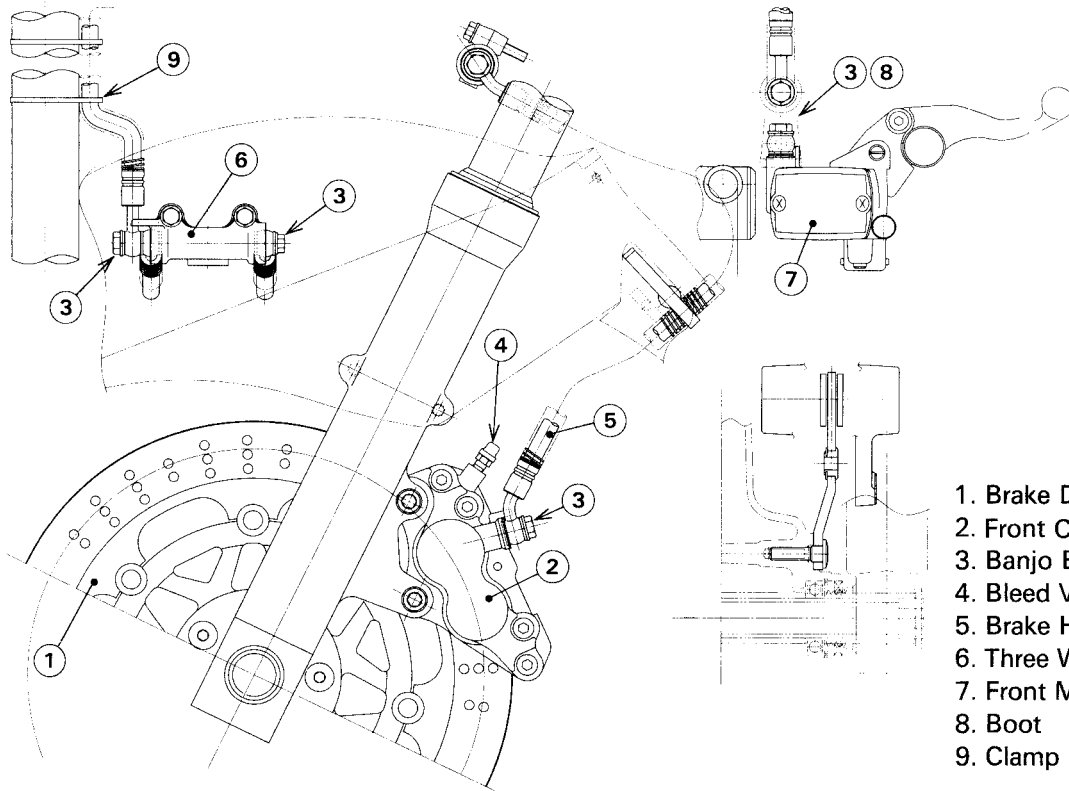

- 1. Brake Disc
- 2. Front Caliper
- 3. Banjo Bolts
- 4. Bleed Valve
- 5. Brake Hose
- 6. Three Way Joint
- 7. Front Master Cylinder
- 8. Boot
- 9. Clamp

(2) Rear Brake

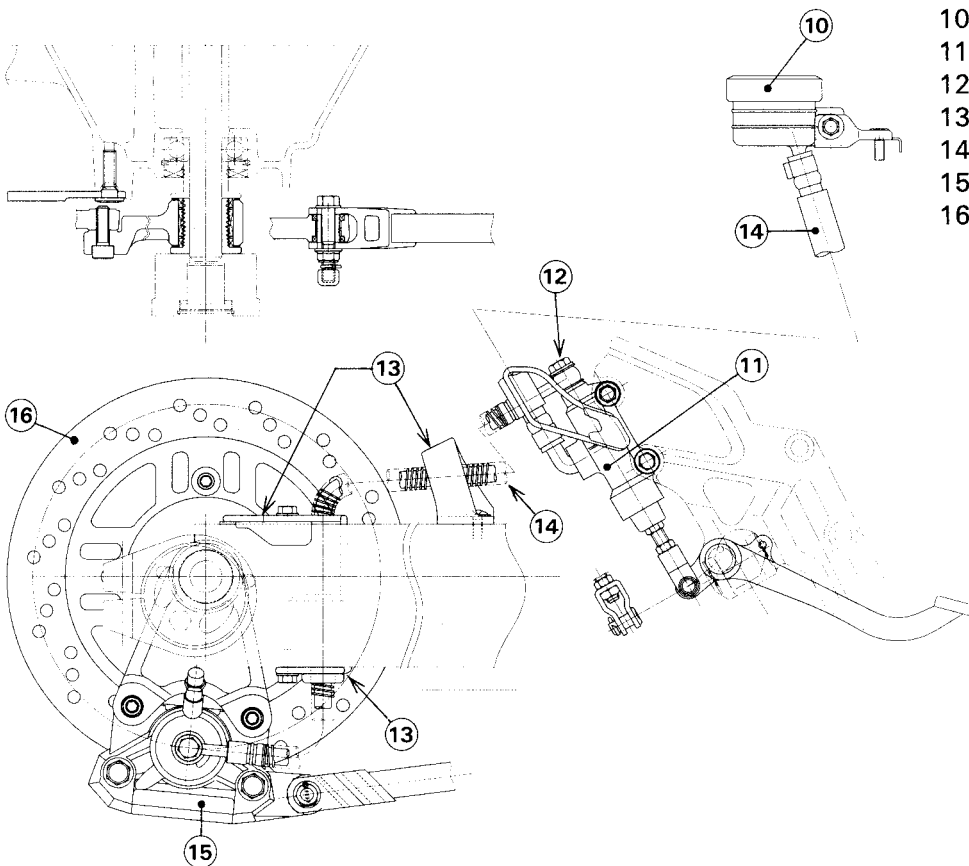

- 10. Rear Reservoir Tank
- 11. Rear Master Cylinder
- 12. Banjo Bolt
- 13. Clamp
- 14. Brake Hose
- 15. Rear Caliper
- 16. Brake Disc

Evaporative Emission Control System (California Model Only)

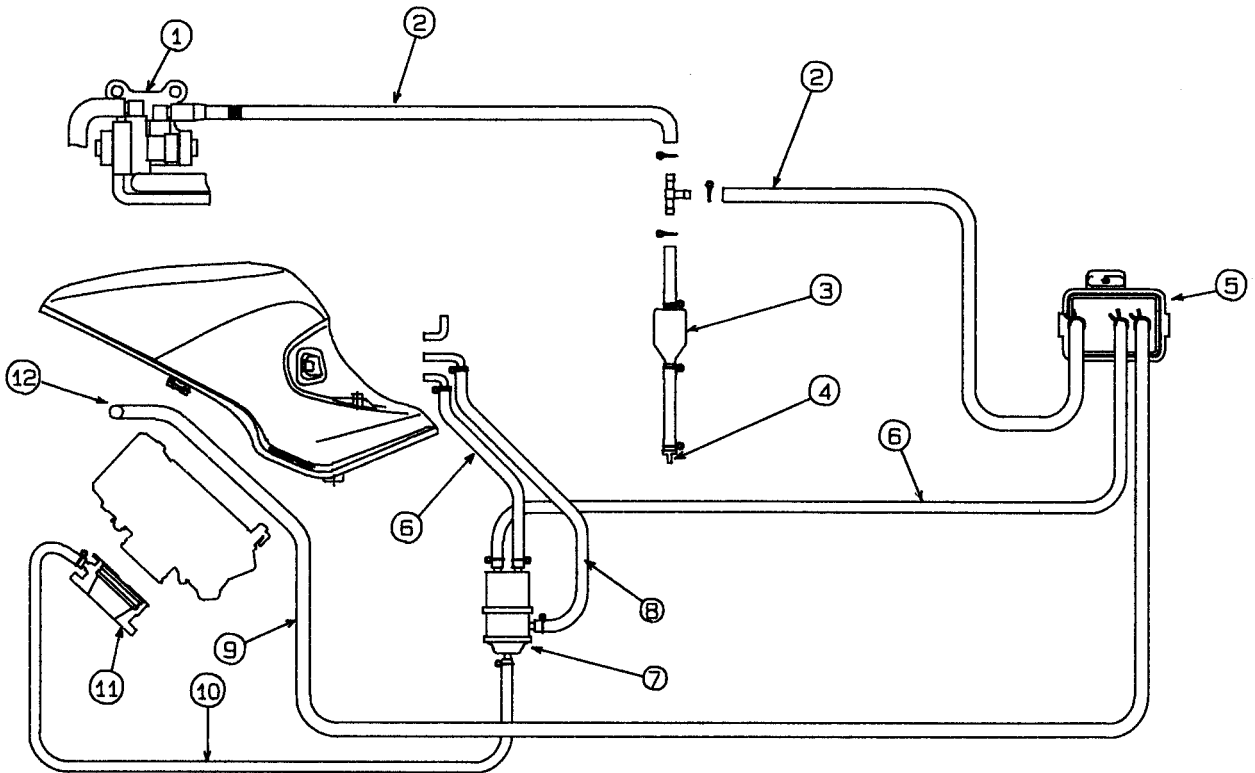

- 1. Vacuum Valve
- 2. Tube (Yellow)
- 3. Catch Tank
- 4. Plug
- 5. Canister
- 6. Tube (Blue)
- 7. Separator
- 8. Tube (Red)
- 9. Tube (Green)
- 10. Tube (White)

- 11. # 3 Carburetor Holder
- 12. To Vacuum Switch Valve Hose Connector

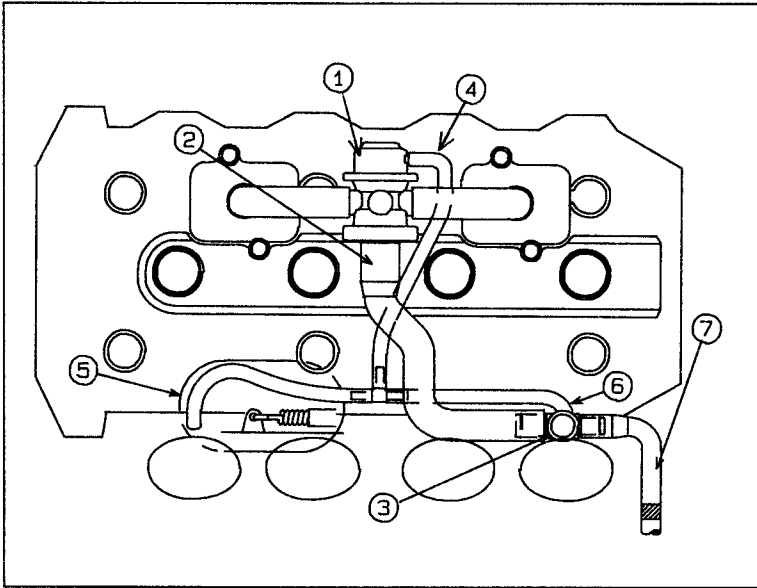

1. Vacuum Switch Valve
2. Vacuum Switch Valve Hose
3. To Bottom of Air Cleaner Housing
4. Vacuum Tube
5. To # 1 Carburetor Holder
6. # 4 Carburetor Holder
7. Tube (Green)
To Canister

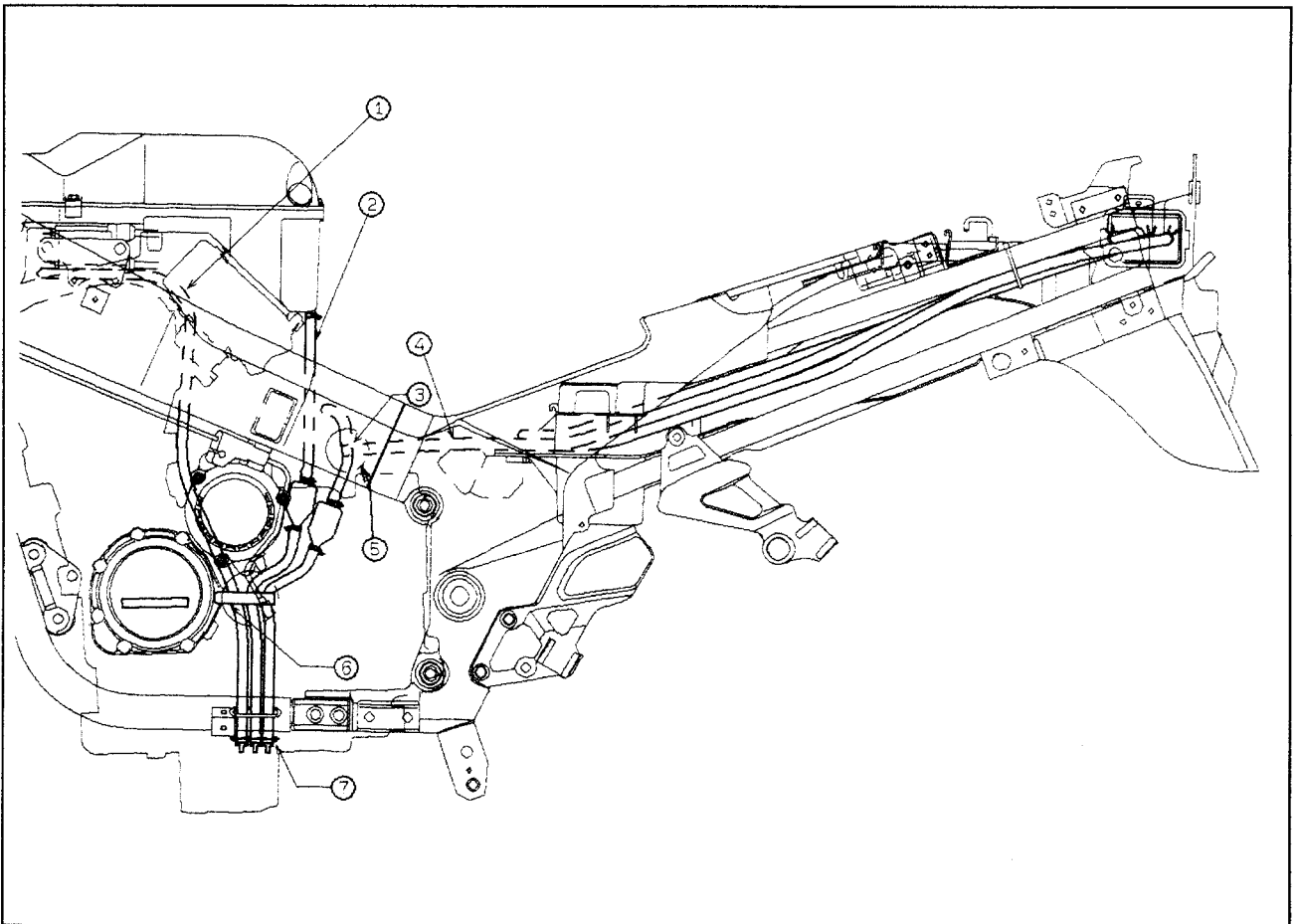

1. Air Cleaner Housing Front Left and Right Drain Tubes
Front of air Cleaner housing → Under ignition coil → Clamps (Left and Right).
2. Air Cleaner Housing Rear Drain Tube
3. Three Way Joint
4. Tube (Yellow)
5. This area should be lowest position in the yellow tube line.
6. Clamp
7. Clamp

1-28 GENERAL INFORMATION

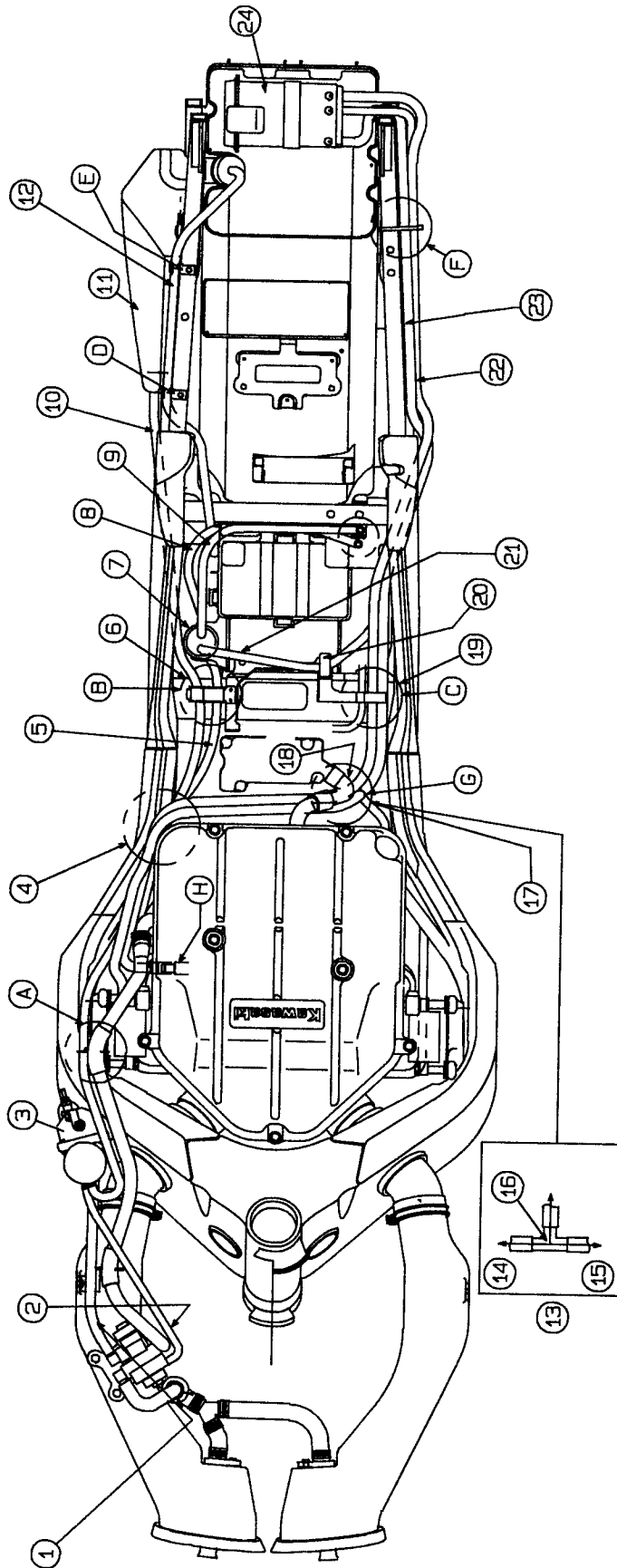

1. Tube (Yellow)
Three Way Joint at (G) → Front of crankcase breather hose → Under ignition coil → Under frame → Inside of radiator tank hose → Front of thermostat → Vacuum Valve.
2. Vacuum Hose
2 Carburetor Holder → Under ignition coil → Under frame → inside of radiator tank hose → Front of thermostat → Vacuum Valve.
3. Thermostat
4. Tubes (White, Green, Yellow) and Reservoir Tank Hose
Route these tubes and hose between frame and carburetor.
5. Tube (White)
3 Carburetor → Clamp at (B) → Separator
6. Clamp Following ones at (B)
Tube (White)
Reservoir Tank Hose
Main Wiring Harness
7. Separator
8. Tube (Red)
Separator → Back of battery case → Fuel tank.
9. Tube (Blue)
Separator → Back of battery case → Fuel tank.
10. Reservoir Tank Hose
Thermostat Cap → Clamp at (A) → Clamp at (B) → Reservoir Tank.
11. Reservoir Tank
12. Reservoir Tank Overflow Tube
Reservoir Tank → Clamp at (D) and (E) → Breather at side of battery case.
13. Three Way Joint
14. To Vacuum Valve
15. To Catch Tank
16. To Canister
17. Tubes (Yellow, Green)
Route these tubes at front of crankcase breather tube.
18. Engine Breather Tube
19. Clamp
Route tube (Yellow) at outside and tube (Green) at inside.
20. Clamp
21. Tube (Blue)
Separator → Clamp at (F) → canister.
22. Tube (Green)
Joint (H) → at front of crankcase breather tube → Clamp at (C) → Clamp at (F) → Canister.
23. Tube (Yellow)
Three Way Joint at (G) → Clamp at (C) → Clamp (F) → Canister.
24. Canister

1-30 GENERAL INFORMATION

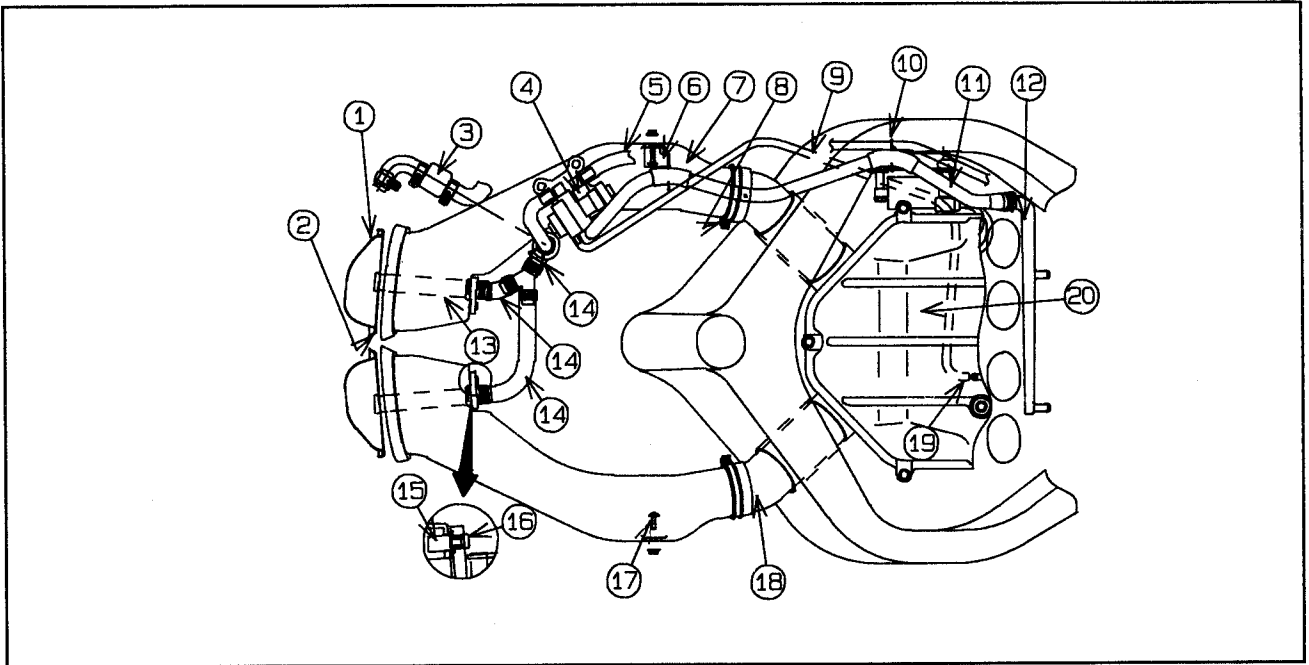

1. Screen
2. White Paint
ID mark for R.H.screen
3. Air Vent Filter
4. Vacuum Valve
5. Tube(Yellow)
6. Clamp
7. Air Dust
8. Clamp
9. Tube
To # 2 Carburetor Holder
10. Clamp

11. Reservoir Tank Hose
12. Pipe
To #1, 4 Carburetors
13. Pipe
14. Tube
15. Nut
16. Screw
17. Screw
18. Duct ID Mark
L or R mark should be up.
19. To # 2 Carburetor Holder
20. Air Cleaner Housing

Fuel System

Table of Contents

Exploded View	2-2	High Altitude Performance Adjustment (US model)	2-15
Specifications	2-5	Coolant Filter Cleaning (Ar, G, F, I, NL, UK Models)	2-15
Throttle Grip and Cables	2-6	Air Cleaner	2-16
Free Play Inspection	2-6	Housing Removal	2-16
Free Play Adjustment	2-6	Housing Installation Notes	2-16
Cable Installation Notes	2-6	Element Removal	2-16
Cable Lubrication	2-6	Element Installation	2-17
Choke Cable	2-7	Element Cleaning and Inspection	2-17
Free Play Inspection	2-7	Oil Draining	2-17
Free Play Adjustment	2-7	Air Cleaner Housing Installation	2-18
Installation Notes	2-7	Fuel Tank	2-19
Lubrication	2-7	Removal	2-19
Carburetors	2-8	Installation Notes	2-19
Idle Speed Inspection	2-8	Inspection	2-20
Idle Speed Adjustment	2-8	Cleaning	2-20
Synchronization Inspection	2-8	Fuel Tap Removal	2-20
Synchronization Adjustment	2-9	Fuel Tap Installation Notes	2-21
Service Fuel Level Inspection	2-9	Fuel Tap Inspection	2-21
Service Fuel Level Adjustment	2-10	Air Vent Filter Cleaning	2-21
Fuel System Cleanliness Inspection	2-11	Evaporative Emission Control System (California Model Only)	2-22
Removal	2-11	Parts Removal/Installation Notes	2-22
Installation Notes	2-12	Hose Inspection	2-22
Disassembly/Assembly Notes	2-12	Separator Inspection	2-22
Separation/Assembly Notes	2-13	Separator Operation Test	2-23
Cleaning	2-14	Canister Inspection	2-23
Inspection	2-14		

2-2 FUEL SYSTEM

Exploded View

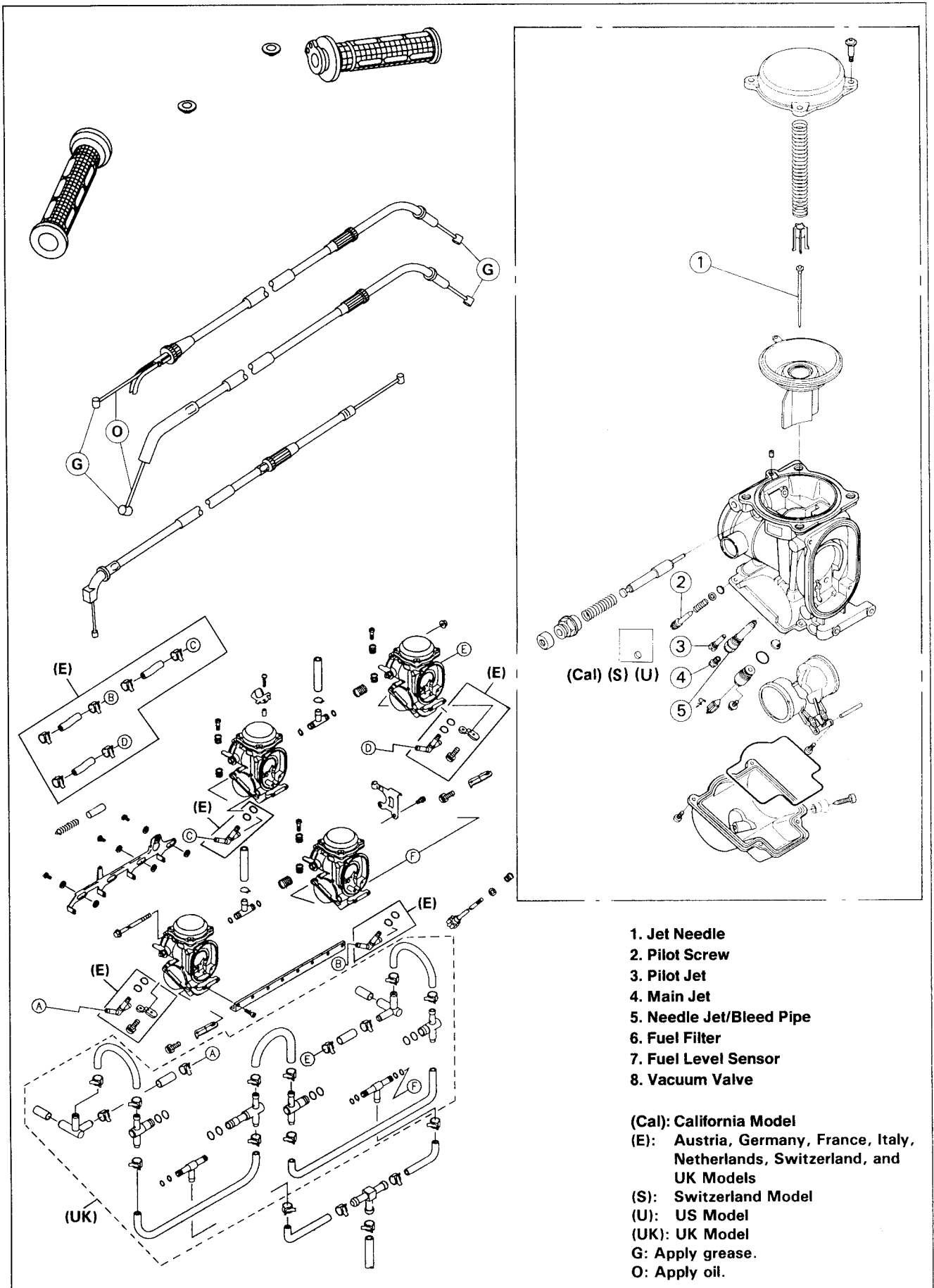

1. Jet Needle
2. Pilot Screw
3. Pilot Jet
4. Main Jet
5. Needle Jet/Bleed Pipe
6. Fuel Filter
7. Fuel Level Sensor
8. Vacuum Valve

(Cal): California Model
 (E): Austria, Germany, France, Italy, Netherlands, Switzerland, and UK Models
 (S): Switzerland Model
 (U): US Model
 (UK): UK Model
 G: Apply grease.
 O: Apply oil.

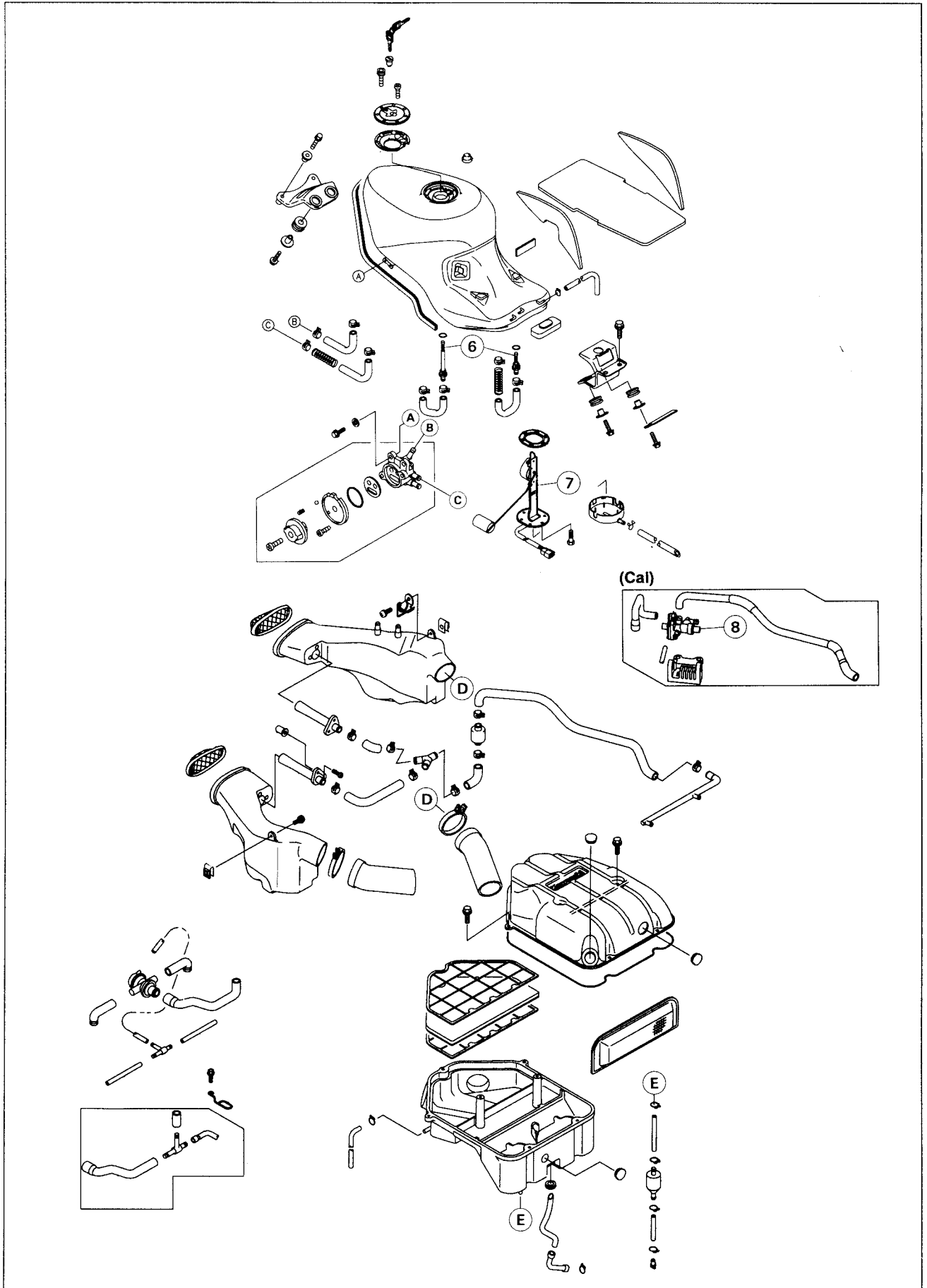

2-4 FUEL SYSTEM

- 9. Fuel Pump Relay
- 10. Fuel Filter
- 11. Fuel Pump
- 12. Separator
- 13. Canister
- 14. Hose (Yellow)
- 15. Hose (Yellow)
- 16. Hose (Green)
- 17. Hose (Red)
- 18. Hose (Blue)
- 19. Hose (Blue)
- 20. Hose (White)
- (Cal): California Model

(Cal)

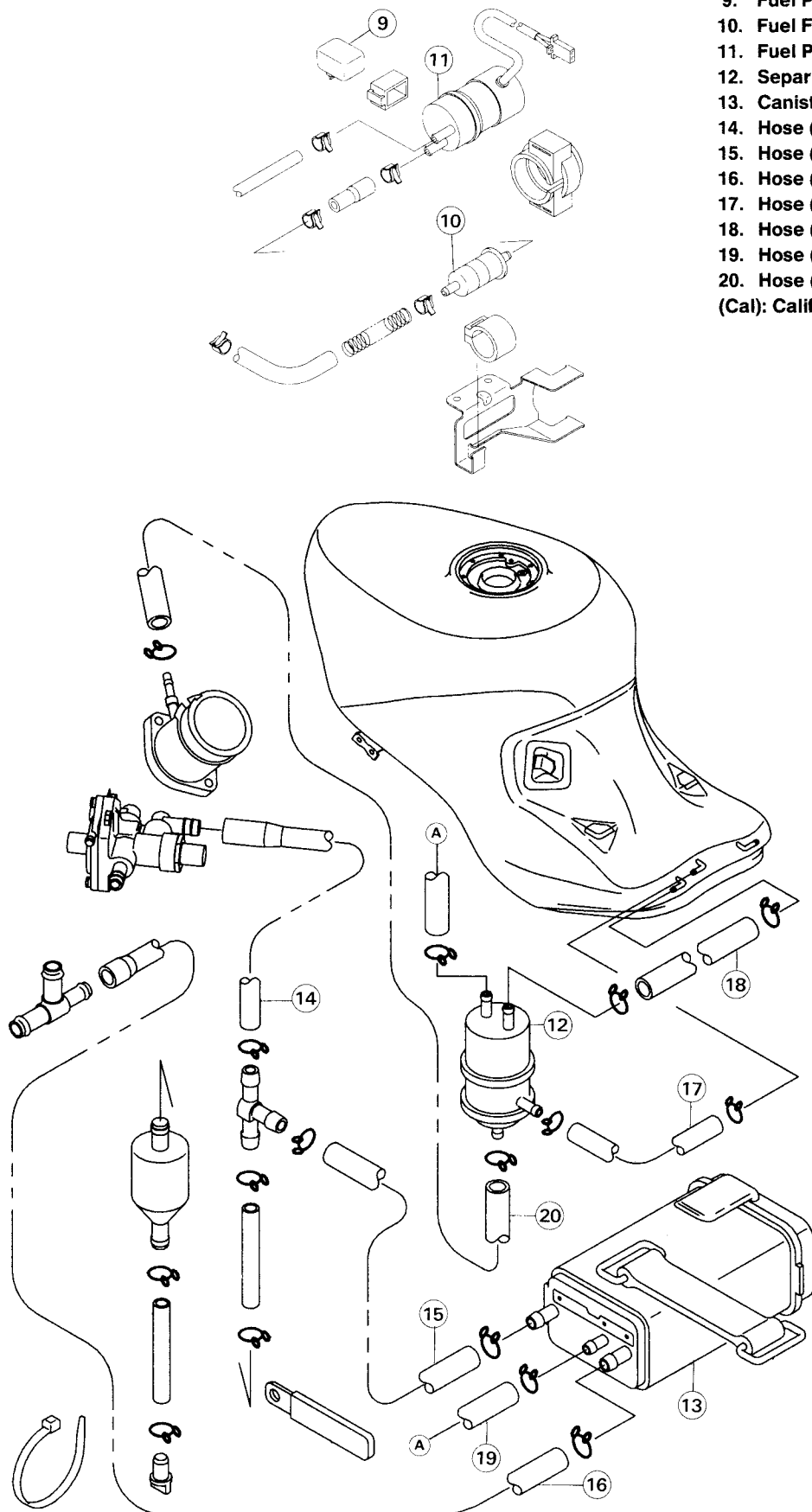

Specifications

Item	Standard
Throttle Grip and Cables: Throttle grip free play	2 ~ 3 mm
Choke Cable: Choke cable free play	2 ~ 3 mm
Carburetors: Make, type Main jet Main air jet Jet needle Pilot jet Pilot air jet Starter jet Pilot screw Service fuel level Float height Idle speed Synchronization vacuum	Keihin, CVKD40 # 1, # 4 : 160[158] # 2, # 3 : 158 [155] 70 N96X, (FR) # 1, # 4 N60U 38 [35] 120, (UK) 130 58 2.0 turns out, (Cal)(S) (U) – 4.5 ± 1 mm below the mark 13 ± 2 mm 950 ~ 1050 r/min (rpm) (Cal)(S) 1150 ~ 1250 r/min (rpm) Less than 2.7 kPa (2 cm Hg)

(Cal): California Model

(S): Switzerland Model

(U): U.S. Model

[] : High Altitude(US only)

Special Tool – Fuel Level Gauge: 57001-1017

Pilot Screw Adjuster, A: 57001-1239 *

Vacuum Gauge: 57001-1369

Pilot Screw Adjuster, C: 57001-1292 *

Pressure Cable Luber: k56019-021

(*): You may use whichever tool you like.

ZX1100-D3 (Refer to the above, nothing the following):

Item	Standard
Carburetors: Jet needle Pilot air jet Pilot screw	N96X, (E)#1,4 : N1VK #2,3 : N1VL 120 1¾ turns out, (G) (UK) 1⅝ turns out, (Cal) (S) (U) –

(E): Europe Models except for Austria, Sweden, and Switzerland Models

2-6 FUEL SYSTEM

Throttle Grip and Cables

Free Play Inspection

- Check the throttle grip free play [A].
- ★ If the free play is incorrect, adjust the throttle cable.

Throttle Grip Free Play

Standard: 2 ~ 3 mm

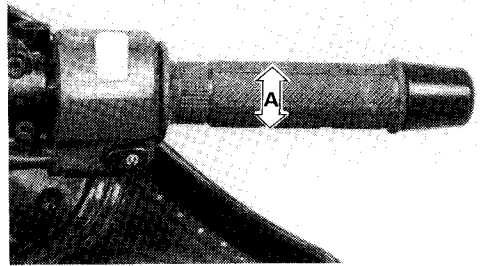

Free Play Adjustment

- Loosen the locknut [A].
- Turn the adjuster [B] until the proper amount of free play can be obtained.
- Tighten the locknut securely.
- ★ If the proper amount of free play cannot be obtained by using the adjuster only, use the adjuster in the middle part of the accelerator cable.

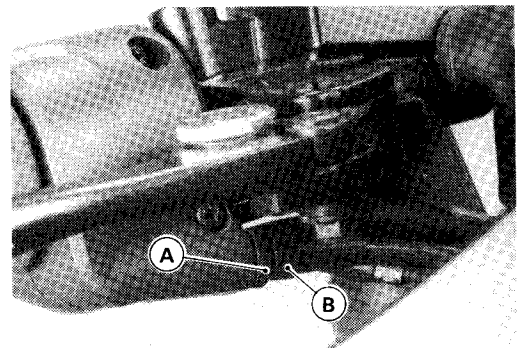

- Loosen the locknut and screw the adjuster at the upper end of the accelerator cable all the way in.
- Tighten the locknut securely.
- Remove the fuel tank and air cleaner housing (see Fuel Tank Removal).
- Loosen the locknut [A] at the middle part of the accelerator cable.
- Turn the adjuster [B] until the proper amount of throttle grip free play is obtained.
- Tighten the locknut securely.
- ★ If the proper amount of free play can not be obtained in the adjustable range of the adjuster, use the adjuster at the upper end of the accelerator cable again.

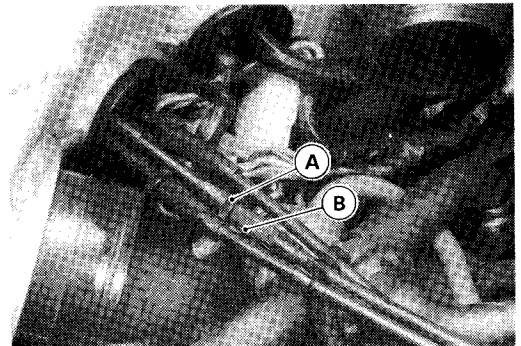

Cable Installation Notes

- Install the throttle cables in accordance with the Cable Routing section in the General Information chapter.
- Install the lower ends of the throttle cable in the cable bracket on the carburetor after installing the upper ends of the throttle cable in the grip.
- After installation, adjust each cable properly.

⚠ WARNING

Operation with incorrectly routed or improperly adjusted cables could result in an unsafe riding condition.

Cable Lubrication

Whenever the cable is removed, and in accordance with the Periodic Maintenance Chart (see General Information chapter), do the following.

- Apply a thin coating of grease to the cable lower ends.
- Lubricate the cable with a penetrating rust inhibitor.

Special Tool – Pressure Cable Luber: k56019-021 [A]

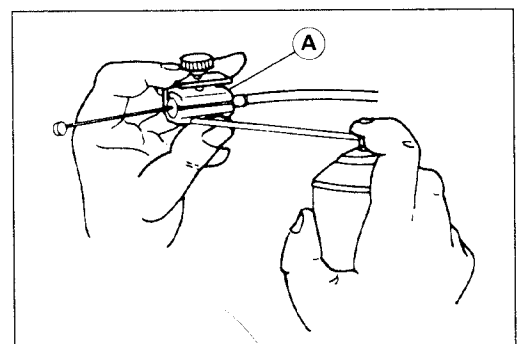

Choke Cable

Free Play Inspection

- Check that the choke inner cable slides smoothly by moving the choke lever [A] to the front and rear.
- ★ If there is any irregularity, check the choke cable play [B].

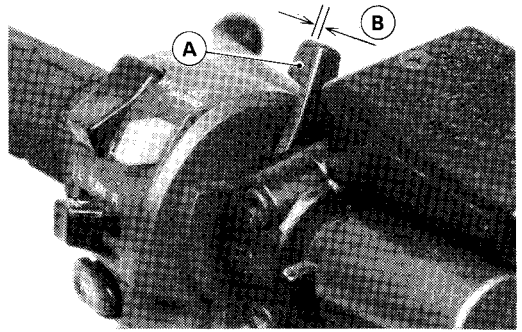

- Push the choke lever all the way to the front.
- Check choke cable free play.
- Determine the amount of choke cable play at the choke lever. Pull the choke lever until the starter plunger lever [A] at the carburetor touches the starter plunger [B]; the amount of choke lever lower end travel is the amount of choke cable play.
- ★ If the free play is incorrect, adjust the choke cable.

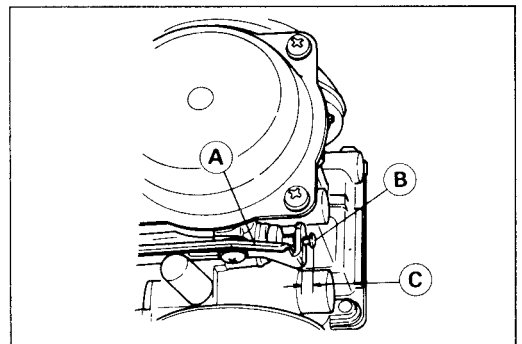

Choke Cable Free Play [C]
Standard: 2 ~ 3 mm

Free Play Adjustment

- Remove the fuel tank (see Fuel Tank Removal).
- Loosen the locknut [A], and turn the adjuster [B] until the cable has the proper amount of free play.
- Tighten the locknut securely.

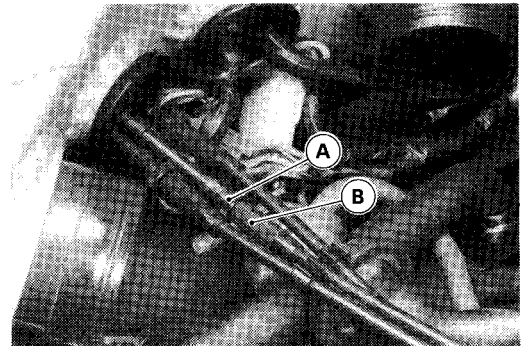

Installation Notes

- Install the choke cable in accordance with the Cable Routing section in the General Information chapter.
- After installation, adjust the cable properly.

▲WARNING

Operation with an incorrectly routed or improperly adjusted cable could result in an unsafe riding condition.

Lubrication

Whenever the choke cable is removed, lubricate the choke cable as follows:

- Apply a thin coating of grease to the cable upper end.
- Lubricate the cable with a penetrating rust inhibitor.

Special Tool – Pressure Cable Luber: k56019-021 [A]

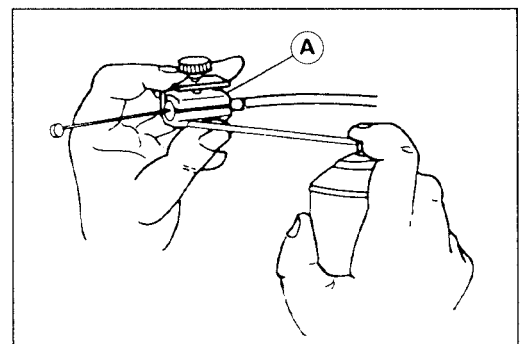

2-8 FUEL SYSTEM

Carburetors

Idle Speed Inspection

- Start the engine and warm it up thoroughly.
- With the engine idling, turn the handlebar to both sides.
- ★ If handlebar movement changes the idle speed, the throttle cables may be improperly adjusted or incorrectly routed, or damaged. Be sure to correct any of these conditions before riding (see Cable Routing section in the General Information chapter).

▲WARNING

Operation with improperly adjusted, incorrectly routed, or damaged cables could result in an unsafe riding condition.

- Check idle speed.
- ★ If the idle speed is out of the specified range, adjust it.

Idle Speed

Standard: 1,000 ± 50 r/min (rpm)
(California, Swiss Models) 1,200 ± 50 r/min (rpm)

Idle Speed Adjustment

- Start the engine and warm it up thoroughly.
- Turn the adjusting screw [A] until the idle speed is correct.
- Open and close the throttle a few times to make sure that the idle speed is within the specified range. Readjust if necessary.

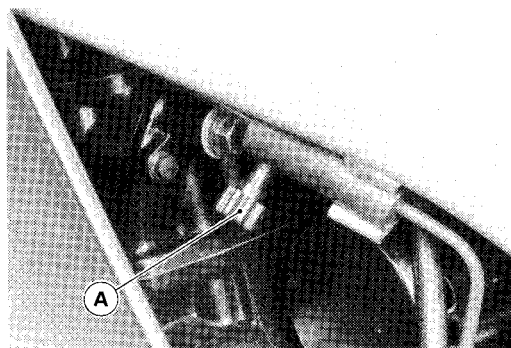

Synchronization Inspection

- Set the motorcycle on its center stand.
- Start the engine and warm it up thoroughly.
- Check idle speed.
- Remove the fuel tank. (see Fuel Tank Removal)
- Supply fuel to the carburetors with an auxiliary fuel tank.
- Remove the inner rear fairing.
- Remove the air cleaner housing.
- Pull the vacuum hoses off, and attach the vacuum gauge [A] to the fittings [B] on the carburetors.

Special Tool – Vacuum Gauge: 57001-1369

- Start the engine and let it idle to measure the carburetor intake vacuum.
- ★ If the vacuum is incorrect, adjust the synchronization.

Carburetor Synchronization Vacuum

Standard: Less than 2.7 kPa (2 cmHg) difference between any two carburetors.

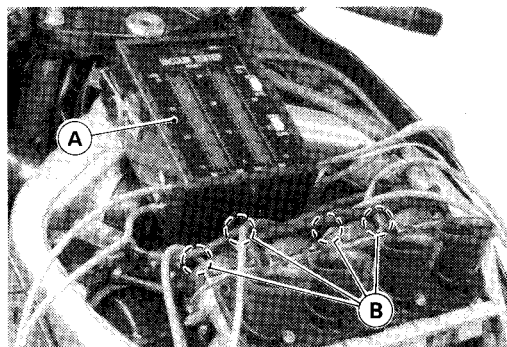

Synchronization Adjustment

- Turn the adjusting screw to synchronize the carburetors.
- First synchronize the left two and then the right two carburetors by means of the left and right adjusting screws [A, C]. Then synchronize the left two carburetors and the right two carburetors using the center adjusting screw [B].
- ★ If the carburetor synchronization cannot be obtained by using the adjusting screws, check for dirt or blockage, and then check the pilot screw settings.

**Special Tool – Pilot Screw Adjuster, A: 57001-1239 or
Pilot Screw Adjuster, C: 57001-1292**

- Check the carburetor synchronization again.

NOTE

- Do not turn the pilot screws carelessly during carburetor synchronization. You may cause poor running at low engine speed.
- Check idle speed.

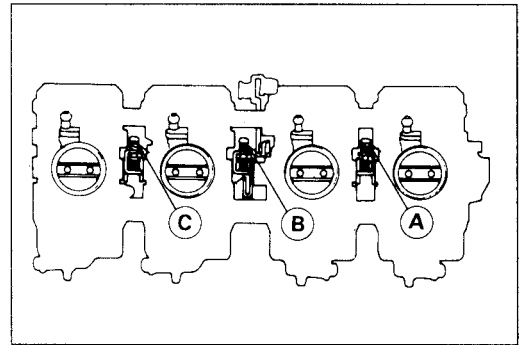

Service Fuel Level Inspection

⚠ WARNING

Gasoline is extremely flammable and can be explosive under certain conditions. Turn the ignition switch OFF. Do not smoke. Make sure the area is well-ventilated and free from any source of flame or sparks; this includes any appliance with a pilot light.

- Remove the carburetors, and hold them upright on a stand (see Carburetor Removal).
- Prepare an auxiliary fuel tank and connect the fuel hose to the carburetors.
- Prepare a fuel hose (6 mm in diameter and about 300 mm long).
- Connect the fuel level gauge [A] to the carburetor float bowl with the fuel hose.

Special Tool – Fuel Level Gauge: 57001-1017

- Hold the gauge [A] vertically against the side of the carburetor body so that the "zero" line [B] is several millimeters higher than the bottom edge of the carburetor body.
- Feed fuel to the carburetor, then turn the carburetor drain plug [C] out a few turns.
- Wait until the fuel level in the gauge settles.

NOTE

- Do not lower the "zero" line below the bottom edge of the carburetor body. If the gauge is lowered and then raised again, the fuel level measured shows somewhat higher than the actual fuel level. If the gauge is lowered too far, dump the fuel into a suitable container and start the procedure over again.

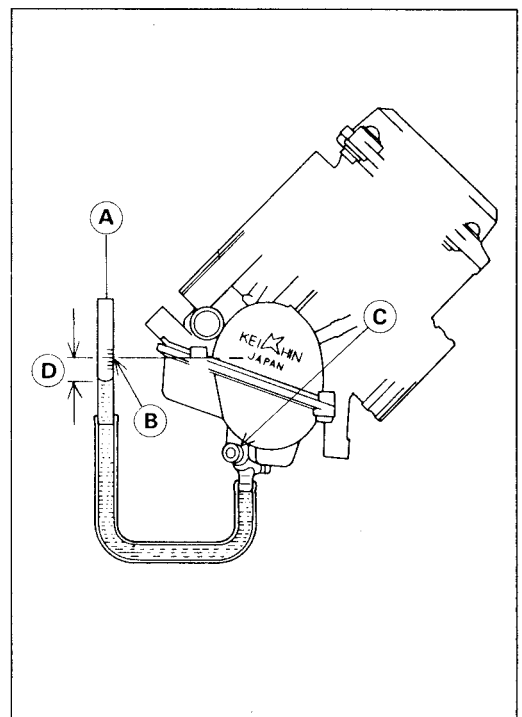

2-10 FUEL SYSTEM

- Read the fuel level [D] in the gauge and compare to the specification.
Screw in the carburetor drain plug.
- Stop feeding and remove the fuel level gauge.
- ★ If the fuel level is incorrect, adjust it (see Service Fuel Level Adjustment).

Service Fuel Level

Standard: 4.5 ± 1 mm below the mark

Service Fuel Level Adjustment

⚠ WARNING

Gasoline is extremely flammable and can be explosive under certain conditions. Turn the ignition switch OFF. Do not smoke. Make sure the area is well-ventilated and free from any source of flame or sparks; this includes any appliance with a pilot light.

- Remove the carburetor, and drain the fuel into a suitable container.
- Remove the float bowl.
- Remove the screw [A] and take out the float [B].
- Bend the tang [A] on the float arm very slightly to change the float height. Increasing the float height lowers the fuel level and decreasing the float height raises the fuel level.

Float Height

Standard: 13 ± 2 mm

NOTE

- Do not push the needle rod [A] in during the float height measurement [B].

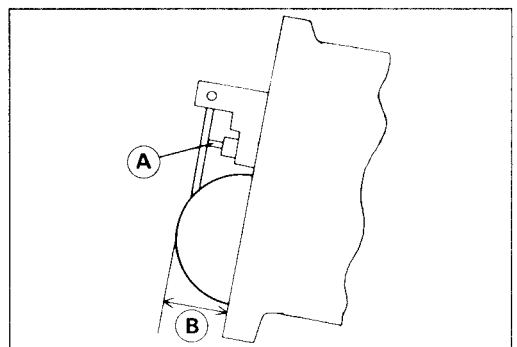
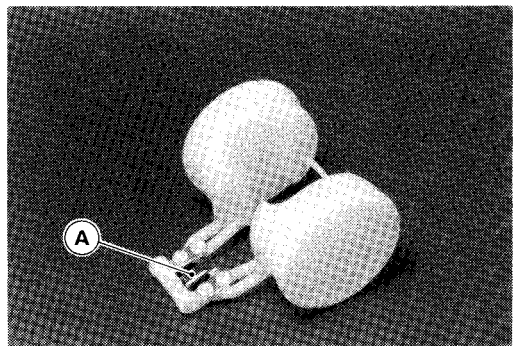
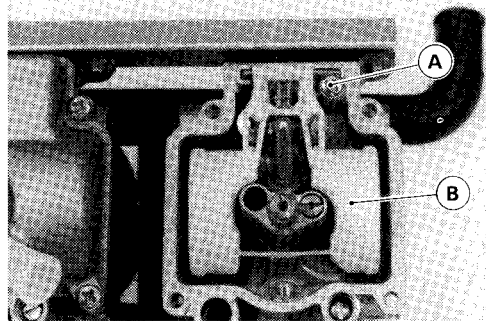

- Assemble the carburetor, and recheck the fuel level.
- ★ If the fuel level cannot be adjusted by this method, the float or the float valve is damaged.

*Fuel System Cleanliness Inspection***▲WARNING**

Gasoline is extremely flammable and can be explosive under certain conditions. Turn the ignition switch OFF. Do not smoke. Make sure the area is well-ventilated and free from any source of flame or sparks; this includes any appliance with a pilot light.

- Remove the following.
 - Seat
 - Fuel Tank
- Connect a suitable hose to the fitting at the bottom of each carburetor float bowl.
- Run the lower ends of the hoses into a suitable container.
- Turn the fuel tap to the PRI position.
- Turn out each drain plug a few turns and drain the float bowls.

**Special Tool – Pilot Screw Adjuster, A: 57001-1239 or
Pilot Screw Adjuster, C: 57001-1292 [A]**

- Check to see if water or dirt comes out.
- Tighten the drain plugs and turn the fuel tap to the ON position.
- ★ If any water or dirt appears during the above inspection, clean the fuel system (see Carburetor Cleaning and Fuel Tank Cleaning).

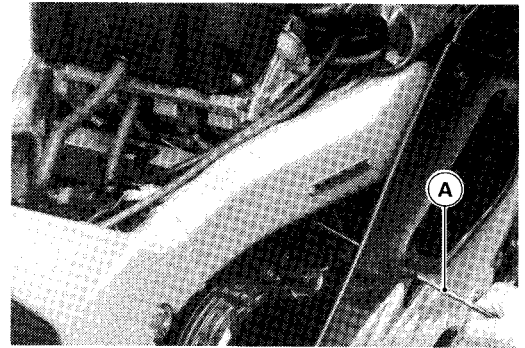
*Removal***▲WARNING**

Gasoline is extremely flammable and can be explosive under certain conditions. Turn the ignition switch OFF. Do not smoke. Make sure the area is well-ventilated and free from any source of flame or sparks; this includes any appliance with a pilot light.

- Remove:
 - Seat
 - Rear
 - Inner Tank
 - Fuel Tank
 - Air Cleaner Rear Housing
- Loosen the clamps, and pull the carburetors off the holders.
- Take out the carburetor assembly.
- Remove the throttle cable and choke cable lower ends.
- Stuff pieces of lint-free, clean cloth into the carburetor holders and the intake ducts to keep dirt out of the engine and air cleaner.

2-12 FUEL SYSTEM

Installation Notes

- Route the cables, harness, and hoses correctly (see General Information chapter).
- Tighten the clamps [A] for the carburetor holders.

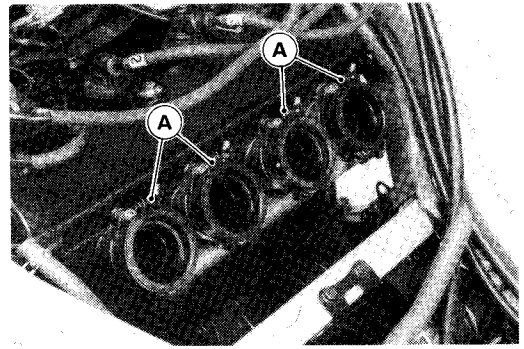

- Check fuel leakage from the carburetors.

▲WARNING

Fuel spilled from the carburetors is hazardous.

- Adjust the following items if necessary.
 - Idle Speed
 - Carburetor Synchronization
 - Throttle Cable
 - Choke Cable

Disassembly/Assembly Notes

▲WARNING

Gasoline is extremely flammable and can be explosive under certain conditions. Turn the ignition switch OFF. Do not smoke. Make sure the area is well-ventilated and free from any source of flame or sparks; this includes any appliance with a pilot light.

- For the US and Swiss models, remove the pilot screw plug as follows:
 - Punch a hole in the plug and pry there with an awl or other suitable tool.
- Turn in the pilot screw and count the number of turns until it seats fully but not tightly, and then remove the screw. This is to set the screw to its original position when assembling.
- After installing the upper chamber cover, check that the vacuum piston slides up and down smoothly without binding in the carburetor bore.

CAUTION

During carburetor disassembly, be careful not to damage the diaphragm. Never use a sharp edge to remove the diaphragm.

- Turn in the pilot screw [A] fully but not tightly, and then back it out the same number of turns counted during disassembly.
- For the US and Swiss models, install the pilot screw plug as follows:
 - Install a new plug [B] in the pilot screw hole, and apply a small amount of a bonding agent [C] to the circumference of the plug to fix the plug.

CAUTION

Do not apply too much bonding agent to the plug or the pilot screw itself may be fixed.

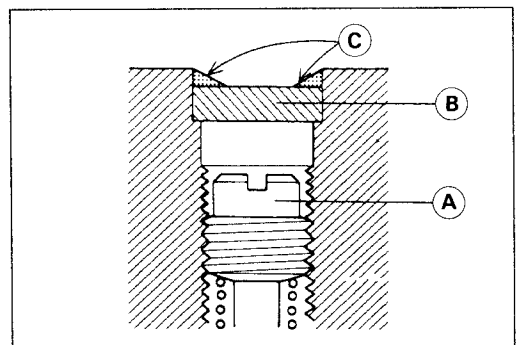

- Turn the carburetor body upside-down, and drop the needle jet [A] into place so that the smaller diameter end [B] of the jet goes in first.

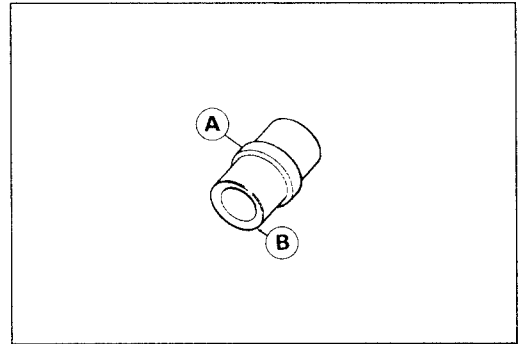

- Carefully screw in the needle jet holder. It will seat against the needle jet, pushing the end of the jet into the carburetor bore.

CAUTION

Do not force the needle jet holder [A] and main jet [B] or overtighten them. They could be damaged requiring replacement.

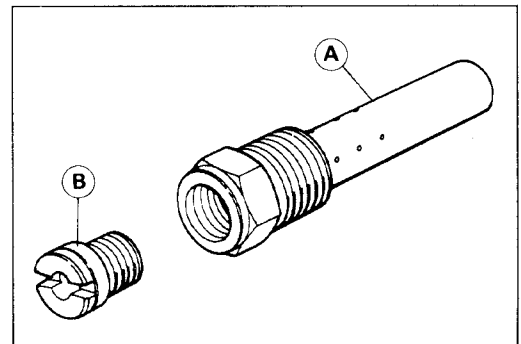

- Slip the needle through the hole in the center of the vacuum piston, and put the spring seat [A] on the top of the needle. Turn the seat so that it does not block the hole [B] at the bottom of the vacuum piston.

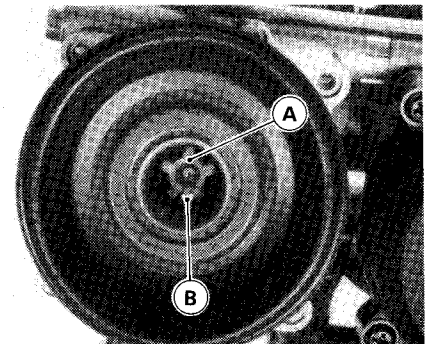

Separation/Assembly Notes

- Read the WARNING in the Carburetor Disassembly/Assembly Notes.
- The center lines of the carburetor bores must be parallel both horizontally and vertically. If they are not, loosen the mounting screws and align the carburetors on a flat surface. Retighten the mounting screws.
- After assembling the choke mechanism, check to see that the starter plunger lever slides right to left smoothly without abnormal friction.

CAUTION

Fuel mixture trouble could result if the starter does not seat properly in its rest position after the choke lever is returned.

- Visually synchronize the throttle (butterfly) valves.
- Check to see that all throttle valves open and close smoothly without binding when turning the pulley.
- Visually check the clearance [A] between the throttle valve and the carburetor bore in each carburetor.
- ★ If there is a difference between any two carburetors, turn the balance adjusting screw(s) [B] to obtain the same clearance.

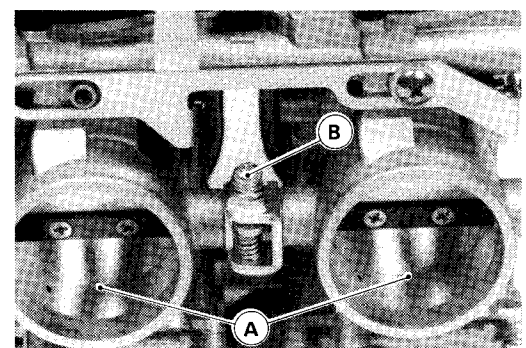

2-14 FUEL SYSTEM

Cleaning

▲WARNING

Clean the carburetors in a well-ventilated area, and take care that there is no spark or flame anywhere near the working area; this includes any appliance with a pilot light. Because of the danger of highly flammable liquids, do not use gasoline or low flash-point solvents to clean the carburetors.

CAUTION

Do not use compressed air on an assembled carburetor, or the floats may be crushed by the pressure, and the vacuum piston diaphragms may be damaged.

Remove as many rubber or plastic parts from the carburetor as possible before cleaning the carburetor with a cleaning solution. This will prevent damage to or deterioration of the parts.

The carburetor body has plastic parts that cannot be removed. Do not use a strong carburetor cleaning solution which could attack these parts; instead, use a mild high flash-point cleaning solution safe for plastic parts.

Do not use wire or any other hard instrument to clean carburetor parts, especially jets, as they may be damaged.

- Disassemble the carburetor.
- Immerse all the metal parts in a carburetor cleaning solution.
- Rinse the parts in water.
- When the parts are clean, dry them with compressed air.
- Blow through the air and fuel passages with compressed air.
- Assemble the carburetor.

Inspection

▲WARNING

Gasoline is extremely flammable and can be explosive under certain conditions. Turn the ignition switch OFF. Do not smoke. Make sure the area is well-ventilated and free from any source of flame or sparks; this includes any appliance with a pilot light.

- Remove the carburetors.
- Before disassembling the carburetors, check the fuel level (see Fuel Level Inspection).
- ★ If the fuel level is incorrect, inspect the rest of the carburetor before correcting it.
- Move the choke shaft left and release it to check that the starter plungers move smoothly and return by spring tension.
- ★ If the starter plungers do not work properly, replace the carburetors.
- Turn the throttle cable pulley to check that the throttle butterfly valves [A] move smoothly and return by spring tension.
- ★ If the throttle valves do not move smoothly, replace the carburetors.

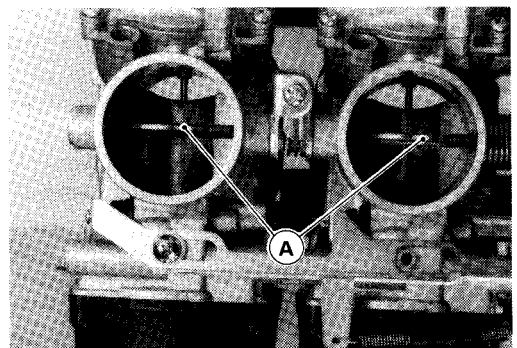

- Disassemble the carburetors.
- Clean the carburetors.
- Check that the O-rings on the float bowl and drain plug and the diaphragm on the vacuum piston are in good condition.
- ★ If any of the O-rings or diaphragms are not in good condition, replace them.
- Check the plastic tip [A] of the float valve needle [B]. It should be smooth, without any grooves, scratches, or tears.
- ★ If the plastic tip is damaged [C], replace the needle.
- Push in the rod [D] in the other end of the float valve needle and then replace it.
- ★ If it does not spring out, replace the needle.
- Check the tapered portion [A] of the pilot screw [B] for wear or damage.
- ★ If the pilot screw is worn or damaged on the tapered portion, it will prevent the engine from idling smoothly. Replace it.

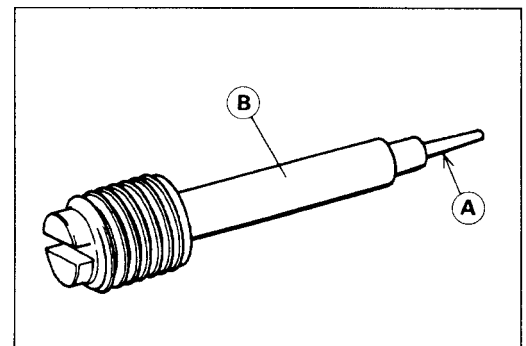
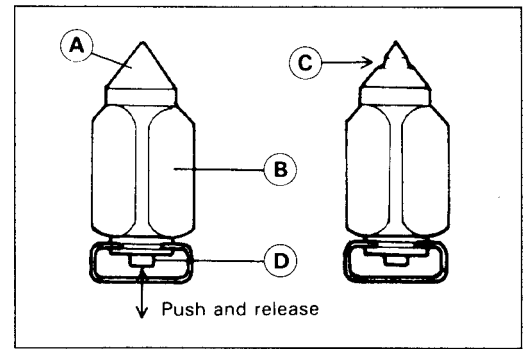

- Check that the vacuum piston [A] moves smoothly in the carburetor body. The surface of the piston must not be excessively worn.
- ★ If the vacuum piston does not move smoothly, or if it is very loose in carburetor body, replace the carburetor.

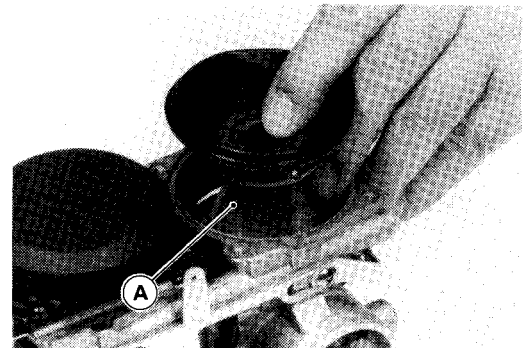

High Altitude Performance Adjustment (US model)

- To improve the EMISSION CONTROL PERFORMANCE of vehicle operated above **4000 feet**, Kawasaki recommends the following Environmental Protection Agency (EPA) approved modification.
- Change the main jet and pilot jet for high altitude use.

High Altitude Carburetor Specifications

- Pilot Jet:** # 35 (92064-1101)
- Main Jet:** # 158 (# 1,4 cyl. 92063-1344)
155 (# 2,3 cyl. 92063-1332)

Coolant Filter Cleaning (Ar, G, F, I, NL, S, UK Models)

Before winter season starts, clean the filter of carburetor system.

- Remove the fuel tank (see Fuel Tank Removal).
- Drain the coolant (see Cooling System chapter).
- Remove the filter [A] from the cooling hoses [B] of carburetor system.
- Blow off dirt and sediment on the filter with compressed air.

(Ar, G, F, I, NL, S, UK Models):

Austria, Germany, France, Italy, Netherlands,
Switzerland, and UK Models

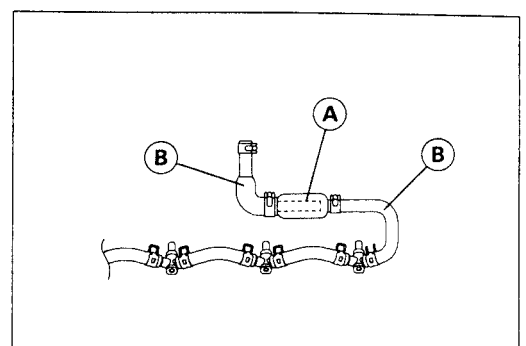

2-16 FUEL SYSTEM

Air Cleaner

Housing Removal

- Remove:
 - Seat
 - Fuel Tank
 - Inner Rear Fairing
- Remove the mounting bolt [A], and take off the upper housing [B].

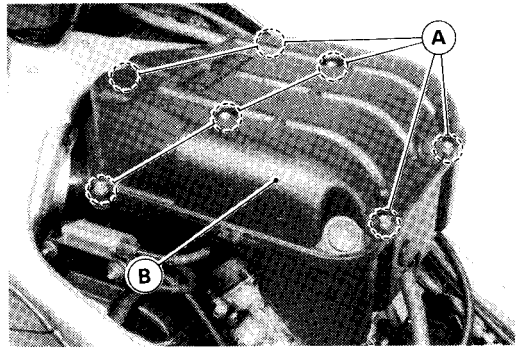

- Remove:
 - Air cleaner Screen [A]
 - Air Cleaner Element [B]
 - Air Cleaner Drain Hoses
 - Engine Breather Hose
 - Air Duct

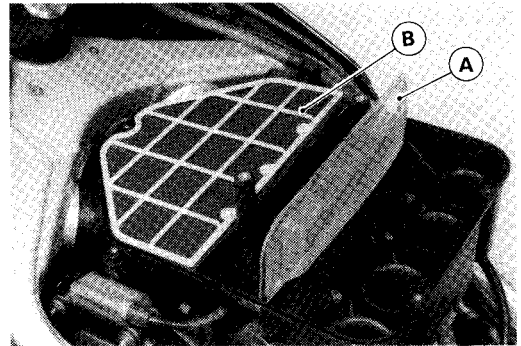

- Remove the lower housing mounting bolts [A], and take off the front housing [B] from the carburetor.

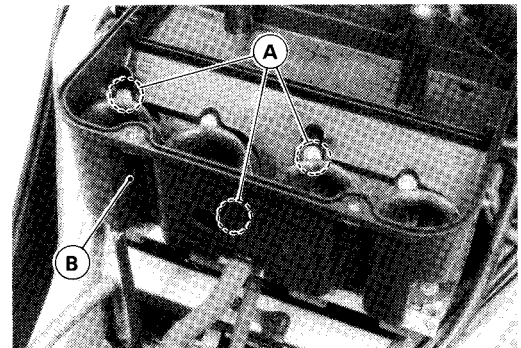

Housing Installation Notes

- Connect the front and rear drain tubes to the lower housing (see General Information chapter).
- Fit the O-ring [A] of the rear housing in place.
- Install the rubber plugs [B] in place.

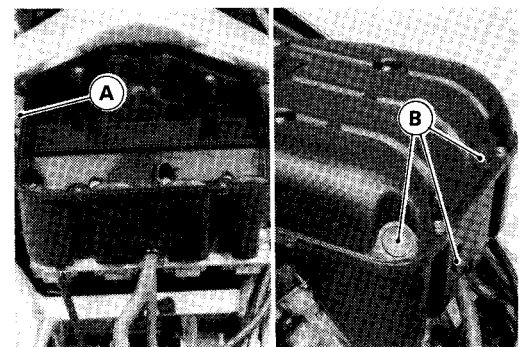

Element Removal

- Remove:
 - Air Cleaner Upper Housing Mounting Bolts
- Remove the upper housing.
- Take out the element.

Element Installation

- Element installation is the reverse of removal.
- Install the screen [A] so that the protrusion side faces the carburetor.

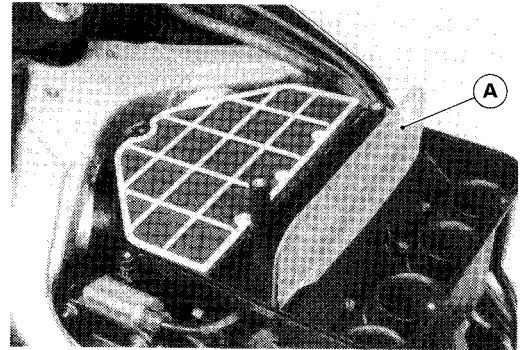

Element Cleaning and Inspection

NOTE

- In dusty areas, the element should be cleaned more frequently than the recommended interval.
- After riding through rain or on muddy roads, the element should be cleaned immediately.
- Since repeated cleaning opens the pores of the foam in the element, replace it with a new one in accordance with the Periodic Maintenance Chart. Also, if there is a break in the element material or any other damage to the element, replace the element with a new one.

▲WARNING

Clean the element in a well-ventilated area, and make sure that there are no sparks or flame anywhere near the working area. Because of the danger of highly flammable liquids, do not use gasoline or a low flash-point solvent to clean the element.

- Take out the air cleaner element [A] from the lower air cleaner housing.
- Clean the element in a bath of high flash-point solvent, and then dry it with compressed air or by shaking it.
- After cleaning, saturate a clean, lint-free towel with SE class SAE 30 oil and apply the oil to the element by tapping the element outside with the towel.
- Visually check the element for tears or breaks.
- ★ If the element has any tears or breaks, replace the element.
- Replace the element according to the Periodic Maintenance Chart (see General Information chapter).

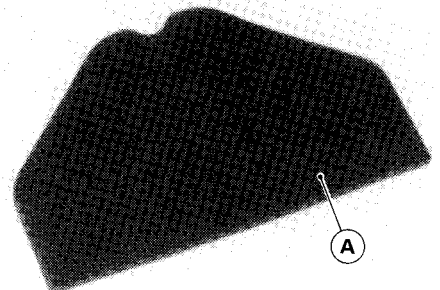

Oil Draining

A drain hose [A] is connected to the bottom of the air cleaner housing, to drain oil accumulated at the bottom of the housing.

- Visually check the drain hose if the oil accumulates in the hose.
- ★ If any water or oil accumulates in the tank, drain it by taking off the drain plug [B] at the lower end of the drain hose.

▲WARNING

Be sure to reinstall the plug in the drain hose after draining. Oil on tires will make them slippery and can cause an accident and injury.

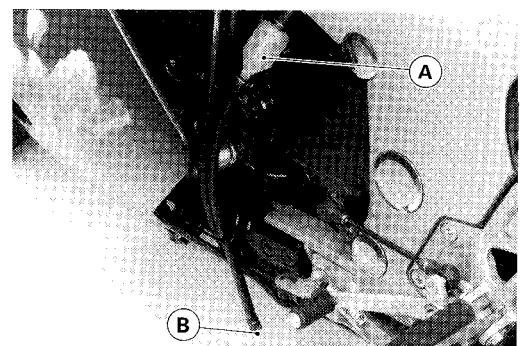

2-18 FUEL SYSTEM

Air Cleaner Housing Installation

- Be sure to fit the engine breather hose and draining hoses into the air cleaner housing (see Cable Routing in the General Information Chapter).

Fuel Tank

Removal

⚠ WARNING

Gasoline is extremely flammable and can be explosive under certain conditions. Turn the ignition switch OFF. Do not smoke. Make sure the area is well-ventilated and free from any source of flame or sparks; this includes any appliance with a pilot light.

CAUTION

For California model, if gasoline, solvent, water or any other liquid enters the canister, the canister's vapor absorbing capacity is greatly reduced. If the canister does become contaminated, replace it with a new one.

- Remove:
 - Seat
- Turn the fuel tap to the ON or RES position.
- Pull the fuel hose [A] off the tap.

NOTE

○ Do not pull other two fuel hoses [B], [C] off the tank, other wise fuel will flow out.

- Remove the fuel tank mounting bolts [A].
- Disconnect the fuel level sensor lead connector.
- Remove the fuel tank.

- Drain the fuel tank.
 - Place a suitable container under the fuel tank.
 - Turn the fuel tap to the PRI position to drain the fuel into the container.
- The fuel level sensor [A] is installed at the bottom of the fuel tank, if it is replaced with new one, remove it.

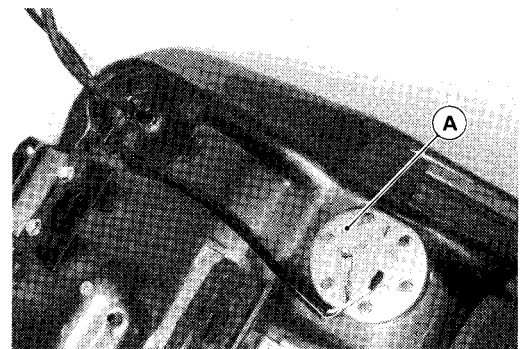
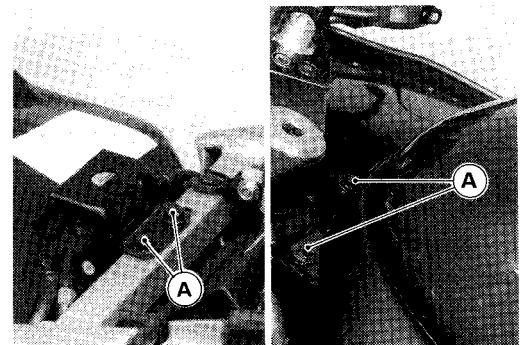
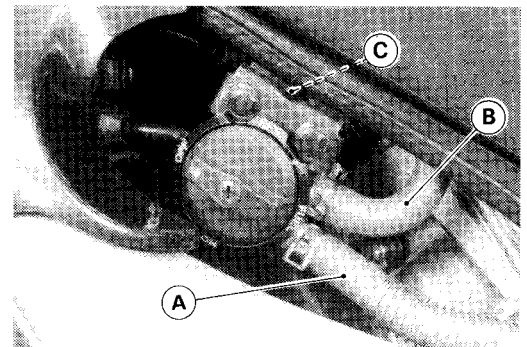

Installation Notes

- Read the above WARNING.
- Route the hoses and leads correctly (see General Information chapter).
- Be sure the hoses are clamped securely to prevent leaks.

2-20 FUEL SYSTEM

Inspection

- Visually inspect the gaskets on the tank and cap for any damage.
- ★ Replace the gaskets if they are damaged.
- Remove the hose(s) from the fuel tank, and open the tank cap.
- Check to see if the breather and water drain pipes (also the fuel return pipe for the California model) in the tank are not clogged. Check the tank cap breather also.
- ★ If they are clogged, remove the tank and drain it, and then blow the breather free with compressed air.

CAUTION

Do not apply compressed air to the air vent holes [A] on the tank cap. This could cause damage and clogging of the labyrinth in the cap.

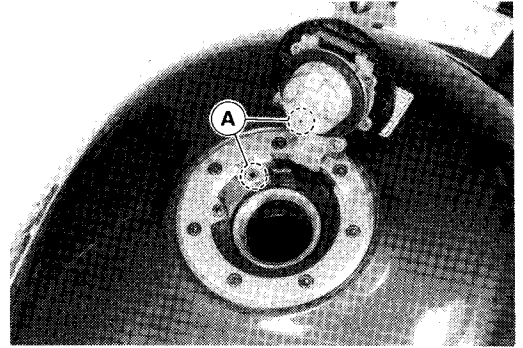

Cleaning

▲WARNING

Clean the tank in a well-ventilated area, and take care that there are no sparks or flame anywhere near the working area. Because of the danger of highly flammable liquids, do not use gasoline or low flash point solvents to clean the tank.

- Remove the fuel tank and drain it.
- Pour some high flash-point solvent into the fuel tank and shake the tank to remove dirt and fuel deposits.
- Pour the solvent out of the tank.
- Remove the fuel tap from the tank (see Fuel Tap Removal).
- Clean the fuel tap filter screens in a high flash point solvent.
- Pour high flash point solvent through the tap in all lever positions.
- Dry the tank and tap with compressed air.
- Install the tap in the tank.
- Install the fuel tank.

Fuel Tap Removal

- Remove the fuel tank and drain it.
- Remove the mounting bolts [A] with nylon flat washers and take out the fuel tap.

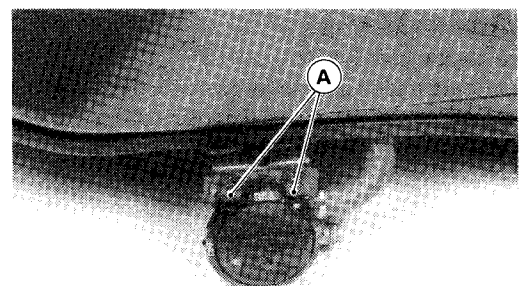

Fuel Tap Installation Notes

- Be sure the O-ring is in good condition to prevent leaks.
- Be sure to clamp the fuel hoses to the tap to prevent leaks.
- Be sure the nylon washers are in good condition to prevent leaks.
- Do not use steel washers in place of the nylon washers, because they will not seal the bolts properly and fuel will leak.

Fuel Tap Inspection

- Remove the fuel tap.
- Check the fuel tap filter screens [A] for any breaks or deterioration.

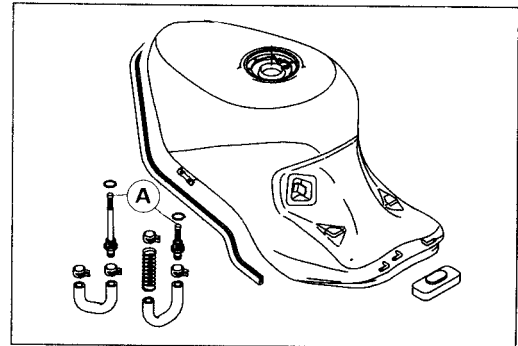

- ★ If the fuel tap screens have any breaks or are deteriorated, they may allow dirt to reach the carburetor, causing poor running. Replace the fuel tap.
- ★ If the fuel tap leaks, or allows fuel to flow when it is at ON or RES position without engine running, replace the damaged gasket [A] or O-ring [B].

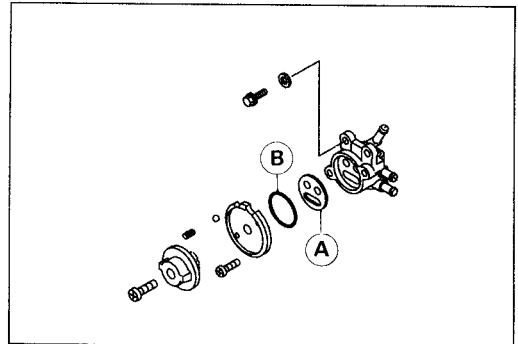

Air Vent Filter Cleaning

Air vent filter[A] is located at the front of the air switch valve.

- Remove the rear and front inner fairing.
- Clean the filter by directing a stream of compressed air from the clean side to the dirty side[B].

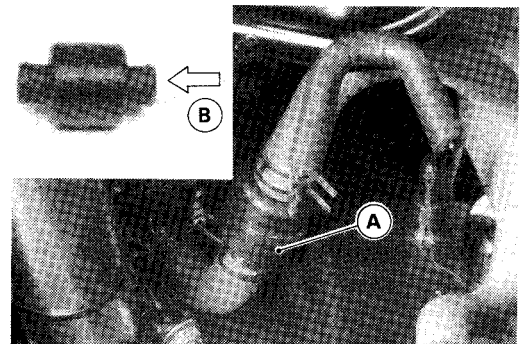

2-22 FUEL SYSTEM

Evaporative Emission Control System (California Model Only)

The Evaporative Emission Control System routes fuel vapors from the fuel system into the running engine or stores the vapors in a canister when the engine is stopped. Although no adjustments are required, a thorough visual inspection must be made at the intervals specified by the Periodic Maintenance Chart.

Parts Removal/Installation Notes

▲WARNING

Gasoline is extremely flammable and can be explosive under certain conditions. Turn the ignition switch OFF. Do not smoke. Make sure the area is well-ventilated and free from any source of flame or sparks; this includes any appliance with a pilot light.

CAUTION

If gasoline, solvent, water or any other liquid enters the canister, the canister's vapor absorbing capacity is greatly reduced. If the canister does become contaminated, replace it with a new one.

- To prevent the gasoline from flowing into or out of the canister, hold the separator perpendicular to the ground.
- Connect the hoses according to the diagram of the system. Make sure they do not get pinched or kinked.

1. Vacuum Valve
2. Tube (Yellow)
3. Catch Tank
4. Plug
5. Canister
6. Tube (Blue)
7. Separator
8. Tube (Red)
9. Tube (Green)
10. Tube (White)
11. # 3 Carburetor Holder
12. To Vacuum Switch Valve Hose Connector

Hose Inspection

- Check that the hoses are securely connected.
- Replace any kinked, deteriorated or damaged hoses.

Separator Inspection

- Disconnect the hoses from the liquid/vapor separator, and remove the separator from the motorcycle.
- Visually inspect the separator for cracks and other damage.
- ★ If the separator has any cracks or is badly damaged, replace it with a new one.

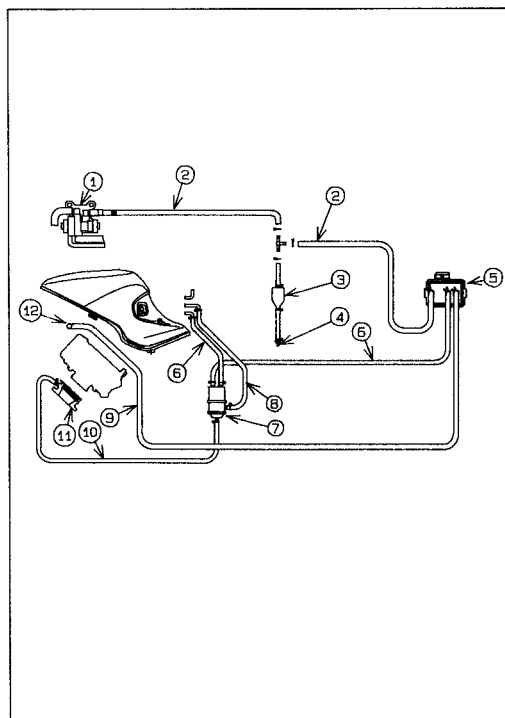

Separator Operation Test

▲WARNING

Gasoline is extremely flammable and can be explosive under certain conditions. Turn the ignition switch OFF. Do not smoke. Make sure the area is well-ventilated and free from any source of flame or sparks; this includes any appliance with a pilot light.

- Connect the hoses to the separator, and install the separator on the motorcycle.
- Disconnect the breather hose from the separator, and inject about 20 mL of gasoline into the separator through the hose fitting.
- Disconnect the fuel return hose from the fuel tank.
- Run the open end of the return hose into the container level with the tank top.
- Start the engine, and let it idle.
- ★ If the gasoline in the separator comes out of the hose, the separator works well. If it does not, replace the separator with a new one.

Canister Inspection

- Remove the canister, and disconnect the hoses from the canister.
- Visually inspect the canister for cracks and other damage.
- ★ If the canister has any cracks or bad damage, replace it with a new one.

NOTE

- *The canister is designed to work well through the motorcycle's life without any maintenance if it is used under normal conditions.*

Cooling System

Table of Contents

Exploded View	3-2
Specifications	3-3
Coolant	3-4
Coolant Level Inspection	3-4
Coolant Draining	3-4
Coolant Filling	3-5
Pressure Testing	3-6
Water Pump	3-7
Removal	3-7
Installation	3-7
Water Pump Inspection	3-7
Radiator and Radiator Fan	3-8
Removal	3-8
Radiator Inspection	3-9
Radiator Cap Inspection	3-9
Thermostat	3-11
Removal	3-11
Installation	3-11
Inspection	3-11
Thermostat Fan Switch and Water Temperature Sensor	3-12

3-2 COOLING SYSTEM

Exploded View

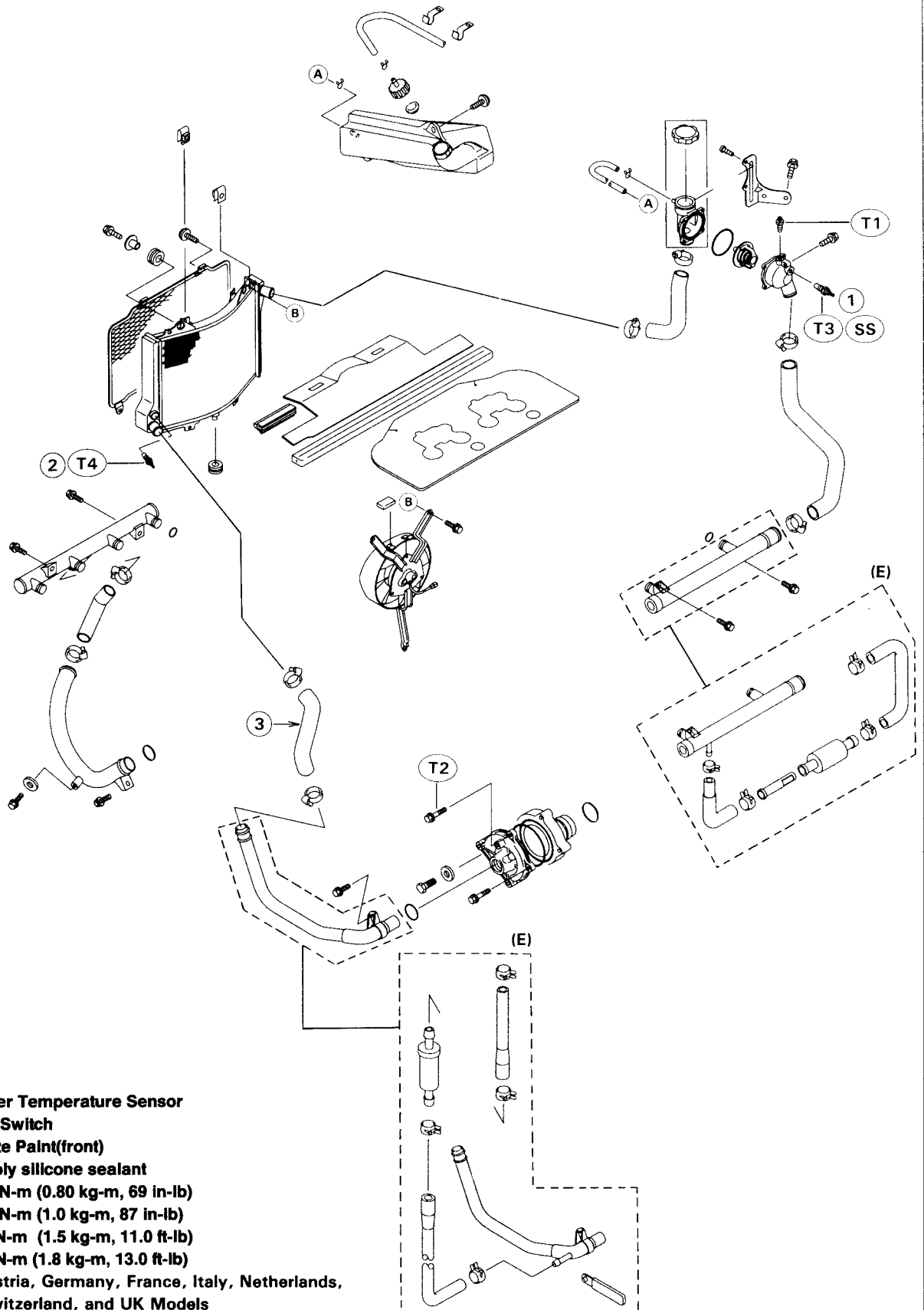

1. Water Temperature Sensor

2. Fan Switch

3. White Paint(front)

SS: Apply silicone sealant

T1 : 7.8 N-m (0.80 kg-m, 69 in-lb)

T2 : 9.8 N-m (1.0 kg-m, 87 in-lb)

T3 : 15 N-m (1.5 kg-m, 11.0 ft-lb)

T4 : 18 N-m (1.8 kg-m, 13.0 ft-lb)

(E): Austria, Germany, France, Italy, Netherlands,
Switzerland, and UK Models

Specifications

Item	Standard
Coolant: Type Mixed ratio Freezing point Total amount	Permanent type of antifreeze (soft water and ethylene glycaol plus corrosion and rust inhibitor chemicals for aluminum engines and radiators) Soft water 50%, coolant 50% -35°C(-31°F) 2.5L
Radiator cap relief pressure: Radiator cap relief pressure	93 ~ 123 kPa(0.95 ~ 1.25kg/ cm ² , 14 ~ 18 psi)
Thermostat: Valve opening temperature Valve full opening lift	80 ~ 84°C(176 ~ 183 °F) more than 8 mm @95°C(203 °F)

Sealant – Kawasaki Bond (Silicone Sealant): 56019-120

Austria, Germany, France, Italy, Netherlands, Switzerland, and UK Models

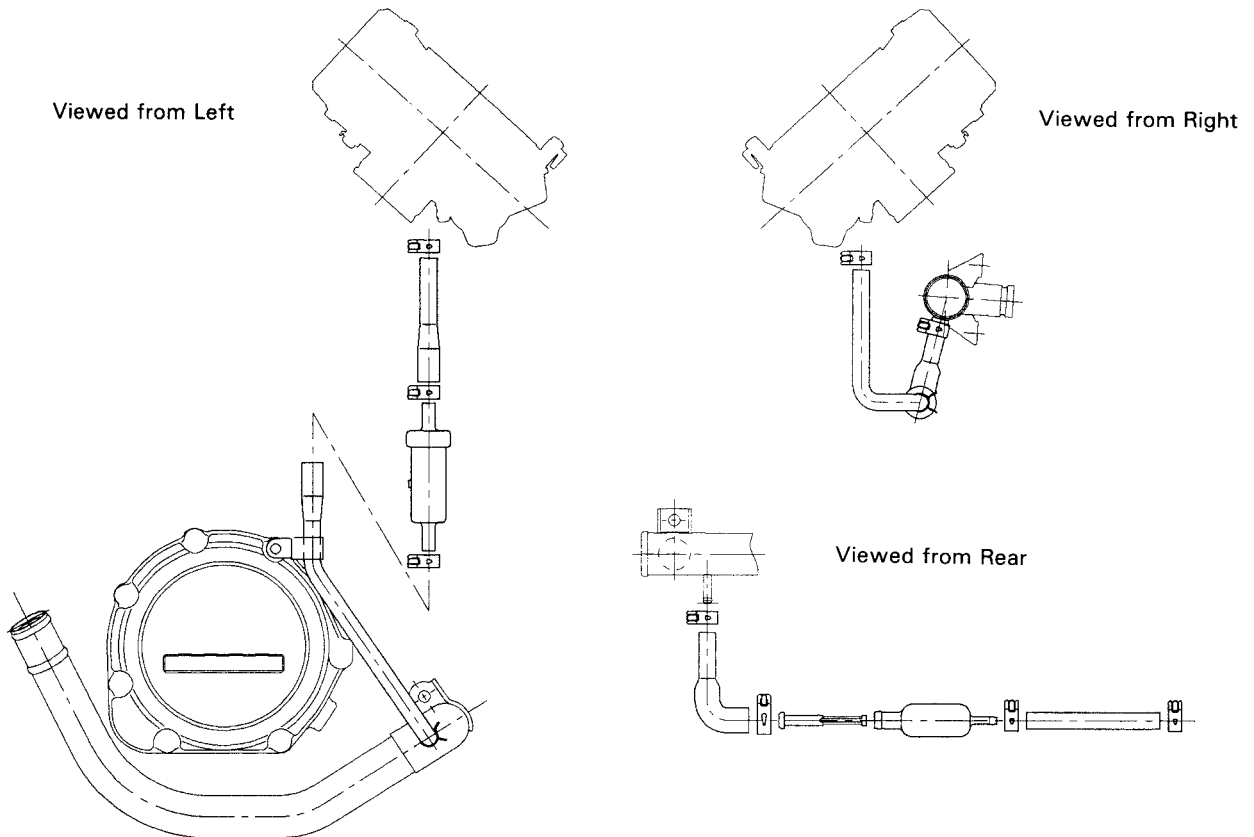

3-4 COOLING SYSTEM

Coolant

Coolant Level Inspection

NOTE

- Check the level when the engine is cold (room or ambient temperature).
- Check the coolant level in the reservoir tank with the motorcycle held perpendicular.
- ★ If the coolant level is lower than the "LOW" mark [A], add coolant to the "FULL" mark [B].

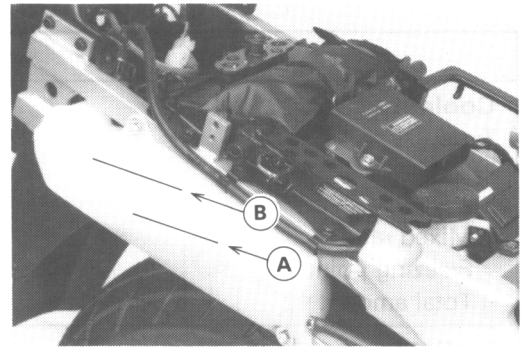

CAUTION

For refilling, add the specified mixture of coolant and soft water. Adding water alone dilutes the coolant and degrades its anticorrosion properties.

The diluted coolant can attack the aluminum engine parts. In an emergency, soft water can be added, but the diluted coolant must be returned to the correct mixture ratio within a few days.

If coolant must be added often, or the reservoir tank has run completely dry; there is probably leakage in the cooling system. Check the system for leaks.

Coolant Draining

⚠ WARNING

To avoid burns, do not remove the radiator cap or try to change the coolant when the engine is still hot. Wait until it cools down. Coolant on tires will make them slippery and can cause an accident and injury. Immediately wipe up or wash away any coolant that spills on the frame, engine, or other painted parts. Since coolant is harmful to the human body, do not use for drinking.

- Open the lid located in the inner fairing on the right of the fuel tank and remove the Radiator Cap [A].

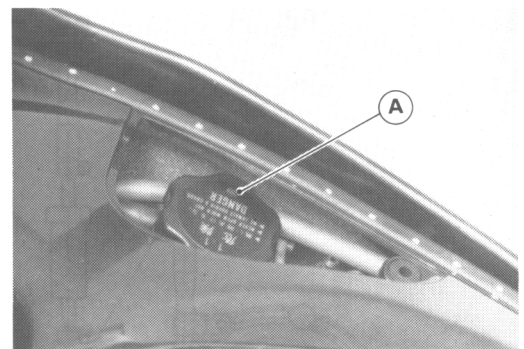

- Remove the drain plug [A] (bottom of water pipe [B]).

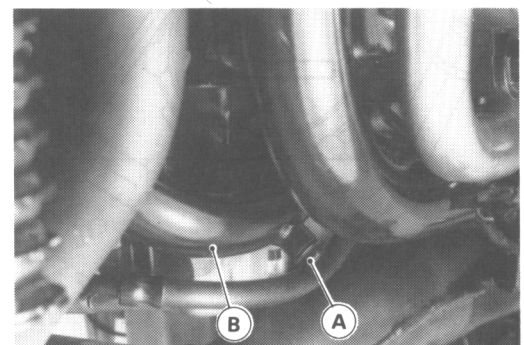

- Drain the coolant from the radiator.
- Pull off the reservoir tank hose [A] and pour the coolant into a container.

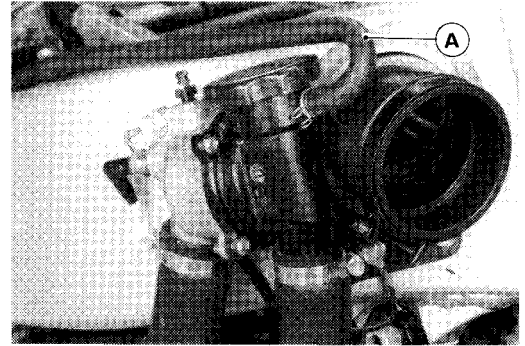

Coolant Filling

- Tighten the drain plug.
- Torque – Drain plug: 9.8N-m(1.0 kg-m, 87 in-lb)**
- Fill the radiator up to the thermostat housing [B] filter neck [A] with coolant, and install the radiator cap.

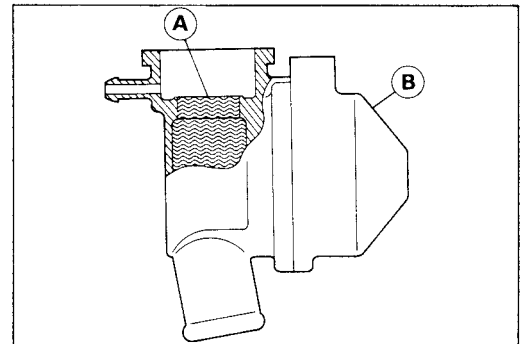

NOTE

- Pour in the coolant slowly so that it can expel the air from the engine and radiator.
- Fill the reservoir tank up to the "FULL" mark with coolant, and install the cap.

CAUTION

Soft or distilled water must be used with the antifreeze (see below for antifreeze) in the cooling system.
 If hard water is used in the system, it causes scales accumulation in the water passages, and considerably reduces the efficiency of the cooling system.

Water and Coolant Mixture Ratio(Recommended)

Soft Water	:	50%
Coolant	:	50%
Freezing Point	:	-35°C(-31°F)

NOTE

- Choose a suitable mixture ratio by referring to the coolant manufacturer's directions.

- Loosen the air bleeder bolt [A], until the coolant begins to flow out the air bleeder bolt hole (that is, when all the remaining air has been forced out).
- Tighten the air Bleeder bolt.

[B] Water Pump Cover Bolt

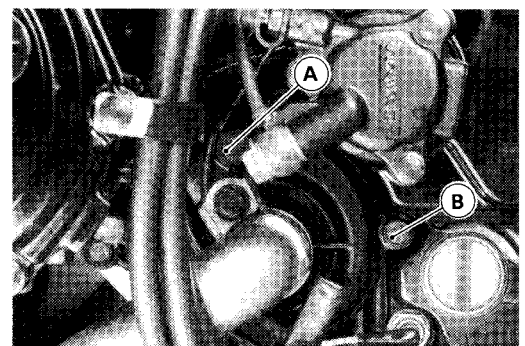

3-6 COOLING SYSTEM

- Start the engine, warm it up thoroughly until the radiator fan turns on and then stop the engine.
- Check the coolant level in the reservoir tank after the engine cools down.
- ★ If the coolant level is lower than the "LOW" mark, add coolant to the "FULL" mark.

CAUTION

Do not add more coolant above the "FULL" mark.

Pressure Testing

- Remove the radiator cap, and install a cooling system pressure tester [A] on the radiator filler neck.

NOTE

- *Wet the cap sealing surfaces with water or coolant to prevent pressure leaks.*
- Build up pressure in the system carefully until the pressure reaches 123 kPa (1.25 kg/cm², 18 psi).

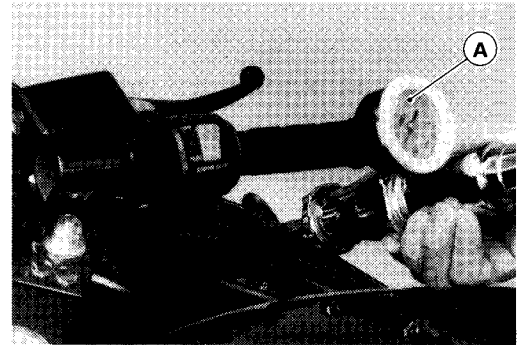

CAUTION

During pressure testing, do not exceed the pressure for which the system is designed. The maximum pressure is 123 kPa (1.25 kg/cm², 18psi).

- Watch the gauge for at least 6 seconds.
- ★ If the pressure holds steady, the system is all right.
- ★ If the pressure drops soon, check for leaks.

Water Pump

Removal

- Drain the coolant.
- Remove the inlet[A] and outlet water pipe [B].
- Unscrew the water pump mounting bolts(2), and pull out the water pump.

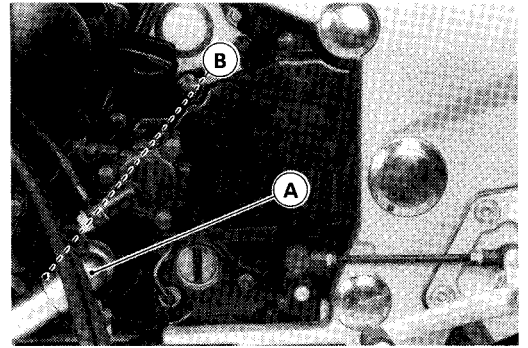

Installation

- Note the position of the oil pump shaft projection[A] and turn the water pump shaft[B] so that the projection fits into the slot.

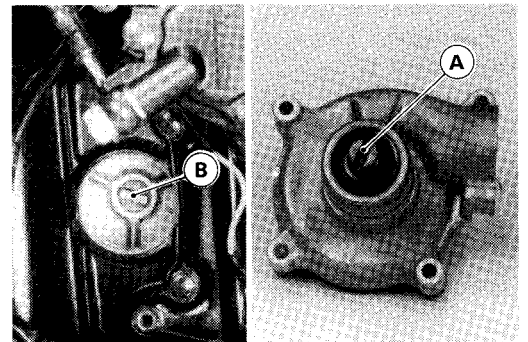

Water Pump Inspection

- Check the drainage outlet passage at the bottom of the water pump body for coolant leaks.
- ★ If the mechanical seal is damaged, the coolant leaks through the seal and drains through the passage [A]. Replace the water pump unit.

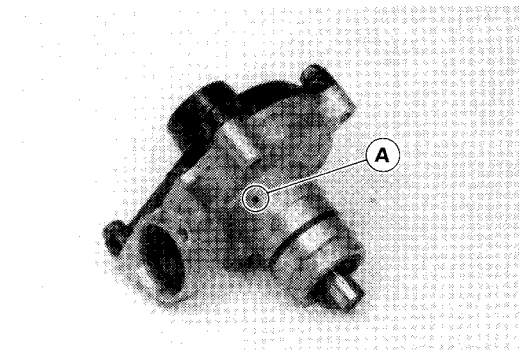

- Visually check the impeller[A].
- ★ If the surface is corroded, or if the blades are damaged, replace the water pump unit.

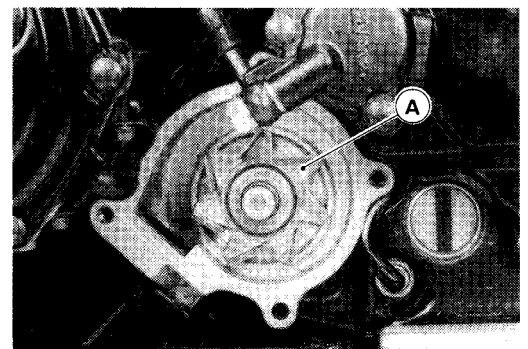

3-8 COOLING SYSTEM

Radiator and Radiator Fan

Removal

⚠WARNING

The radiator fan is connected directly to the battery. The radiator fan may start even if the ignition switch is off. NEVER TOUCH THE RADIATOR FAN UNTIL THE RADIATOR FAN CONNECTOR IS DISCONNECTED. TOUCHING THE FAN BEFORE THE CONNECTOR IS DISCONNECTED COULD CAUSE INJURY FROM THE FAN BLADES.

● Remove the following.

Fuel Tank

Upper and Lower

Fairings

Coolant (Drain)

Horns

Radiator Fan Connector [A] located in front of cylinder head cover.

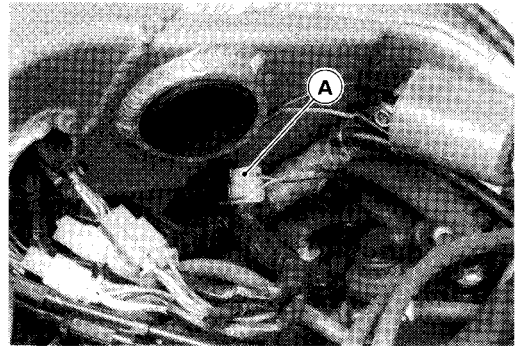

Fan Switch Leads [A]

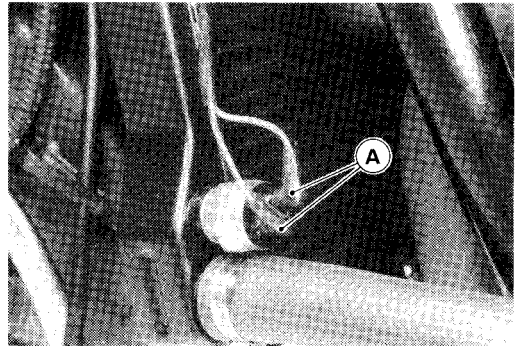

Radiator Hoses [A]

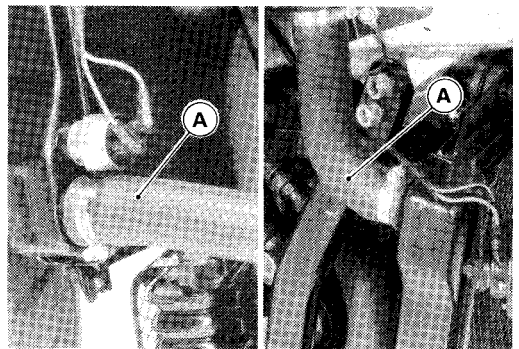

Radiator Screen [A]

Radiator Mounting Bolts [B]

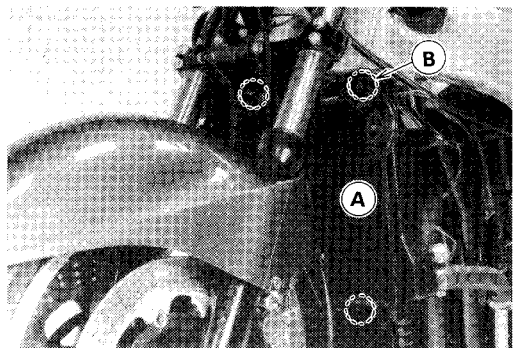

Radiator Fan Mounting Bolts [B]
 Radiator Fan [A]

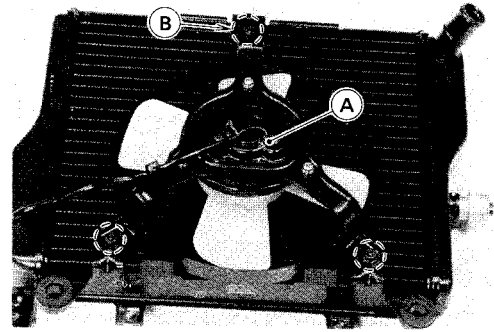

Radiator Inspection

- Check the radiator core.
- ★ If there are obstructions to air flow, remove them.
- ★ If the corrugated fins are deformed, carefully straighten them.
- ★ If the air passages of the radiator core are blocked more than 20% by unremovable obstructions or irreparably deformed fins, replace the radiator with a new one.

CAUTION

When cleaning the radiator with steam cleaner, be careful of the following to prevent radiator damage.

- 1) Keep the steam gun away more than 0.5 m from the radiator core.
- 2) Hold the steam gun perpendicular to the core surface.
- 3) Run the steam gun horizontally following the core fin direction. Running it vertically may damage the fin.

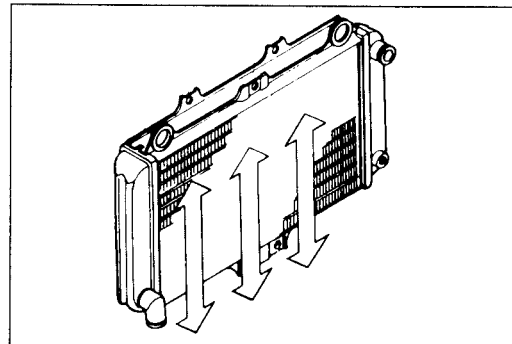

Radiator Cap Inspection

- Check the condition of the top [A] and bottom valve seals [B].
- ★ If any one of them shows visible damage, replace the cap.

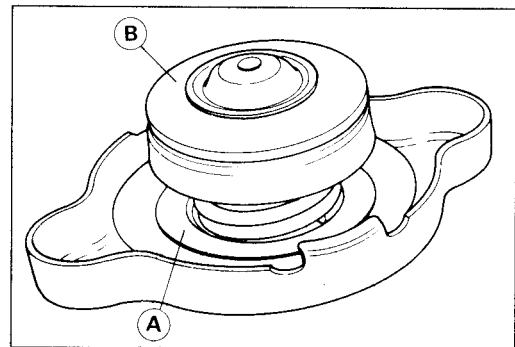

- Install the cap [B] on a cooling system pressure tester [A].

NOTE

- Wet the cap sealing surfaces with water or coolant to prevent pressure leaks.

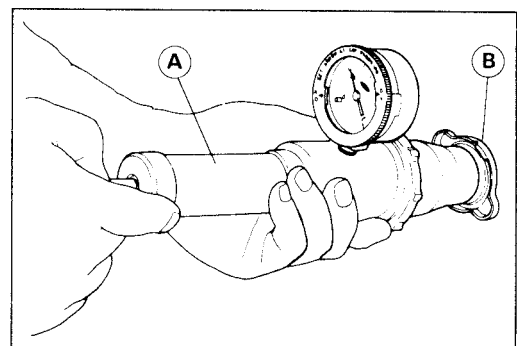

3-10 COOLING SYSTEM

- Watching the pressure gauge, pump the pressure tester to build up the pressure at least 6 seconds. Also the cap must open at the pressure shown in the table.

Radiator Cap Relief Pressure

Standard: 93 – 123 kPa
(0.95 – 1.25 kg/cm², 14 – 18psi)

- ★ If the cap cannot hold the specified pressure, or if it holds too much pressure, replace it with a new one.

Thermostat

Removal

- Fuel Tank
- Upper and Lower Fairings
- Coolant(drain)
- Reservoir Tank Hose [A]
- Sensor Connectors [B]
- Radiator Hoses [C]
- Mounting Bolts [D]
- Housing Screws [E]

● Unscrew the housing screws remove the thermostat.

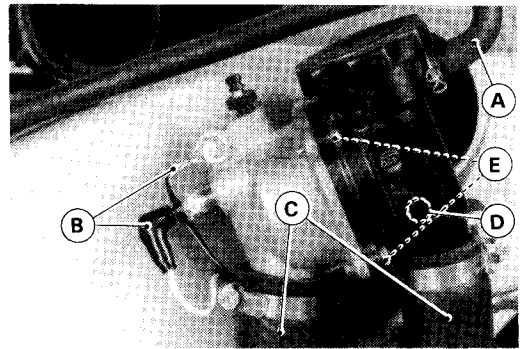

Installation

- Install the thermostat noting the following.
- Install the thermostat [A] in the housing so that the air hole [B] is on top.
- Be sure to install the O-ring to the housing.
- Fill the radiator with coolant.

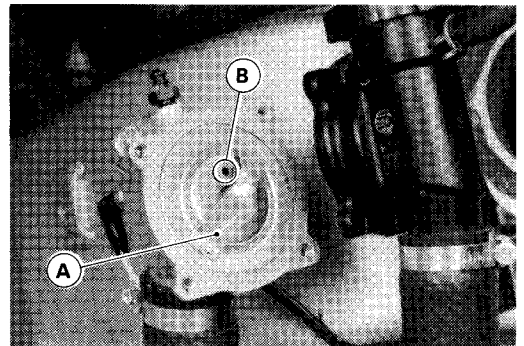

Inspection

- Remove the thermostat, and inspect the thermostat valve at room temperature.
- ★ If the valve is open, replace the valve with a new one.
- To check valve opening temperature, suspend the thermostat [A] in a container of water and raise the temperature of the water.
- [B] Thermometer
- ★ If the measurement is out is the service limit range, replace the thermostat.

Thermostat Valve Opening Temperature
80 – 84°C (176 – 183°F)

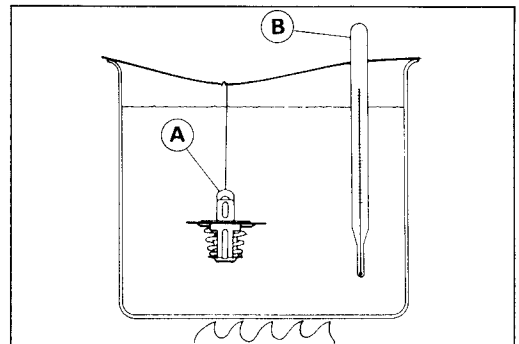

3-12 COOLING SYSTEM

Thermostat Fan Switch and Water Temperature Sensor

CAUTION

The fan switch [A] or the water temperature sensor [B] should never be allowed to fall on a hard surface. Such a shock to the parts can damage them.

- Refer to the Electrical System chapter for there inspection.

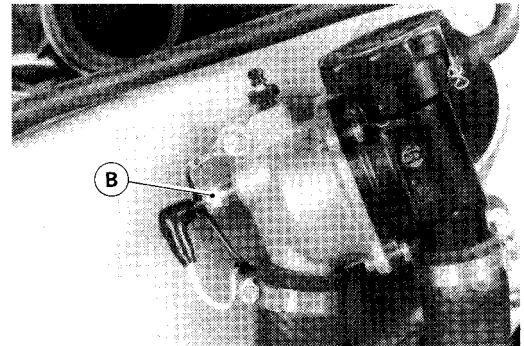
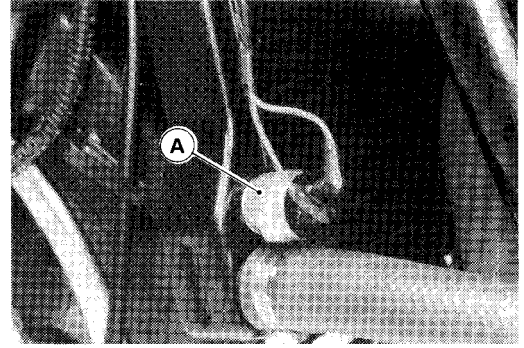

Engine Top End

Table of Contents

Exploded View	4-2	Removal	4-15
Specifications	4-4	Valve Removal	4-17
Special Tools	4-5	Valve Installation	4-18
Clean Air System	4-6	Valve Guide Removal	4-18
Air Suction Valve Inspection	4-6	Valve Guide Installation	4-18
Vacuum Switch Valve Installation Note	4-6	Seat Inspection	4-18
Vacuum Switch Valve Test	4-6	Seat Repair	4-19
Clean Air System Hose Inspection	4-7	Seat Cutter Operation Care:	4-19
Cylinder Head Cover	4-8	Marks Stamped on the Cutter:	4-19
Removal	4-8	Operating Procedures:	4-20
Installation	4-8	Valve-to-Guide Clearance Measurement	
Camshaft Chain Tensioner	4-9	(Wobble Method)	4-21
Removal	4-9	Cylinder, Piston	4-22
Installation	4-9	Cylinder Removal	4-22
Camshaft, Camshaft Chain, Rocker Shaft	4-10	Cylinder Installation	4-22
Camshaft, Rocker Shaft Removal	4-10	Piston Removal	4-22
Camshaft, Rocker Shaft Installation	4-10	Piston Installation	4-22
Chain Timing Procedure	4-11	Cylinder Wear	4-23
Camshaft and Sprocket Assembly	4-11	Piston Wear	4-23
Camshaft, Camshaft Cap Wear	4-12	Boring, Honing	4-23
Camshaft Chain Wear	4-12	Piston Ring, Piston Ring Groove Wear	4-24
Cylinder Head	4-13	Piston Ring End Gap	4-24
Cylinder Compression Measurement	4-13	Carburetor Holder	4-25
Removal	4-13	Carburetor Holder Installation	4-25
Installation	4-14	Muffler	4-26
Valves	4-15	Removal	4-26
Valve Clearance Adjustment	4-15		

4-2 ENGINE TOP END

Exploded View

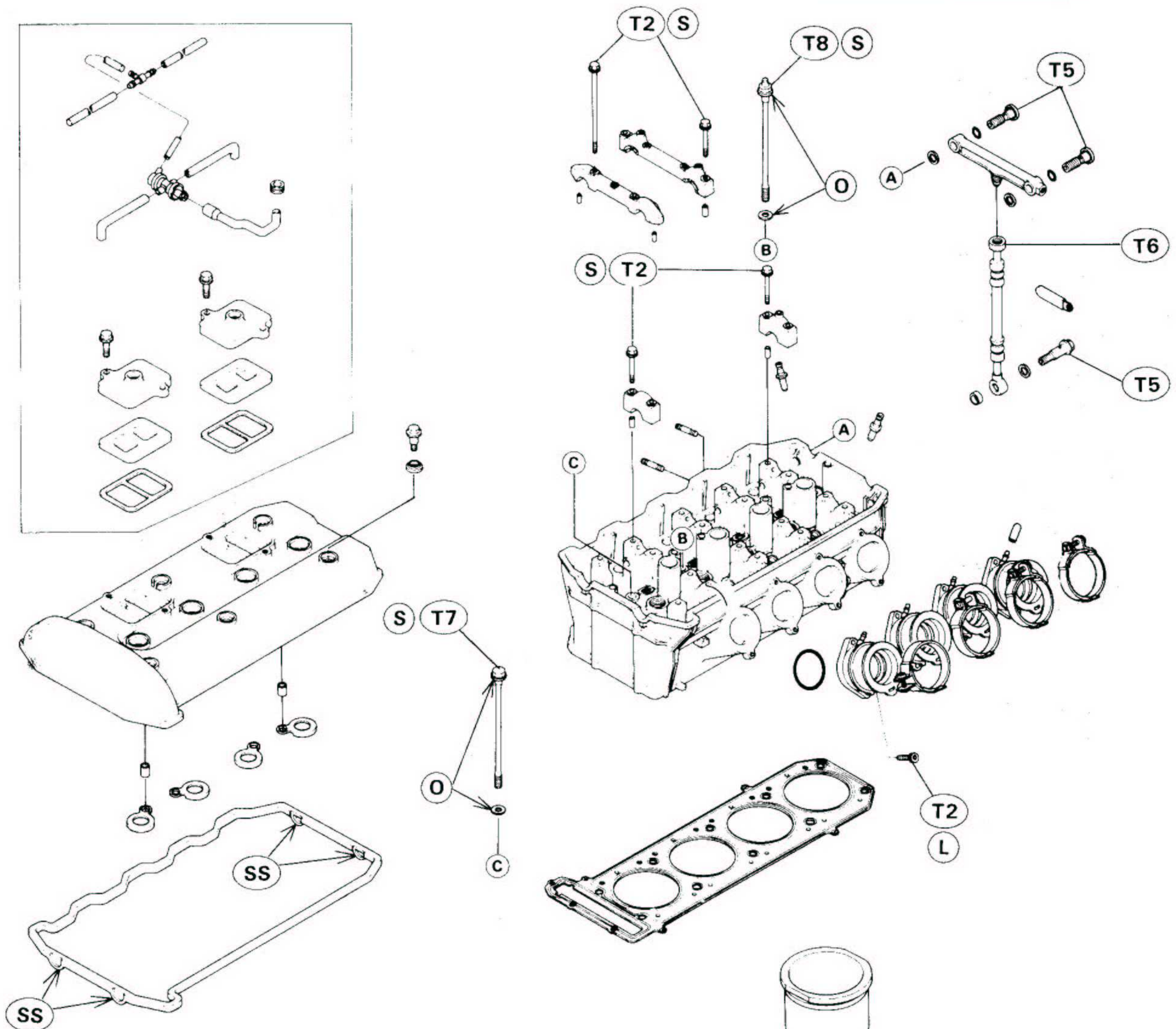

- M** : Apply molybdenum disulfide grease.
- L** : Apply non-permanent locking agent.
- O** : Apply oil.
- S** : Follow the specified tightening sequence.
- SS**: Apply silicone sealant.

- T1** : 9.8 N-m (1.0 kg-m, 87 in-lb)
- T2** : 12 N-m (1.2 kg-m, 104 in-lb)
- T3** : 15 N-m (1.5 kg-m, 11.0 ft-lb)
- T4** : 20 N-m (2.0 kg-m, 14.5 ft-lb)
- T5** : 25 N-m (2.5 kg-m, 18.0 ft-lb)
- T6** : 22 N-m (2.2 kg-m, 16.0 ft-lb)
- T7** : 39 N-m (4.0 kg-m, 29 ft-lb)
- T8** : 51 N-m (5.2 kg-m, 38 ft-lb)

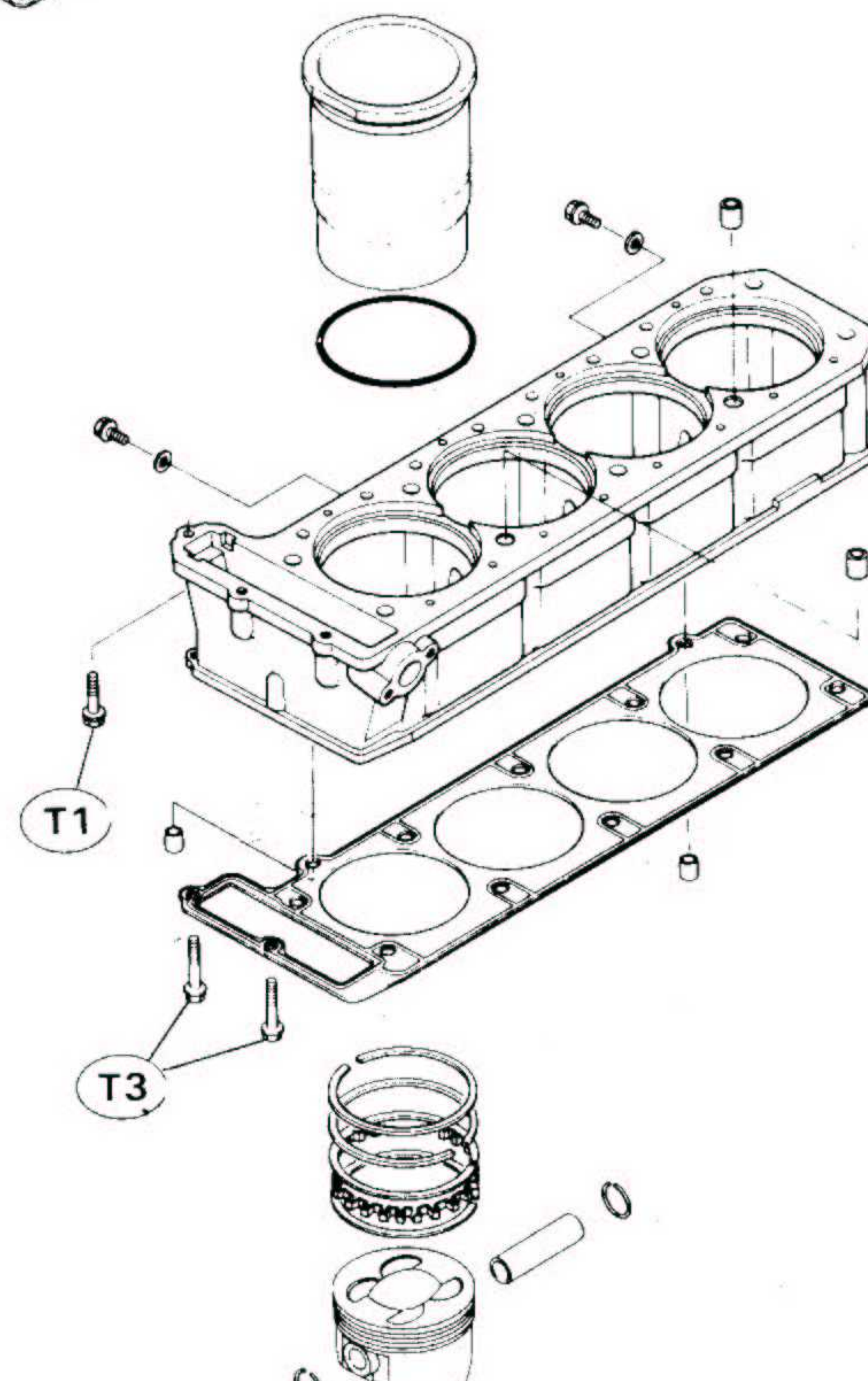

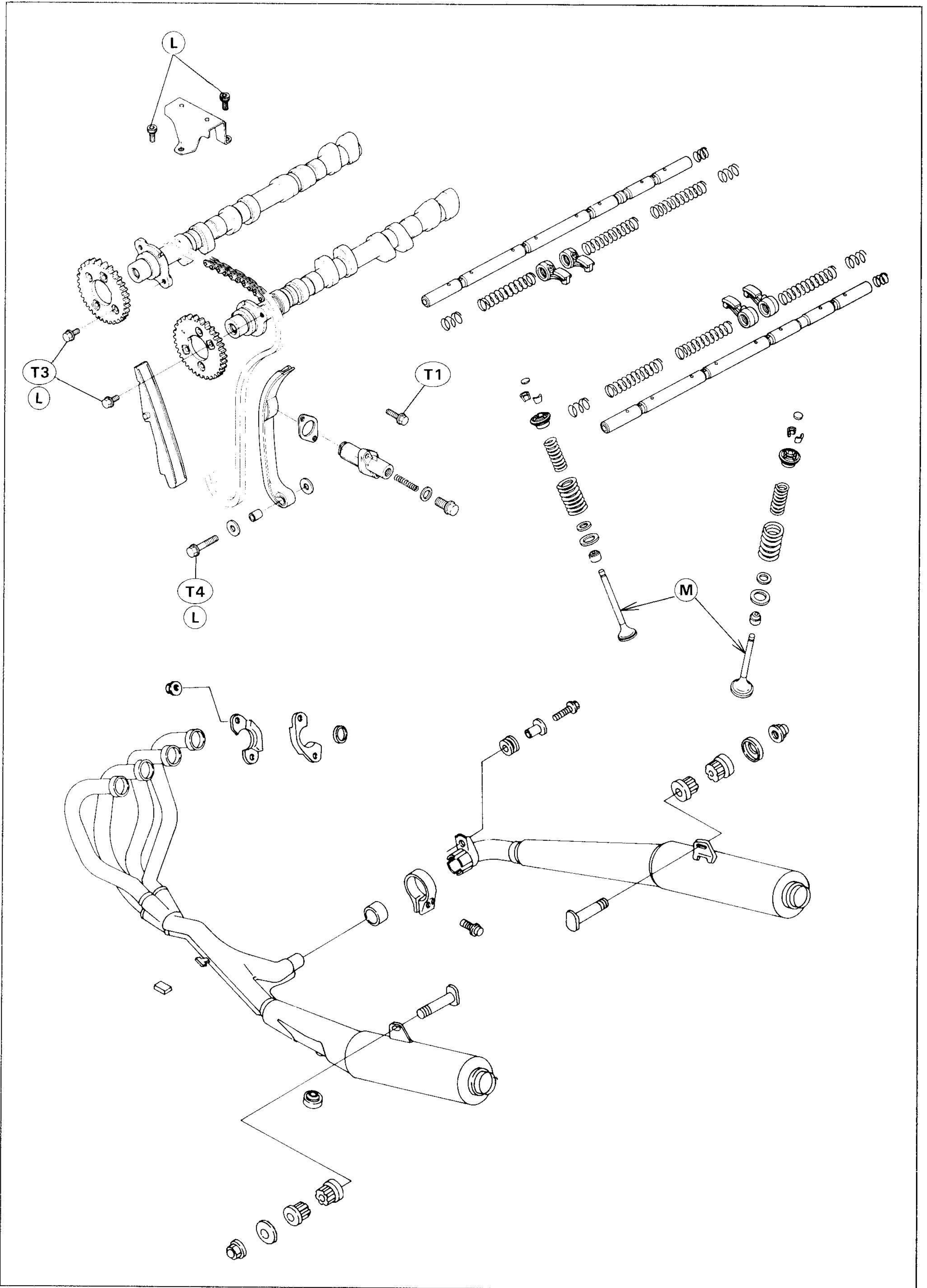

4-4 ENGINE TOP END

Specifications

Item	Standard	Service Limit
Clean Air System: Vacuum switch valve closing pressure: Open → Close	54 ~ 68 kPa (410 ~ 510 mm Hg)	---
Camshafts, Camshaft Chain, Rocker Shafts:		
Cam height: Inlet	36.872 ~ 36.972 mm	36.77 mm
Exhaust	36.687 ~ 36.787 mm	36.59 mm
Camshaft bearing oil clearance	0.078 ~ 0.121 mm	0.21 mm
Camshaft journal diameter	24.900 ~ 24.922 mm	24.87 mm
Camshaft bearing inside diameter	25.000 ~ 25.021 mm	25.08 mm
Camshaft runout	---	0.1 mm TIR
Camshaft chain 20-link length	158.8 ~ 159.2 mm	161.2 mm
Rocker arm inside diameter	12.000 ~ 12.018 mm	12.05 mm
Rocker shaft diameter	11.966 ~ 11.984 mm	11.94 mm
Cylinder Head:		
Cylinder compression	(usable range) 885 ~ 1 350 kPa (9.0 ~ 13.8 kg/cm ² , 128 ~ 196 psi) @320 r/min (rpm)	---
Cylinder head warp	---	0.05 mm
Valves:		
Valve clearance: Inlet	0.13 ~ 0.19 mm	---
Exhaust	0.18 ~ 0.24 mm	---
Valve head thickness: Inlet	0.5 mm	0.25 mm
Exhaust	0.8 mm	0.5 mm
Valve stem bend	---	0.05 mm TIR
Valve stem diameter: Inlet	4.975 ~ 4.990 mm	4.96 mm
Exhaust	4.955 ~ 4.970 mm	4.94 mm
Valve guide inside diameter	5.000 ~ 5.012 mm	5.08 mm
Valve/valve guide clearance (wobble method): Inlet	0.02 ~ 0.07 mm	0.18 mm
Exhaust	0.06 ~ 0.11 mm	0.21 mm
Valve seating surface: Outside diameter: Inlet	30.8 ~ 31.0 mm	---
Exhaust	26.3 ~ 26.5 mm	---
Width	0.5 ~ 1.0 mm	---
Valve spring free length: Inner	35.5 mm	33.6 mm
Outer	40.5 mm	38.6 mm
Valve seat cutting angle	32°, 45°, 60°	---
Cylinders, Pistons:		
Cylinder inside diameter	75.994 ~ 76.006 mm	76.10 mm
Piston diameter	75.918 ~ 75.938 mm	75.77 mm
Piston/cylinder clearance	0.056 ~ 0.088 mm	---
Piston ring/groove clearance: Top	0.03 ~ 0.07 mm	0.17 mm
Second	0.03 ~ 0.07 mm	0.17 mm
Piston ring groove width: Top	0.84 ~ 0.86 mm	0.94 mm
Second	0.82 ~ 0.84 mm	0.92 mm
Oil	2.51 ~ 2.53 mm	2.61 mm
Piston ring thickness: Top	0.77 ~ 0.79 mm	0.7 mm
Second	0.77 ~ 0.79 mm	0.7 mm
Piston ring end gap: Top	0.20 ~ 0.32 mm	0.7 mm
Second	0.20 ~ 0.35 mm	0.7 mm

Special Tools

Valve Head Thickness

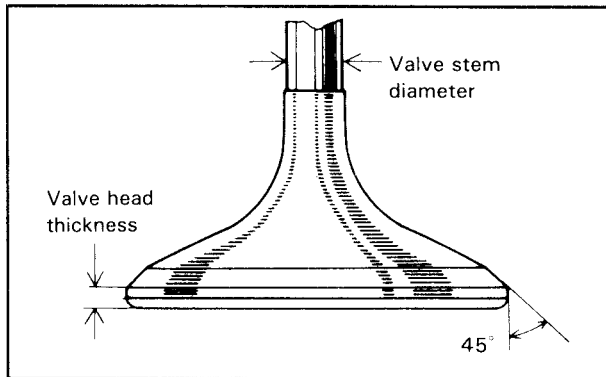

Valve Stem Bend

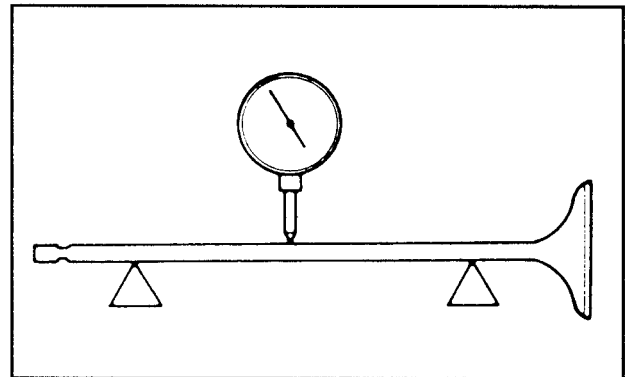

- Special Tool – Piston Ring Pliers: 57001-115**
Piston Base, $\Phi 6$: 57001-1263
Valve Guide Reamer, $\Phi 5$: 57001-1204
Valve Guide Arbor, $\Phi 5$: 57001-1203
Compression Gauge: 57001-221
Valve Spring Compressor Assembly: 57001-241
Piston Pin Puller Assembly: 57001-910
Valve Spring Compressor Adapter, $\Phi 22$: 57001-1202
Piston Ring Compressor Grip: 57001-1095
Piston Ring Compressor Belt, $\Phi 67 \sim \Phi 79$: 57001-1097
Valve Seat Cutter, 45° – $\Phi 27.5$: 57001-1114
Valve Seat Cutter, 45° – $\Phi 32$: 57001-1115
Valve Seat Cutter, 32° – $\Phi 30$: 57001-1120
Valve Seat Cutter, 32° – $\Phi 33$: 57001-1199
Valve Seat Cutter, 60° – $\Phi 30$: 57001-1123
Valve Seat Cutter, 60° – $\Phi 33$: 57001-1334
Valve Seat Cutter Holder, $\Phi 5$: 57001-1208
Valve Seat Cutter Holder Bar: 57001-1128
Spark Plug Wrench, Hex 16: 57001-1262
Vacuum Gauge: 57001-1369
Compression Gauge Adapter, M10 X 1.0: 57001-1317

- Sealant – Kawasaki Bond (Silicone Sealant): 56019-120**
Kawasaki Bond (Liquid Gasket – Silver): 92104-002

4-6 ENGINE TOP END

Clean Air System

Air Suction Valve Inspection

- Visually inspect the reeds [B] for cracks, folds, warps, heat damage, or other damage.
- ★ If there is any doubt as to the condition of the reed, replace the air suction valve as an assembly.
[A] Valve Holder

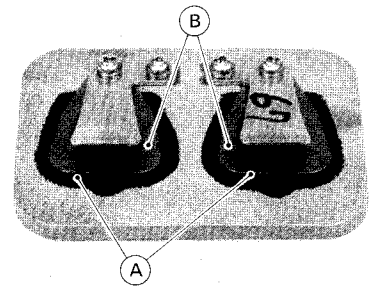

- Check the reed contact areas of the valve holder for grooves, scratches, any signs of separation from the holder, or heat damage.
- If there is any doubt as to the reed contact areas, replace the air suction valve as an assembly.
- If any carbon or other foreign particles have accumulated between the reed and the reed contact area, wash the valve assembly with high flash-point solvent.

CAUTION

Do not scrape off the deposits with a scraper as this could damaged the rubber, requiring replacement of the suction valve assembly.

Vacuum Switch Valve Installation Note

- Install the vacuum switch valve so that the air hole [A] faces downwards.
- Route the hoses correctly (see General Information chapter).

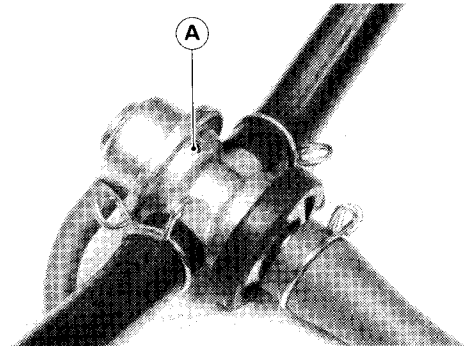

Vacuum Switch Valve Test

Using the vacuum gauge and a syringe, inspect the vacuum switch operation as follows:

- Remove the vacuum switch valve.
- Connect the vacuum gauge [A] and syringe [B] to the vacuum hoses as shown.

Special Tool – Vacuum Gauge: 57001-1369

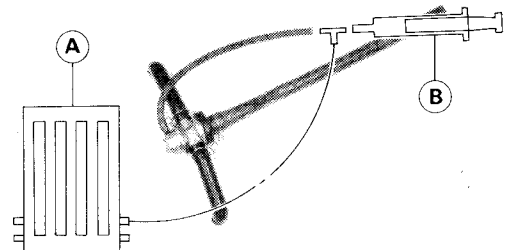

- Gradually raise the vacuum (lower the pressure) applied to the vacuum switch valve, and check the valve operation. When the vacuum is low, the vacuum switch valve should permit air to flow. When the vacuum raises to 57 ~ 65 kPa (430 ~ 490 mm Hg), it should stop air flow. When the vacuum is high enough, the air cannot flow through the valve.
- ★ If the vacuum switch valve does not operate as described, replace it with a new one.

NOTE

○ To check air flow through the vacuum switch valve, just blow through the air cleaner hose.

Vacuum Switch Valve Closing Pressure (Open → Close)

Standard: 54 ~ 68 kPa (410 ~ 510 mmHg)

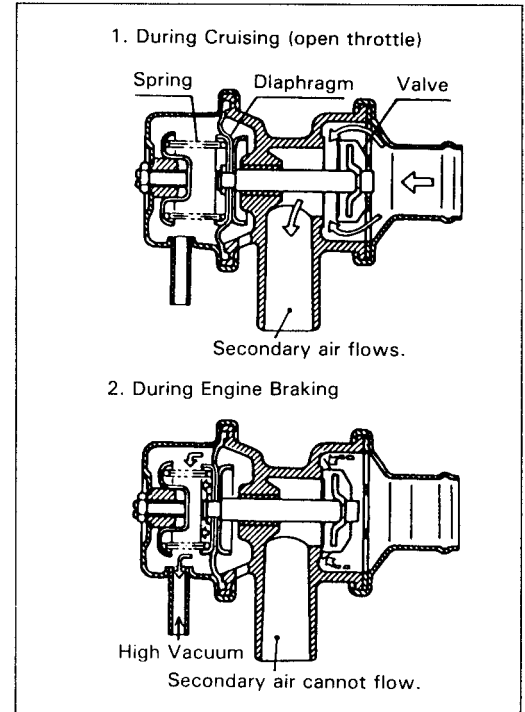

Clean Air System Hose Inspection

- Be certain that all the hoses are routed without being flattened or kinked, and are connected correctly to the air cleaner housing, vacuum switch valve, #1 and #4 carburetors and air suction valve covers.
- ★ If they are not, correct them. Replace them if they are damaged.

4-8 ENGINE TOP END

Cylinder Head Cover

Removal

- Remove the following.
 - Upper and Inner Fairings
 - Fuel Tank
 - Air Cleaner Housing
 - Ignition Coils [A]
 - Carburetor
 - Vacuum Switch Valve [B]
 - Rubber [C]
 - Baffle Plate [D]
- Remove the cylinder head cover bolts and take off the cover.

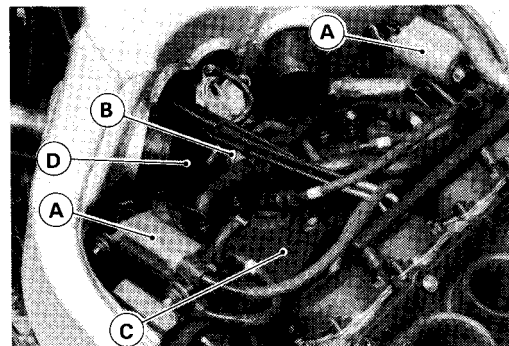

Installation

- Installation is the reverse of removal. Note the following.
- Apply silicone sealant to the cylinder head as shown [A].
- Tighten the cylinder head cover bolts.

Torque – Cylinder Head Cover Bolts: 9.8 N-m (1.0 kg-m, 87 in-lb)

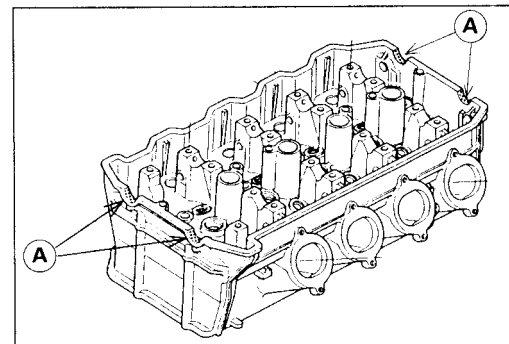

Camshaft Chain Tensioner

Removal

- Removal the tensioner cap bolt [D], copper washer [C], and the spring [B].
- Remove the mounting bolts [A] and take off the camshaft chain tensioner.

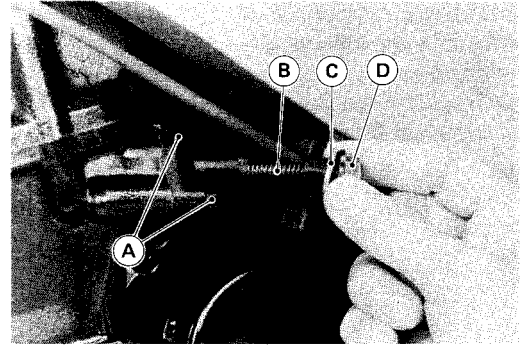

CAUTION

This is a non-return type cam chain tensioner. The push rod does not return to its original position once it moves out to take up cam chain slack. Observe all the rules listed below:

When removing the tensioner, do not take out the mounting bolts only halfway. Retightening the mounting bolts from this position could damage the tensioner and the camshaft chain. Once the bolts are loosened, the tensioner must be removed and reset as described in "Chain Tensioner Installation."

Do not turn over the crankshaft while the tensioner is removed. This could upset the cam chain timing, and damage the valves.

Installation

- Installation is the reverse of removal. Note the following.
- Release the stopper [B] and push into the rod [D].
 - [A] Push Rod
 - [C] Push
- Install the tensioner body [A] with the arrow [B] on it pointing upwards.
- Tighten the tensioner mounting bolts and cap bolt.
 - Torque – Tensioner Mounting Bolts: 9.8 N-m (1.0 kg-m, 87 in-lb)**

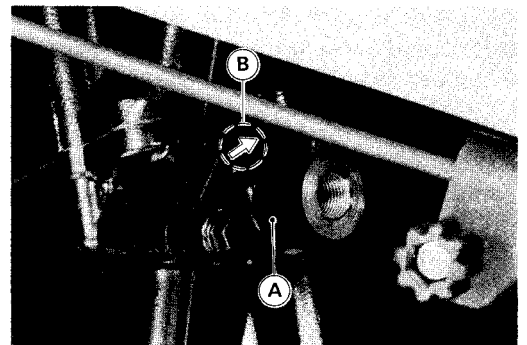
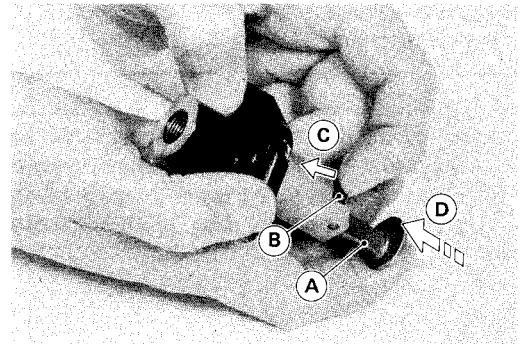

4-10 ENGINE TOP END

Camshaft, Camshaft Chain, Rocker Shaft

Camshaft, Rocker Shaft Removal

- Remove the following.
 - Carburetors
 - Cylinder Head Cover
 - Camshaft Chain Tensioner

- Remove the camshaft caps, and take off the camshaft.

NOTE

○ Remove the inlet rocker shaft, after removing the cylinder head.

- Remove the rocker shaft end bolt [A] and spring [B].

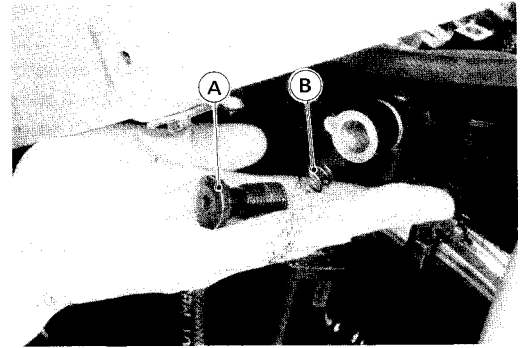

- Using a suitable bolt (M8 P 1.25 x more than 55 mm long) [A] pull the rocker shaft [B] out.

CAUTION

The crankshaft may be turned, while the camshafts are removed. Always pull the chain taut while turning the crankshaft. This avoids kinking the chain on the lower (crankshaft) sprocket. A kinked chain could damage both the chain and the sprocket.

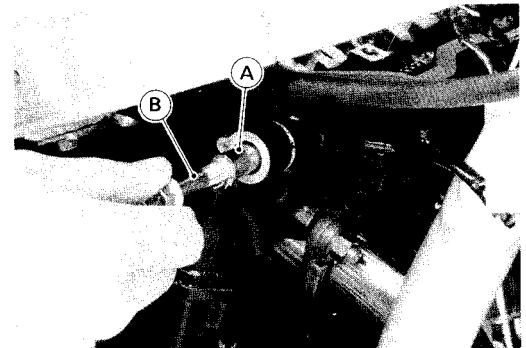

Camshaft, Rocker Shaft Installation

- Installation is the reverse of removal. Note the following.
- Apply engine oil to all cam parts and journals.

NOTE

○ The exhaust camshaft has an EX mark [A] and the inlet camshaft has an IN mark [B]. Be careful not to mix up these shafts.

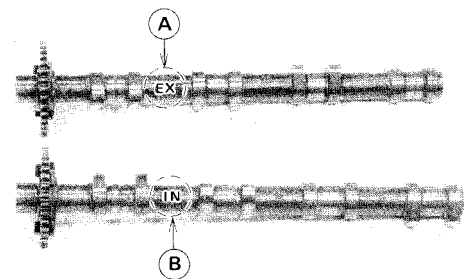

- Tighten the rocker shaft end bolts.

Torque – Rocker Shaft End Bolts : 25 N·m (2.5 kg·m, 18.0 ft·lb)

- Install the camshaft caps in the correct locations as shown.

CAUTION

The camshaft caps are machined with the cylinder head. So, if a cap is installed in a wrong location, the camshaft may seize because of improper oil clearance in the bearings.

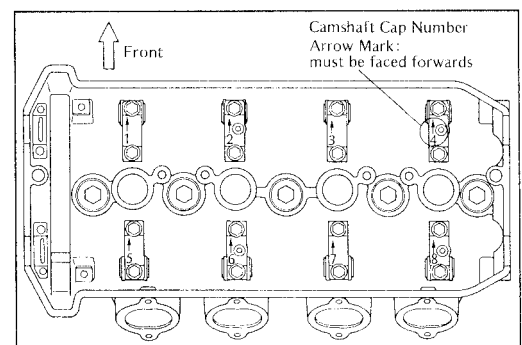

- First tighten down all camshaft cap bolts evenly to seat the camshafts in place, then torque all bolts.

Torque – Camshaft Cap Bolts : 12 N-m (1.2 kg-m, 104 in-lb)

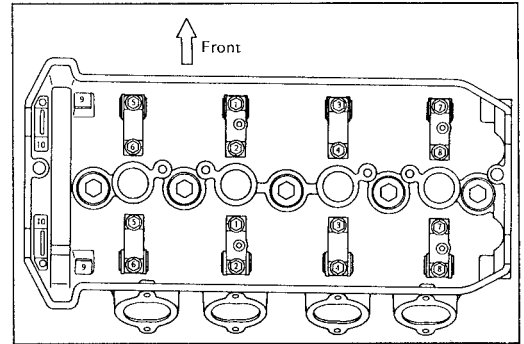

Chain Timing Procedure

- Position the crankshaft at TDC for the #1 and #4 pistons.
 - [A] Timing Mark
 - [B] TDC mark for #1 and #4 pistons
 - [C] TDC mark for #2 and #3 pistons

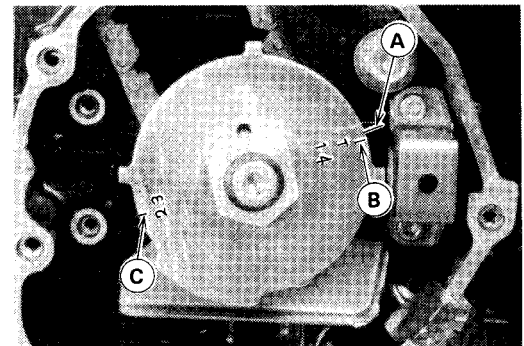

- Pull the tension side (exhaust side) of the chain taut to install the chain.
- The timing marks must be aligned with the cylinder head upper surface and positioned respectively as shown, after the camshaft chain slack is taken up by the tensioner.

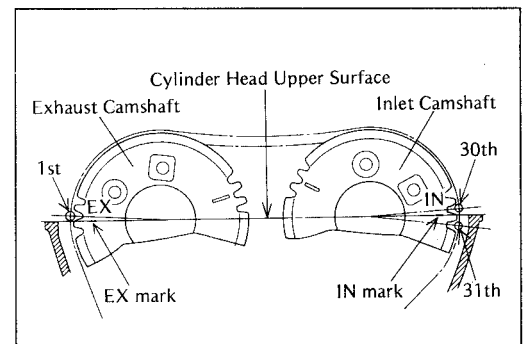

Camshaft and Sprocket Assembly

- Since the inlet and exhaust camshaft sprockets are the same, they have a set of bolt holes for the exhaust camshaft and another for the intake. Install the sprockets as shown.
 - [A] Bolt Holes for the Inlet Camshaft
 - [B] Bolt Holes for the Exhaust Camshaft

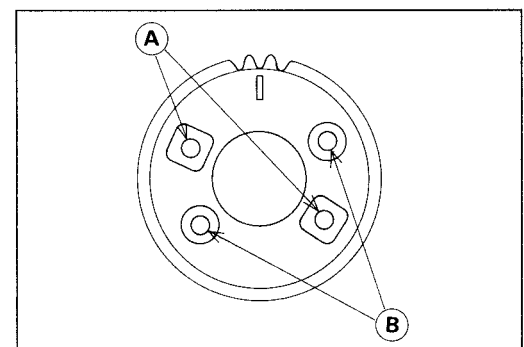

- Install the sprockets so that the marked side faces outwards.
- Apply a locking agent to the camshaft sprocket bolts and tighten them.

Torque – Camshaft Sprocket Bolts : 15 N-m(1.5kg-m, 11.0 ft-lb)

- If a new Camshaft is to be used, apply a thin coat of a molybdenum disulfide grease to the cam surfaces.

4-12 ENGINE TOP END

Camshaft, Camshaft Cap Wear

- Measure each clearance between the camshaft and the camshaft cap using plastigage (press gauge) [A].

NOTE

- Tighten the camshaft cap bolts.

Torque – Camshaft Cap Bolts: 12N-m (1.2 kg-m, 104 in-lb)

NOTE

- Do not turn the camshaft when the plastigage is between the journal and camshaft cap.

- ★ If any clearance exceeds the service limit, replace the camshaft with a new one and measure the clearance again.
- ★ If the clearance still remains out of the limit, replace the cylinder head unit.

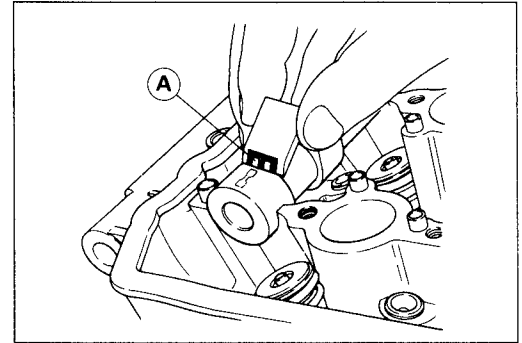

Camshaft Bearing Oil Clearance

Standard: 0.078 – 0.121 mm

Service Limit: 0.21 mm

Camshaft Chain Wear

- Hold the chain taut with a force of about 5 kg in some manner, and measure a 20-link length. Since the chain may wear unevenly, take measurements at several places.
- ★ If any measurement exceeds the service limit, replace the chain.

Camshaft Chain 20-link Length

Standard: 158.8 – 159.2 mm

Service Limit: 161.2 mm

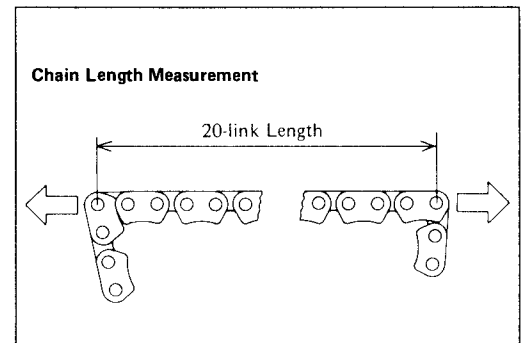

Cylinder Head

Cylinder Compression Measurement

- Warm up the engine thoroughly.
- Stop the engine, and remove one of the spark plugs from each cylinder.

Special Tool – Spark Plug Wrench, Hex 16: 57001-1262

- Measure the cylinder compression.
- Using the starter motor, turn the engine over with the throttle fully open until the compression gauge stops rising; the compression is the highest reading obtainable.

**Special Tool – Compression Gauge: 57001-221 [A]
Compression Gauge Adapter, M10 X 1.0: 57001-1317 [B]**

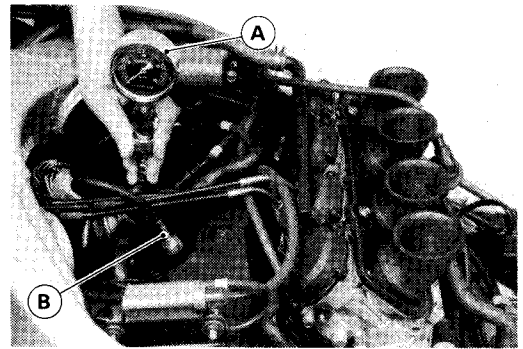

NOTE

- Be sure the battery is fully charged.
- Be sure no air leaks out of the cylinder head gasket.

Cylinder Compression

**Usable Range : 885 ~ 1350 kPa (9.0 ~ 13.8 kg/cm²
128 ~ 196 psi) @ 320 r/min (rpm)**

- Repeat the measurement for the other cylinder.
- ★ If cylinder compression is higher than the usable range, check the following:
 - (1) Carbon build - up on the cylinder head combustion chamber and the piston crown.
 - (2) Cylinder head gasket is not the original part.
 - (3) Valve stem oil seals and/or piston rings are damaged.
- ★ If cylinder compression is lower than the usable range, check the following:
 - (1) Condition of the valve seat is wrong.
 - (2) Valve clearance is too small.
 - (3) Piston/ Cylinder Clearance is excessive.
 - (4) Cylinder head is warped and/or head gasket is damaged.
 - (5) Piston ring/piston ring groove clearance is excessive.

Removal

- Remove the following.
 - Upper and Lower Fairings
 - Coolant (Drain)
 - Fuel Tank
 - Air Cleaner Housing
 - Radiator
 - Mufflers
 - Oil Hose (Cylinder head right side)
 - Carburetors
 - Cylinder Head Cover
 - Camshaft Chain Tensioner
 - Camshafts

NOTE

- Remove the cylinder head bolt (6 mm) [B] and the cylinder bolts [A] first, then remove the cylinder head bolts. This prevents excessive stress on the small bolts.
- Remove the cylinder head bolts and take off the cylinder head.

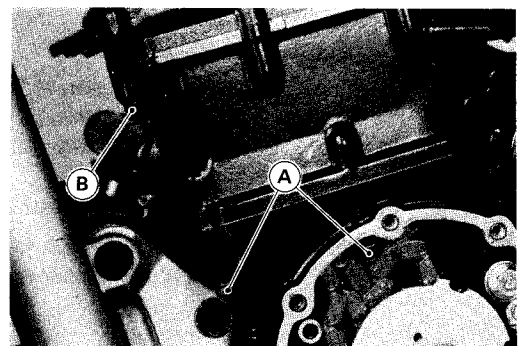

4-14 ENGINE TOP END

Installation

- Installation is the reverse of removal. Note the following.
- Install the left most camshaft cap [A] on the cylinder head.
- Install the two camshaft cap bolts [B] through the leftmost camshaft cap and cylinder head.
- Install the cylinder head on the cylinder.

NOTE

- The bolts can not be put into the leftmost camshaft cap after the cylinder head had been installed due to insufficient clearance between the camshaft cap bolts and the frame.

NOTE

- The camshaft caps are machined with the cylinder head so if a new cylinder head [A] is installed, use the caps that are supplied with the new head.
- Apply engine oil [C] to the both sides of the cylinder head bolt washer [B].

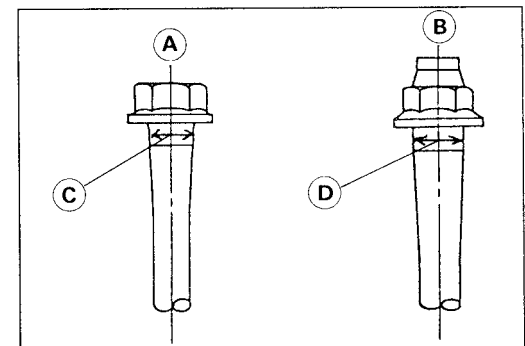
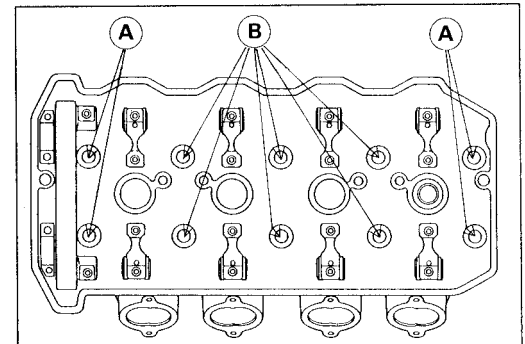
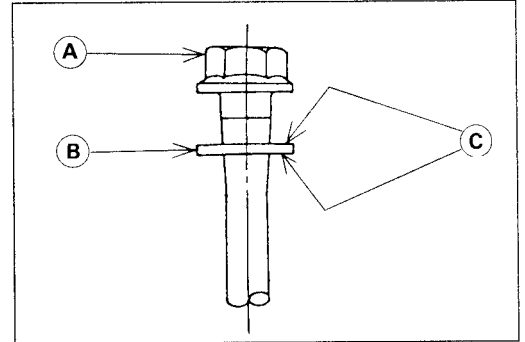
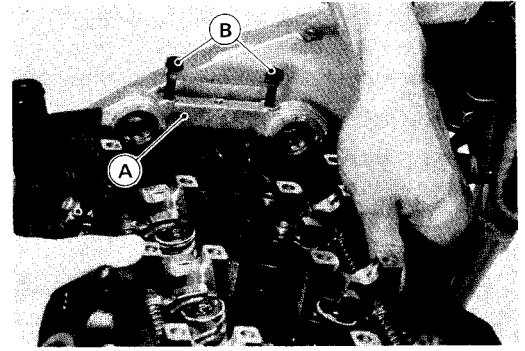

Location of Cylinder Head Bolts

10 mm Dia. Bolt	[A]
11 mm Dia. Bolt	[B]
10 mm	[C]
11 mm	[D]

- Torque the cylinder head bolts following the tightening sequence.

Torque – Cylinder Head Bolts:

First	20 N-m (2.0 kg-m, 14.5 ft-lb)
Final	11 mm dia: 51 N-m (5.2 kg-m, 38 ft-lb)
	10 mm dia: 39 N-m (4.0 kg-m, 29 ft-lb)

- Tighten the cylinder bolts and cylinder head bolt (6 mm).

Torque – Cylinder Bolts:	15 N-m (1.5 kg-m, 11.0 ft-lb)
Cylinder Head Bolt (6 mm):	9.8 N-m (1.0 kg-m, 87 in-lb)

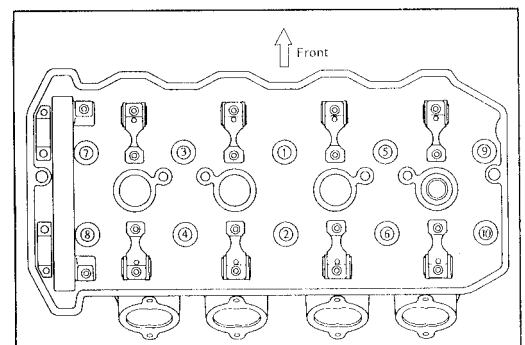

Valves

Valve Clearance Adjustment

NOTE

- Valve clearance must be checked and adjusted when the engine is cold (at room temperature).

Removal

- Upper and Inner Fairings
- Fuel Tank
- Air Cleaner Housing
- Ignition Coils
- Carburetor
- Vacuum Switch Valve
- Rubber
- Baffle Plate
- Pickup Coil Cover
- Cylinder Head Cover

- Using a thickness gauge, measure the valve clearance between the rocker arm and the shim.
- When positioning #4 piston TDC at the end of the compression stroke:
 - inlet valve clearance of #2 and #4 cylinders
 - exhaust valve clearance of #3 and #4 cylinders.

- When positioning #1 piston TDC at the end of the compression stroke:
 - inlet valve clearance of #1 and #3 cylinders
 - exhaust valve clearance of #1 and #2 cylinders.

- ★ If the valve clearance is not within the specified range, adjust the valve clearance and then adjust it.

Valve Clearance

- Standard: IN. 0.13 – 0.19 mm
- EX. 0.18 – 0.24 mm

NOTE

- To Select a new shim which brings valve clearance within the specification period. Refer to the Valve Clearance Adjustment charts.

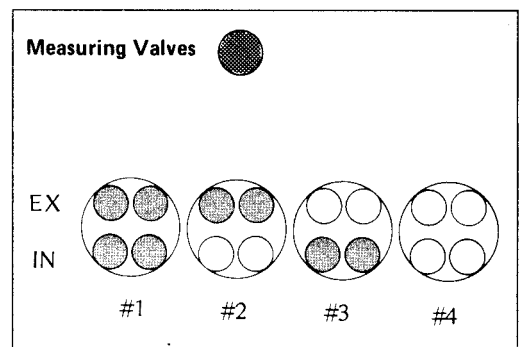
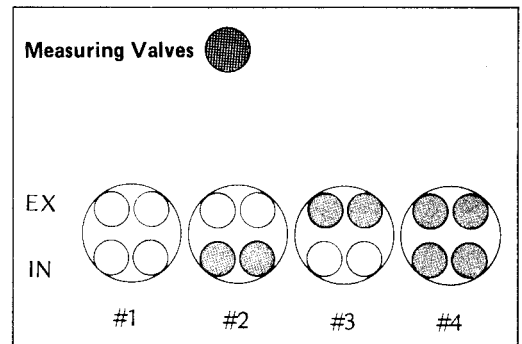

4-16 ENGINE TOP END

PART NUMBER (92025--)	PRESENT SHIM																				
	1870	1871	1872	1873	1874	1875	1876	1877	1878	1879	1880	1881	1882	1883	1884	1885	1886	1887	1888	1889	1890
THICKNESS (mm)	2.00	2.05	2.10	2.15	2.20	2.25	2.30	2.35	2.40	2.45	2.50	2.55	2.60	2.65	2.70	2.75	2.80	2.85	2.90	2.95	3.00

VALVE CLEARANCE (mm)	SPECIFIED CLEARANCE / NO CHANGE REQUIRED																				
	2.00	2.05	2.10	2.15	2.20	2.25	2.30	2.35	2.40	2.45	2.50	2.55	2.60	2.65	2.70	2.75	2.80	2.85	2.90	2.95	3.00
0.00 – 0.03																					
0.04 – 0.08																					
0.09 – 0.12																					
0.13 – 0.18																					
0.19 – 0.23																					
0.24 – 0.28																					
0.29 – 0.33																					
0.34 – 0.38																					
0.39 – 0.43																					
0.44 – 0.48																					
0.49 – 0.53																					
0.54 – 0.58																					
0.59 – 0.63																					
0.64 – 0.68																					
0.69 – 0.73																					
0.74 – 0.78																					
0.79 – 0.83																					
0.84 – 0.88																					
0.89 – 0.93																					
0.94 – 0.98																					
0.99 – 1.03																					
1.04 – 1.08																					
1.09 – 1.13																					
1.14 – 1.18																					

INSTALL THE SHIM OF THIS THICKNESS (mm)

Inlet Valve

1. Measure the clearance (When engine cold).
2. Check present shim size.
3. Match clearance in vertical column with present shim size in horizontal column.
4. The shim specified where the lines intersect is the one that will give you the proper clearance.

NOTE

○ If there is no clearance, select a shim which is several sizes smaller and then measure the clearance.

		PRESENT SHIM																				
PART NUMBER (92025--)		1870	1871	1872	1873	1874	1875	1876	1877	1878	1879	1880	1881	1882	1883	1884	1885	1886	1887	1888	1889	1890
THICKNESS (mm)		2.00	2.05	2.10	2.15	2.20	2.25	2.30	2.35	2.40	2.45	2.50	2.55	2.60	2.65	2.70	2.75	2.80	2.85	2.90	2.95	3.00

VALVE CLEARANCE (mm)	SPECIFIED CLEARANCE / NO CHANGE REQUIRED																					
	2.05	2.10	2.15	2.20	2.25	2.30	2.35	2.40	2.45	2.50	2.55	2.60	2.65	2.70	2.75	2.80	2.85	2.90	2.95	3.00		
0.00 - 0.03					2.00	2.05	2.10	2.15	2.20	2.25	2.30	2.35	2.40	2.45	2.50	2.55	2.60	2.65	2.70	2.75	2.80	
0.04 - 0.08				2.00	2.05	2.10	2.15	2.20	2.25	2.30	2.35	2.40	2.45	2.50	2.55	2.60	2.65	2.70	2.75	2.80	2.85	
0.09 - 0.13			2.00	2.05	2.10	2.15	2.20	2.25	2.30	2.35	2.40	2.45	2.50	2.55	2.60	2.65	2.70	2.75	2.80	2.85	2.90	
0.14 - 0.17		2.00	2.05	2.10	2.15	2.20	2.25	2.30	2.35	2.40	2.45	2.50	2.55	2.60	2.65	2.70	2.75	2.80	2.85	2.90	2.95	
0.18 - 0.23																						
0.24 - 0.28	2.05	2.10	2.15	2.20	2.25	2.30	2.35	2.40	2.45	2.50	2.55	2.60	2.65	2.70	2.75	2.80	2.85	2.90	2.95	3.00		
0.29 - 0.33	2.10	2.15	2.20	2.25	2.30	2.35	2.40	2.45	2.50	2.55	2.60	2.65	2.70	2.75	2.80	2.85	2.90	2.95	3.00			
0.34 - 0.38	2.15	2.20	2.25	2.30	2.35	2.40	2.45	2.50	2.55	2.60	2.65	2.70	2.75	2.80	2.85	2.90	2.95	3.00				
0.39 - 0.43	2.20	2.25	2.30	2.35	2.40	2.45	2.50	2.55	2.60	2.65	2.70	2.75	2.80	2.85	2.90	2.95	3.00					
0.44 - 0.48	2.25	2.30	2.35	2.40	2.45	2.50	2.55	2.60	2.65	2.70	2.75	2.80	2.85	2.90	2.95	3.00						
0.49 - 0.53	2.30	2.35	2.40	2.45	2.50	2.55	2.60	2.65	2.70	2.75	2.80	2.85	2.90	2.95	3.00							
0.54 - 0.58	2.35	2.40	2.45	2.50	2.55	2.60	2.65	2.70	2.75	2.80	2.85	2.90	2.95	3.00								
0.59 - 0.63	2.40	2.45	2.50	2.55	2.60	2.65	2.70	2.75	2.80	2.85	2.90	2.95	3.00									
0.64 - 0.68	2.45	2.50	2.55	2.60	2.65	2.70	2.75	2.80	2.85	2.90	2.95	3.00										
0.69 - 0.73	2.50	2.55	2.60	2.65	2.70	2.75	2.80	2.85	2.90	2.95	3.00											
0.74 - 0.78	2.55	2.60	2.65	2.70	2.75	2.80	2.85	2.90	2.95	3.00												
0.79 - 0.83	2.60	2.65	2.70	2.75	2.80	2.85	2.90	2.95	3.00													
0.84 - 0.88	2.65	2.70	2.75	2.80	2.85	2.90	2.95	3.00														
0.89 - 0.93	2.70	2.75	2.80	2.85	2.90	2.95	3.00															
0.94 - 0.98	2.75	2.80	2.85	2.90	2.95	3.00																
0.99 - 1.03	2.80	2.85	2.90	2.95	3.00																	
1.04 - 1.08	2.85	2.90	2.95	3.00																		
1.09 - 1.13	2.90	2.95	3.00																			
1.14 - 1.18	2.95	3.00																				
1.19 - 1.23	3.00																					

INSTALL THE SHIM OF THIS THICKNESS (mm)

Exhaust Valve

1. Measure the clearance (When engine cold).
2. Check present shim size.
3. Match clearance in vertical column with present shim size in horizontal column.
4. The shim specified where the lines intersect is the one that will give you the proper clearance.

NOTE

○ If there is no clearance, select a shim which is several sizes smaller and then measure the clearance.

- Side the rocker arm [B] sideways and change the shim [A].
- Remeasure the valve clearance that are adjusted. Readjust if necessary.

CAUTION

Do not put shim stock under the shim. This may cause the shim to pop out at high rpm, causing extensive engine damage.
Do not grind the shim. This may cause it to fracture, causing extensive engine damage.

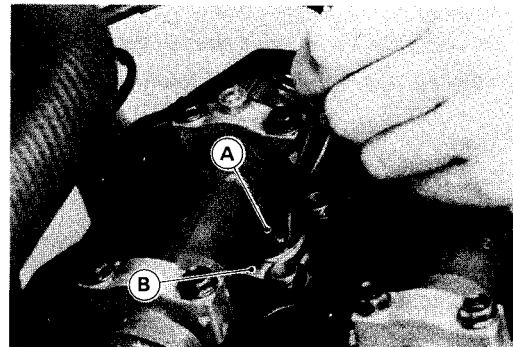

Valve Removal

- Special Tool – Valve Spring Compressor Assembly: 57001-241 [A]
- Valve Spring Compressor Adapter, Φ22: 57001-1202 [B]

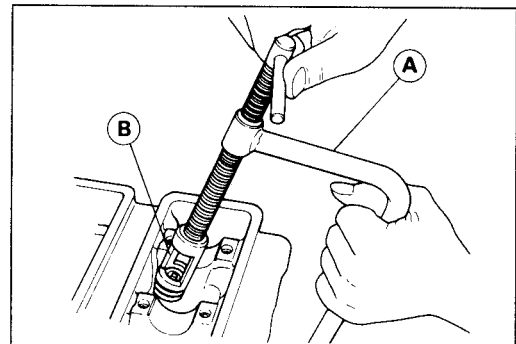

4-18 ENGINE TOP END

Valve Installation

- Apply a thin coat of molybdenum disulfide grease to the valve stem before valve installation.
- Install the springs so that the closed coil end faces downwards.
 - [A] Valve Stem
 - [B] Spring Seats
 - [C] Oil Seal
 - [D] Inner Spring
 - [E] Outer Spring
 - [F] Retainer
 - [G] Spring Seat
 - [H] Closed Coil End
 - [I] Split Keepers

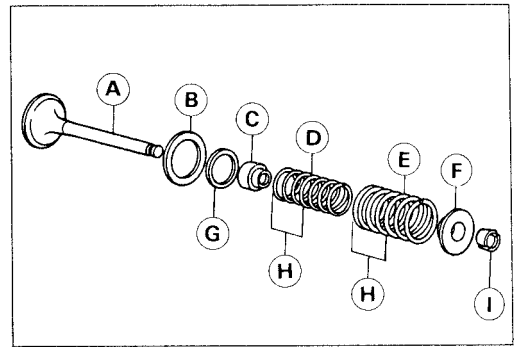

Valve Guide Removal

- Tap out the valve guide.

Special Tool – Valve Guide Arbor, $\phi 5$: 57001-1203 [A]

NOTE

- Heat the area around the valve guide to 120 – 150°C (248 – 302°F)

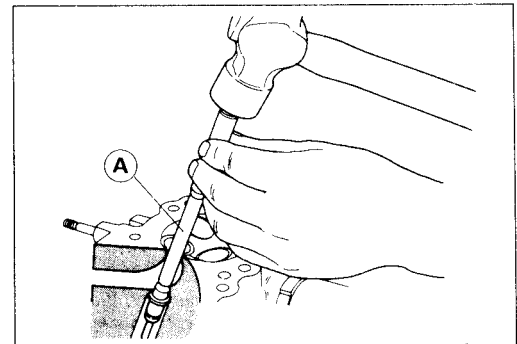

Valve Guide Installation

- Drive the valve guide until its flange touches to the cylinder head.

Special Tool – Valve Guide Arbor, $\phi 5$: 57001-1203

NOTE

- Heat the area around the valve guide hole to 120 – 150°C (248 – 302°F).
- Apply oil to the valve guide outer surface before valve guide installation.
- Using the valve guide reamer, ream the valve guide.

Special Tool – Valve Guide Reamer, $\phi 5$: 57001-1204 [A]

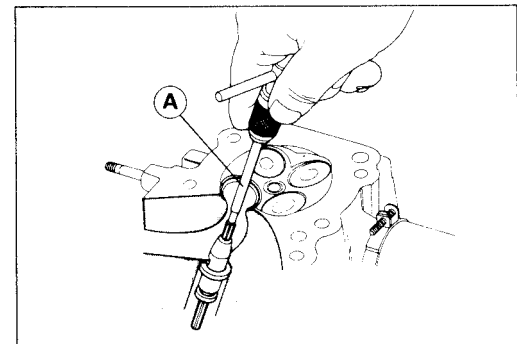

Seat Inspection

- Remove the valve.
- Check the valve seating surface [A] between the valve [B] and valve seat [C].
- Measure the outside diameter [D] of the seating pattern on the valve seat.
- ★ If the outside diameter is too large or too small, repair the seat (see Seat Repair).

Valve Seating Surface Outside Diameter

Standard: Inlet 30.8~31.0 mm
Exhaust 26.3~26.5 mm

- Measure the seat width [E] of the portion where there is no build-up carbon (white portion) of the valve seat with a vernier caliper.

- ★ If the width is too wide, too narrow or uneven, repair the seat (see Seat Repair).

Valve Seating Surface Width

Standard: Inlet, Exhaust 0.5 ~ 1.0 mm

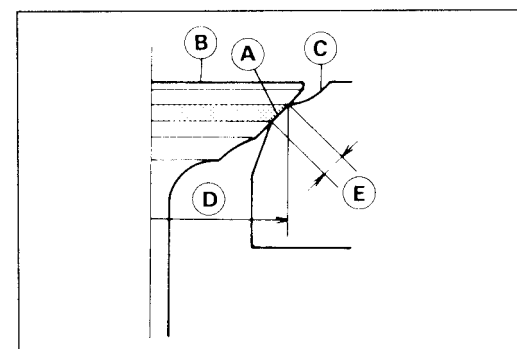

Seat Repair

● Repair the valve seat with the valve seat cutters.

Special Tool – Valve Seat Cutter Holder, $\Phi 5$: 57001-1208

Valve Seat Cutter Holder Bar: 57001-1128

[For Inlet Valve Seat]

Valve Seat Cutter, 45° – $\Phi 32$: 57001-1115

Valve Seat Cutter, 32° – $\Phi 33$: 57001-1199

Valve Seat Cutter, 60° – $\Phi 30$: 57001-1123

[For Exhaust Valve Seat]

Valve Seat Cutter, 45° – $\Phi 27.5$: 57001-1114

Valve Seat Cutter, 32° – $\Phi 30$: 57001-1120

Valve Seat Cutter, 60° – $\Phi 30$: 57001-1123

Valve Seat Cutter, 60° – $\Phi 33$: 57001-1334

★ If the manufacturer's instructions are not available, use the following procedure.

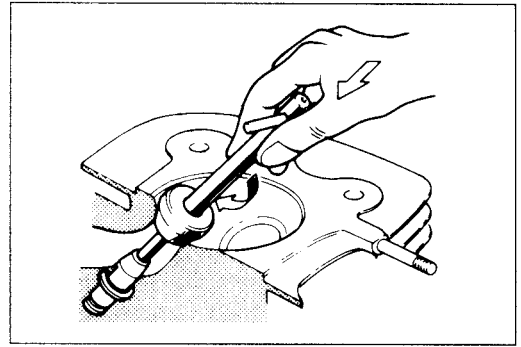

Seat Cutter Operation Care:

1. This valve seat cutter is developed to grind the valve for repair. Therefore the cutter must not be used for other purposes than seat repair.
2. Do not drop or shock the valve seat cutter, or the diamond particles may fall off.
3. Do not fail to apply engine oil to the valve seat cutter before grinding the seat surface. Also wash off ground particles sticking to the cutter with washing oil.

NOTE

○ Do not use a wire brush to remove the metal particles from the cutter. It will take off the diamond particles.

4. Setting the valve seat cutter holder in position, operate the cutter in one hand. Do not apply too much force to the diamond portion.

NOTE

○ Prior to grinding, apply engine oil to the cutter and during the operation, wash off any ground particles sticking to the cutter with washing oil.

5. After use, wash it with washing oil and apply thin layer of engine oil before storing.

*

Marks Stamped on the Cutter:

The marks stamped on the back of the cutter [A] represent the following.

60° Cutter angle [B]

37.5 ϕ Outer diameter of cutter [C]

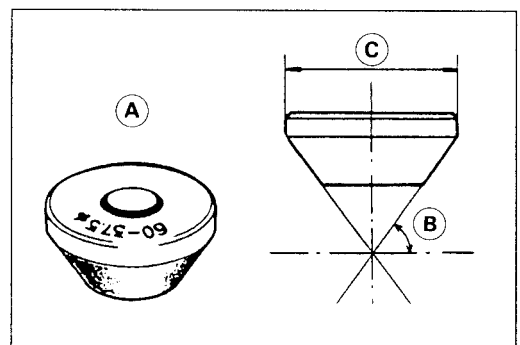

4-20 ENGINE TOP END

Operating Procedures:

- Clean the seat area carefully.
- Coat the seat with machinist's dye.
- Fit a 45° cutter into the holder and slide it into the valve guide.
- Press down lightly on the handle and turn it right or left. Grind the seating surface only until it is smooth.

CAUTION

Do not grind the seat too much. Overgrinding will reduce valve clearance by sinking the valve into the head. If the valve sinks too far into the head, it will be impossible to adjust the clearance, and the cylinder head must be replaced.

- Measure the outside diameter of the seating surface with a vernier caliper.
- ★ If the outside diameter of the seating surface is too small, repeat the 45° grind until the diameter is within the specified range.
- ★ If the outside diameter of the seating surface is too large, make the 32° grind described below.
- ★ If the outside diameter of the seating surface is within the specified range, measure the seat width as described below.
- Grind the seat at a 32° angle until the seat O.D. is within the specified range.
- To make the 32° grind, fit a 32° cutter into the holder, and slide it into the valve guide.
- Turn the holder one turn at a time while pressing down very lightly. Check the seat after each turn.

CAUTION

The 32° cutter removes material very quickly. Check the seat outside diameter frequently to prevent overgrinding.

- After making the 32° grind, return to the seat O.D. measurement step above.
 - To measure the seat width, use a vernier caliper to measure the width of the 45° angle portion of the seat at several places around the seat.
 - ★ If the seat width is too narrow, repeat the 45° grind until the seat is slightly too wide, and then return to the seat O.D. measurement step above.
 - ★ If the seat width is too wide, make the 60° grind described below.
 - ★ If the seat width is within the specified range, lap the valve to the seat as described below.
 - Grind the seat at a 60° angle until the seat width is within the specified range.
 - To make the 60° grind, fit 60° cutter into the holder, and slide it into the valve guide.
 - Turn the holder, while pressing down lightly.
 - After making the 60° grind, return to the seat width measurement step above.
 - Lap the valve to the seat, once the seat width and O.D. are within the ranges specified above.
 - Put a little coarse grinding compound on the face of the valve in a number of places around the valve head.
 - Spin the valve against the seat until the grinding compound produces a smooth, matched surface on both the seat and the valve.
 - Repeat the process with a fine grinding compound.
- [A] Lapper
[B] Valve Seat
[C] Valve
- The seating area should be marked about in the middle of the valve face.

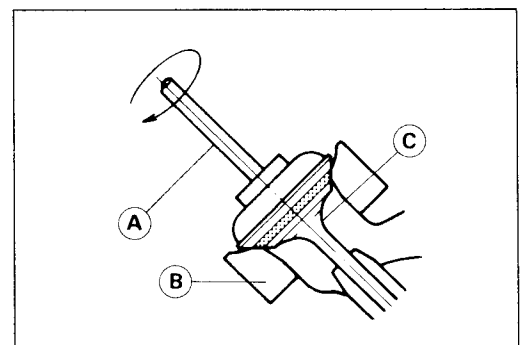
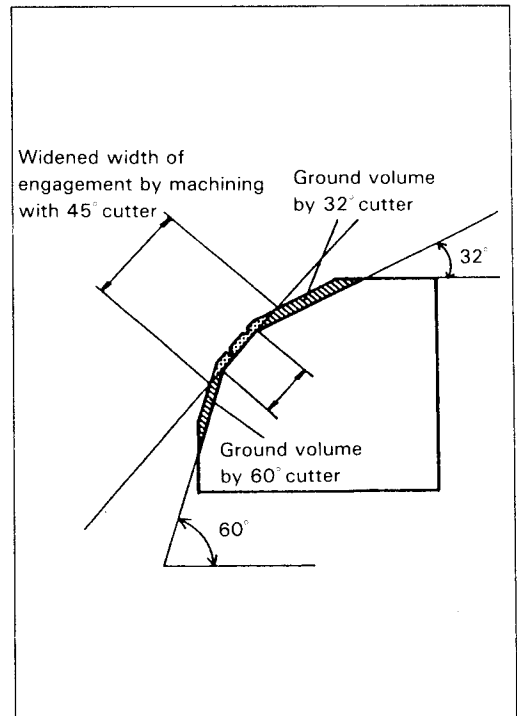

- ★ If the seat area is not in the right place on the valve, check to be sure the valve is the correct part. If it is, it may have been refaced too much; replace it.
- Be sure to remove all grinding compound before assembly.
- When the engine is assembled, be sure to adjust the valve clearance (see Valve Clearance Adjustment).

Valve-to-Guide Clearance Measurement (Wobble Method)

If a small bore gauge is not available, inspect the valve guide wear by measuring the valve to valve guide clearance with the wobble method as indicated below.

- Insert a new valve [A] into the guide [B] and set a dial gauge against the stem perpendicular it as close as possible to the cylinder head mating surface.
- Move the stem back and forth [C] to measure valve/valve guide clearance.
- Repeat the measurement in a direction at a right angle to the first.
- ★ If the reading exceeds the service limit, replace the guide.

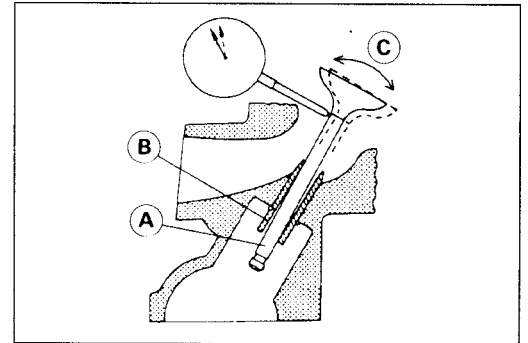

NOTE

○ The reading is not actual valve/valve guide clearance because the measuring point is above the guide.

Valve/Valve Guide Clearance (Wobble Method)

	Standard	Service Limit
Inlet	0.02 ~ 0.07 mm	0.18 mm
Exhaust	0.06 ~ 0.11 mm	0.21 mm

Cylinder Wear

● Since there is a difference in cylinder wear in different directions, take a side-to-side and a front-to-back measurement at each of the 3 locations (total of 6 measurements) shown in the figure.

★ If any of the cylinder inside diameter measurements exceeds the service limit, the cylinder will have to be bored to oversize and then honed.

[A] 10 mm

[B] 60 mm

[C] 20 mm

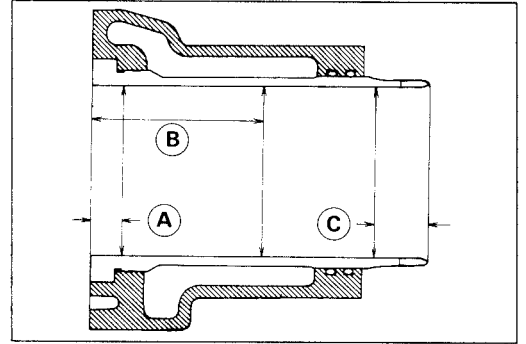

Cylinder Inside Diameter

Standard: 75.994 ~ 76.006 mm

Service Limit: 76.10 mm

Piston Wear

● Measure the outside diameter of each piston 5 mm [A] up from the bottom of the piston at a right angle to the direction of the piston pin.

★ If the measurement is under service limit, replace the piston.

Piston Diameter

Standard: 75.918 ~ 75.938 mm

Service Limit: 75.77 mm

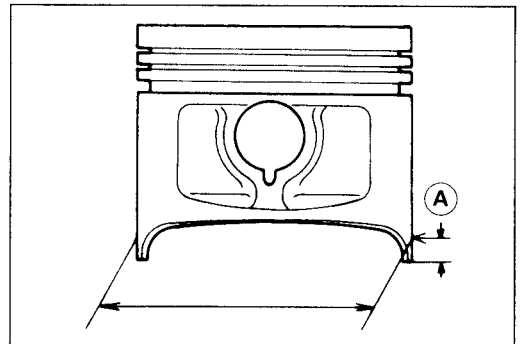

*

4-24 ENGINE TOP END

Piston Ring, Piston Ring Groove Wear

- Check for uneven groove wear by inspecting the ring seating.
- ★ The rings should fit perfectly parallel to groove surfaces. If not, the piston must be replaced.
- With the piston rings in their grooves, make several measurements with a thickness gauge to determine piston ring/groove clearance.

Piston Ring/Groove Clearance

	Standard	Service Limit
Top	0.03 ~ 0.07 mm	0.17 mm
Second	0.03 ~ 0.07 mm	0.17 mm

Piston Ring End Gap

- Place the piston ring [A] inside the cylinder, using the piston to locate the ring squarely in place. Set it close to the bottom of the cylinder, where cylinder wear is low.
- Measure the gap [B] between the ends of the ring with a thickness gauge.

Piston Ring End Gap

	Standard	Service Limit
Top	0.20 ~ 0.32 mm	0.7 mm
Second	0.20 ~ 0.35 mm	0.7 mm

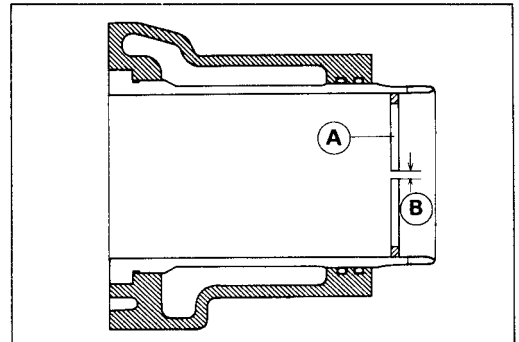
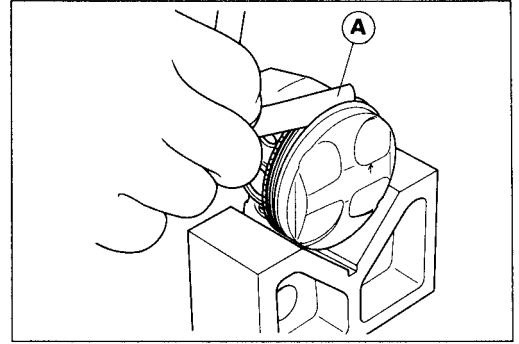

Carburetor Holder

Carburetor Holder Installation

- Install the carburetor holder so that the pipe is upward. Be careful of the clamp screw position [A].

⚠ WARNING

Operation with an improperly installed carburetor holder clamps could result in an unsafe riding condition.

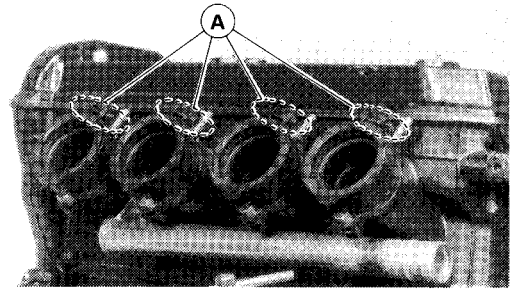

4-26 ENGINE TOP END

Muffler

Removal

- Remove the following
 - Upper and Lower Fairings
 - Coolant (draining)
 - Radiator
 - Horns (both left and right)
- Remove the nut [A] and take off the exhaust pipe holders [B].

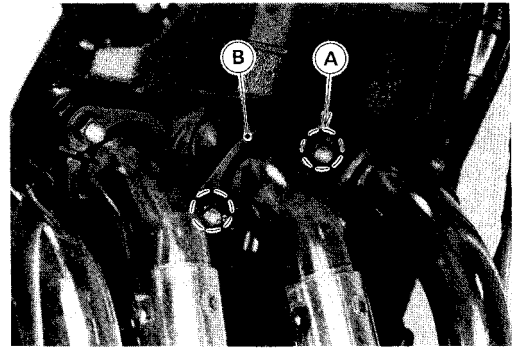

- Loosen the muffler clamp bolt.
- Remove the muffler mounting bolts.

[A] Exhaust Pipes	[D] Muffler
[B] Holders	[E] Mounting Bolt
[C] Exhaust Gasket	[F] Clamp

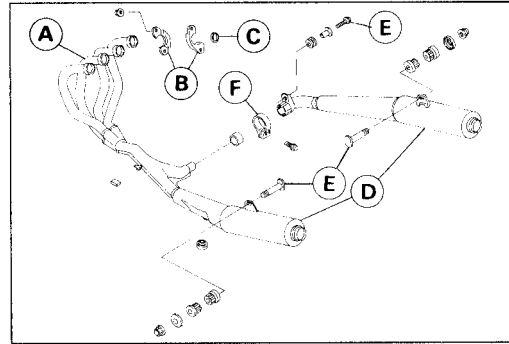

Clutch

Table of Contents

Exploded View	5-3
Specifications	5-5
Clutch Fluid	5-6
Fluid Level Inspection	5-6
Clutch Fluid Changing	5-6
Bleeding the Clutch Line	5-7
Master Cylinder	5-8
Installation	5-8
Disassembly	5-8
Assembly	5-8
Inspection	5-8
Clutch Slave Cylinder	5-9
Removal	5-9
Installation	5-9
Disassembly	5-9
Assembly	5-10
Clutch	5-11
Removal	5-11
Installation	5-12
Friction Plate Wear	5-13
Friction and Steel Plate Warp	5-13
Clutch Spring Free Length Measurement	5-14
Cam Damper Inspection	5-14

5-2 CLUTCH

Exploded View

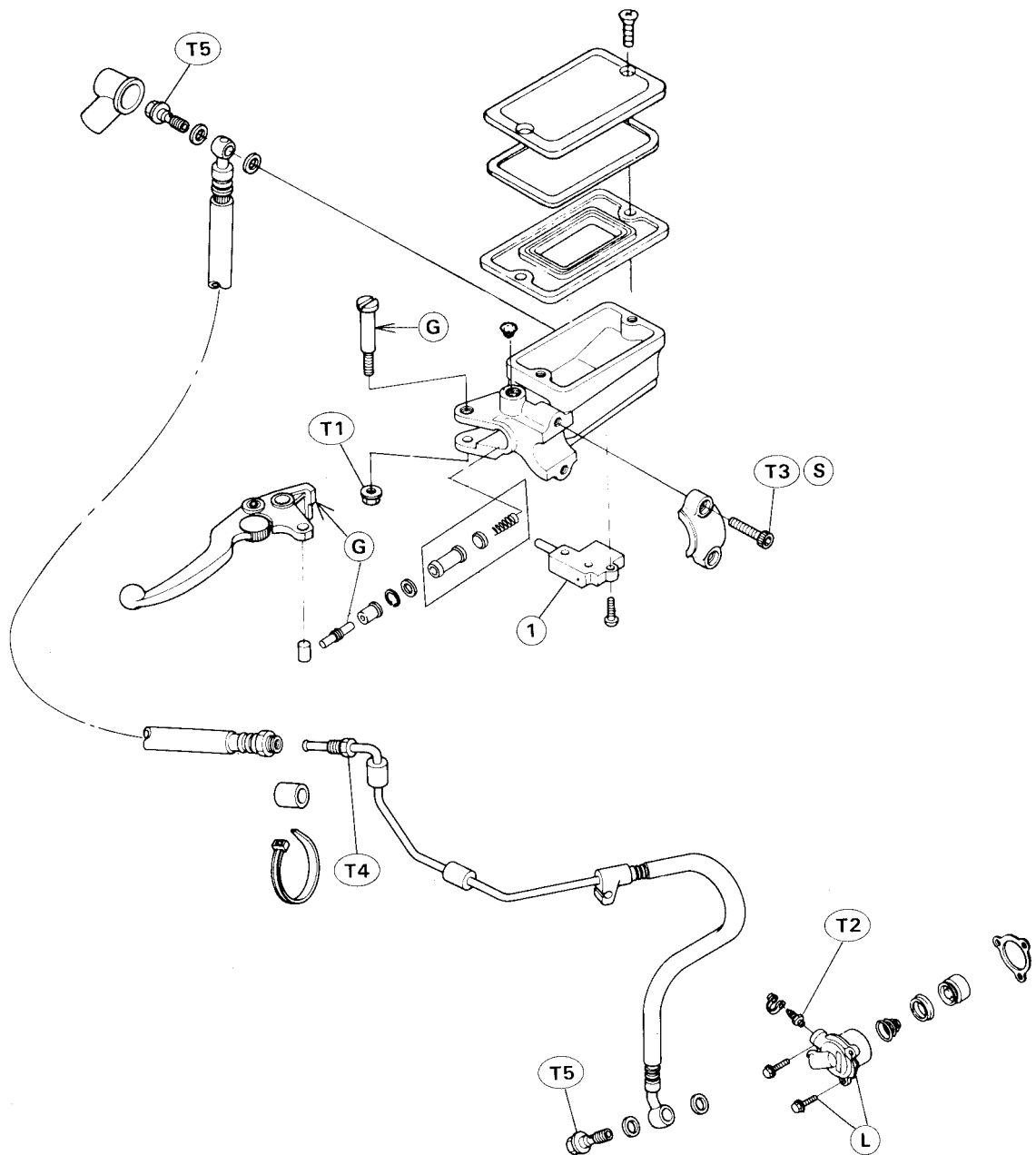

1. Starter Lockout Switch

G. Apply grease.

L. Apply non-permanent locking agent.

M. Apply molybdenum disulfide grease.

S. Follow the specified tightening sequence.

T1: 5.9 N-m(0.60 kg-m, 52 in-lb)

T2: 7.8 N-m(0.80 kg-m, 69 in-lb)

T3: 11 N-m(1.1 kg-m, 95 in-lb)

T4: 18 N-m(1.8 kg-m, 13.0 in-lb)

T5: 25 N-m(2.5 kg-m, 18.0 in-lb)

T6: 130 N-m(13.5 kg-m, 98 in-lb)

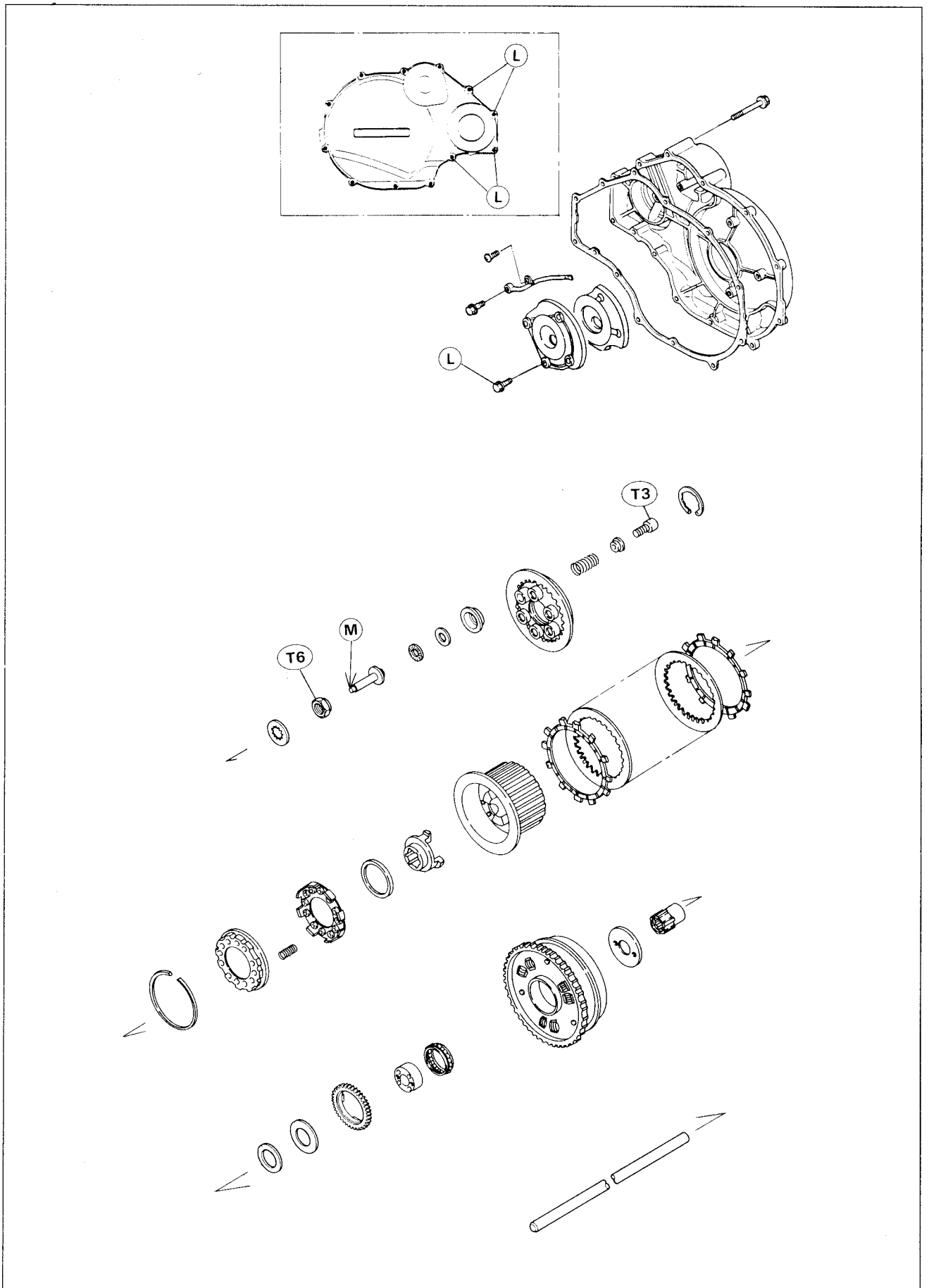

5-4 CLUTCH

Specifications

Item	Standard	Service Limit
Clutch Fluid: Grade Brand(recommended)	D.O.T.4 Castrol Girling-Universal Castrol GT(LMA) Castrol Disc Brake Fluid Castrol Shock Premium Heavy Duty	--- --- --- --- ---
Clutch: Clutch spring free length Friction plate thickness Friction and steel plate warp	46.3 mm 2.7 ~ 3.0 mm ---	42.7 mm 2.5 mm 0.3 mm

Special Tool – Kawasaki Bond (Silicone Sealant): 56019-120

Clutch Fluid

Fluid Level Inspection

- Check the clutch fluid level in the reservoir.
 - Lower Level Line[A]
 - Upper Level Line[B]

NOTE

- Hold the reservoir horizontal when checking clutch fluid level.

- ★ If the fluid level is lower than the lower level line, fill the reservoir to the upper level line in the reservoir.

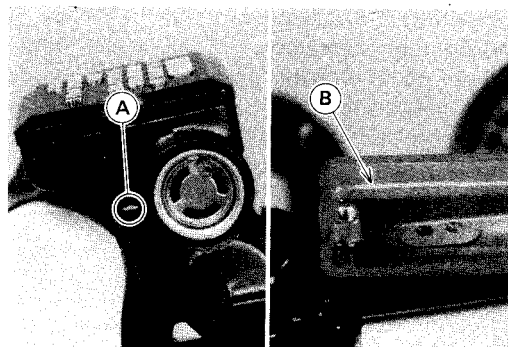

⚠ WARNING

Change the fluid in the clutch line completely if the fluid must be refilled but the type and brand of the fluid that already is in the reservoir are unidentified.

After changing the fluid, use only the same type and brand of fluid thereafter. Mixing different types and brands the clutch to be ineffective. It may also cause the rubber clutch parts to deteriorate.

Recommended Clutch Fluid

- Grade: D.O.T.4 Heavy Duty Brake Fluid
- Brand: Castrol Girling-Universal
- Castrol GT (LMA)
- Castrol Disc Brake Fluid
- Castrol Shock Premium Heavy Duty

NOTE

- Since the clutch fluid is the same as the brake fluid refer to Brake Fluid Section in Brakes for further details.

Clutch Fluid Changing

- Remove the reservoir cap, and remove the rubber cap on the bleed valve.
- Attach a clear plastic hose to the bleed valve on the clutch slave cylinder, and run the other end of the hose into a container.
- Fill the reservoir with fresh fluid.
- Check the clutch fluid as follows.
 - Open the bleed valve. [A]
 - Squeeze the clutch lever and hold it. [B]
 - Close the bleed valve. [C]
 - Release the clutch lever. [D]
- Repeat this operation until fresh fluid comes out from the plastic hose or the color of the fluid changes.
- Check the fluid level in the reservoir often, replenishing it as necessary.

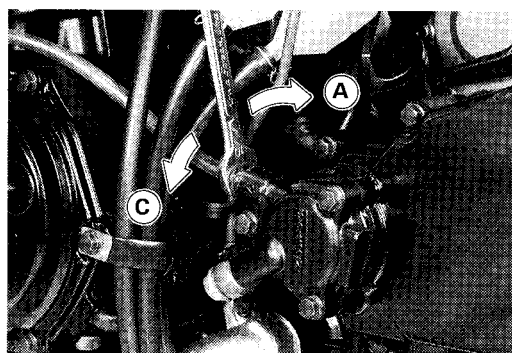

NOTE

- If the fluid in the reservoir runs completely out any time during fluid changing, the bleeding operation must be done over again from the beginning since air will have entered the line.

⚠ WARNING

Do not mix two brands of fluid.

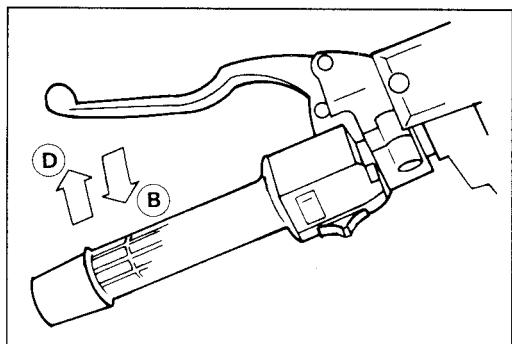

5-6 CLUTCH

Bleeding the Clutch Line

- With the reservoir cap off, slowly pump the clutch lever several times until no air bubbles can be seen rising up through the fluid from the holes at the bottom of the reservoir. This bleeds the air from the master cylinder end of the line.

NOTE

- Tap the clutch hose lightly going from the lower end to the upper end and bleed the air off at the reservoir.
- Attach a clear plastic hose to the bleed valve on the clutch slave cylinder, and run the other end of the hose into a container.
- Bleed the clutch line as follows:
 - Pump the clutch lever a few times until it becomes hard and then hold it squeezed. [A]
 - Quickly open and close the bleed valve. [B]
 - Release the clutch lever. [C]
 - Repeat this operation until no more air can be seen coming out in to the plastic hose.
 - Check the fluid level in the reservoir often, replenishing it as necessary.

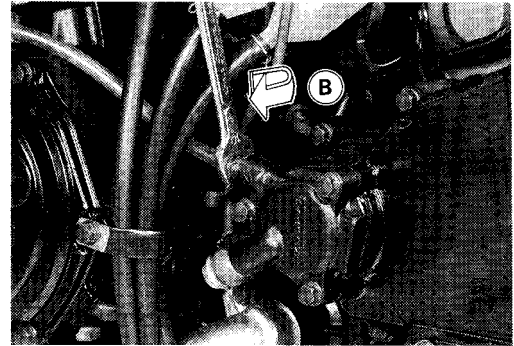
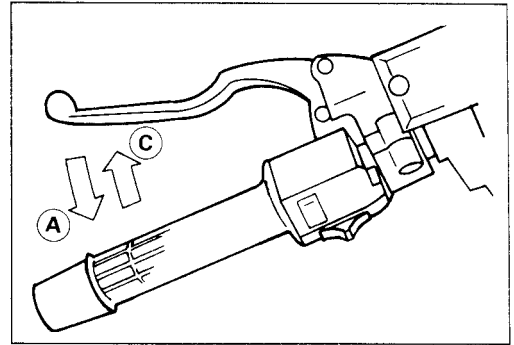

NOTE

- If the fluid in the reservoir runs completely out any time during bleeding, the bleeding operation must be done over again from the beginning since air will have entered the line.

▲WARNING

Do not mix two brands of fluid.

Master Cylinder

Installation

- When installing the clutch master cylinder, be careful of following .
- The master cylinder clamp with the arrow on it pointing upwards. [B]
- Tighten the upper clamp bolt first [A], and then the lower clamp bolt.

Torque – Upper and Lower Clamp Bolt: 11 N-m(1.1 kg-m, 95 in-lb)

- Replace the aluminum washer on each side of the clutch hose fitting with a new one.
- Tighten the banjo Bolt.

Torque – Banjo Bolt: 25 N-m(2.5 kg-m, 18.0 ft-lb)

- Perform the following after installing the master cylinder.
 - Bleed for clutch line
 - Check for clutch operation
 - Check for fluid leakage

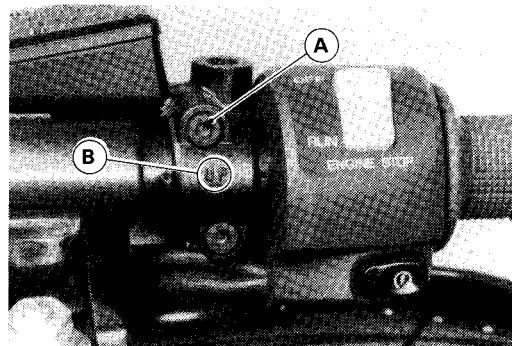

Disassembly

- Remove the following.
 - Clutch Lever
 - Dust Cover
 - Primary Cup [A]
 - Secondary Cup [B]
 - Piston [C]
 - Circlip [D]
 - Spring

NOTE

- Do not remove the secondary cup from the piston.

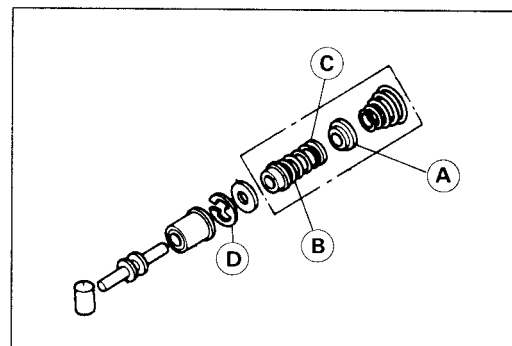

Assembly

- Clean the disassembled parts with clutch fluid and apply clutch fluid to the inner wall of the cylinder.

CAUTION

Take care not to scratch the piston or the inner wall of the cylinder.

Inspection

- Check the following for wear, damage, cracks, or deterioration:
 - Cylinder Inner Wall and Piston
 - Primary and Secondary Cups
 - Dust Cover
 - Spring
- Check that the relief and supply ports on the cylinder are not plugged.

5-8 CLUTCH

Clutch Slave Cylinder

Removal

- Remove the following
 - Banjo Bolt [A]
 - Mounting Bolts [B]
- Slave Cylinder [C]

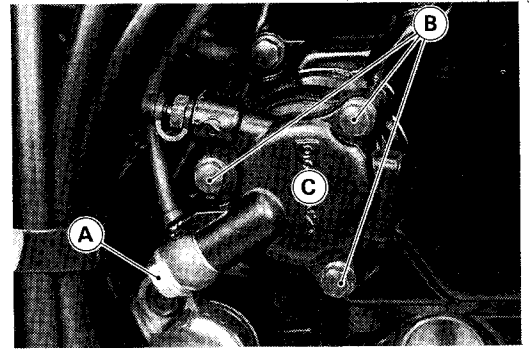

CAUTION

Immediately wash away any brake fluid that spills. It may damage painted surfaces.

- Perform the following if the clutch slave cylinder is to be removed but not disassembled.

CAUTION

If the clutch slave cylinder is removed and left alone, the piston will be pushed out by the spring and the clutch fluid will drain out.

- Remove the clutch slave cylinder from the engine with the hose and push the piston into the cylinder as far as it will go.
- Squeeze the clutch lever slowly and hold it with a band.

NOTE

- Holding the clutch lever keeps the piston from coming out.

Installation

- Note the following.
 - Replace the aluminum washers on each side of the clutch hose fitting with new ones.
 - Tighten the banjo bolt to the specified torque (see Exploded View).
 - Replace the spacer of the clutch slave cylinder with bolts of the slave cylinder with new one.
 - Apply non-permanent locking agent to the two short bolts of the slave cylinder mounting bolts.
 - Check the fluid level in the master cylinder reservoir, and bleed the air in the clutch line.
 - Check the clutch operation.

Disassembly

- Using compressed air, remove the piston.
 - Cover the cylinder opening with a clean, heavy cloth. [B]
 - Face the opening downwards.
 - Remove the piston by lightly applying compressed air [A] to where the clutch line fits into the slave cylinder.

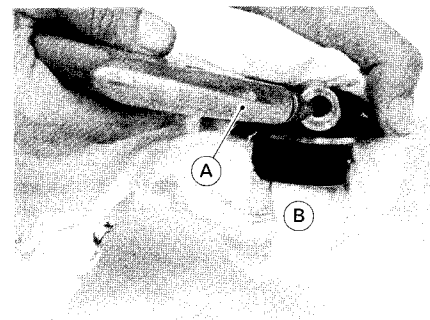

CAUTION

If the fluid seal is removed from the piston, replace the seal with a new one. Removal would damage the seal.

⚠ WARNING

To avoid serious injury never place your fingers or palm in front of the cylinder opening. If you apply high compressed air to the cylinder, the piston may injure your hand or fingers.

Assembly

- Do the following.
- Apply clutch fluid to the outside of the piston and the fluid seal.
- Install the fluid seal as shown in the figure.

Cylinder [A] Fluid Seal [C]
Piston [B] Spring [D]

CAUTION

Replace the fluid seal with a new one if it was removed from the piston.

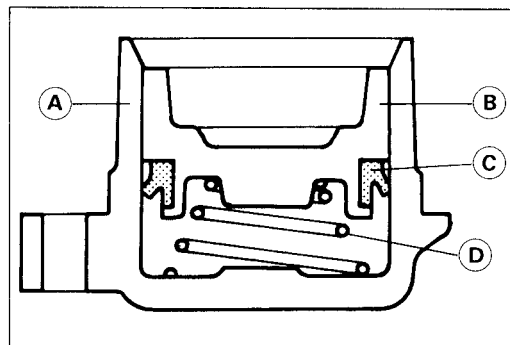

5-10 CLUTCH

Clutch

Removal

- Remove the following.
 - Lower Fairing
 - Clutch Cover [A]
 - Clutch Cover Bolt [B]

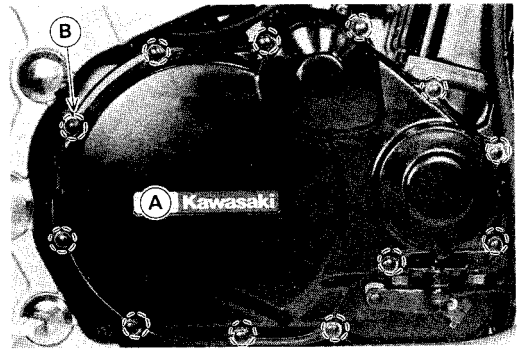

- Clutch Spring Bolts [A]
- Clutch Springs
- Clutch Spring Plate (with thrust bearing and pusher) [B]

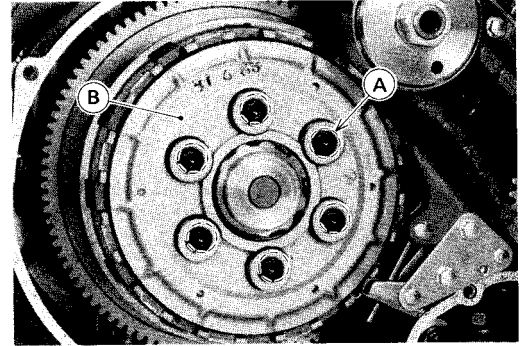

- Friction Plates, Steel Plates
- Clutch Hub

- Holding the clutch hub, remove the nut [B].

Special Tool – Clutch Holder: 57001-1243 [A]

NOTE

- When removing the clutch housing, remove the alternator drive chain tensioner for easy handling (see Crankshaft/Transmission chapter).

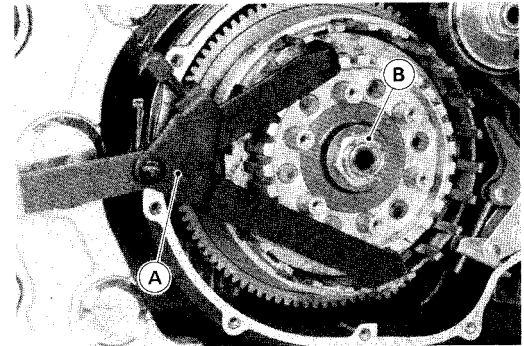

- Sleeve [A]
- Clutch Housing [B]

- Using the two 6 mm bolts, pull out the sleeve.

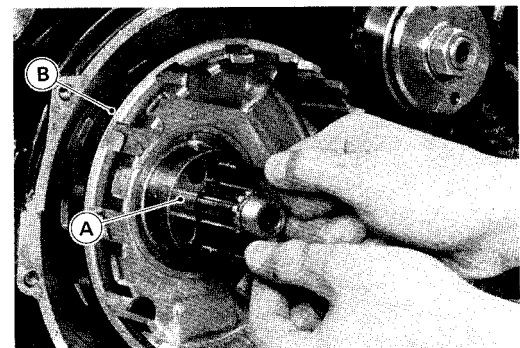

- To disassemble the clutch hub, remove the following.
 - Circlip
- Press [C] in the damper spring plate [A], and remove the circlip [B].

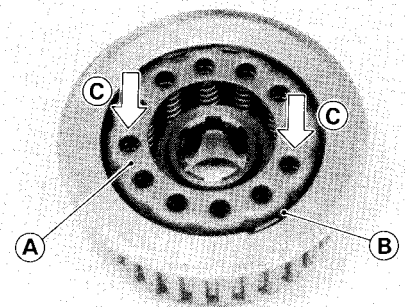

Installation

- Installation is the reverse of removal. Note the following.
- Discard the used clutch hub nut, and install a new nut.

CAUTION

If new dry friction plates and steel plates are installed, apply engine oil to the surfaces of each plate to avoid clutch plate seizure.

- Install the last friction plate [A], fitting the tangs in the groove on the housing as shown.

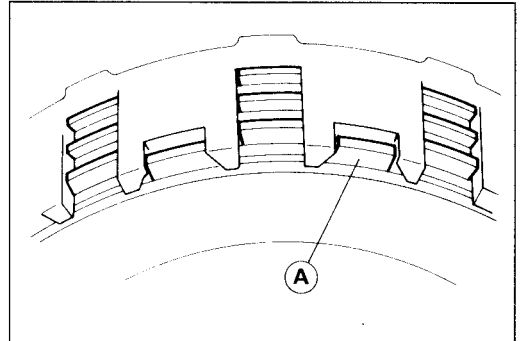

- Install the alternator drive chain tensioner, if it was removed (see Crankshaft/Transmission chapter).
 - Tighten the clutch hub nut.
- Torque – Clutch Hub Nut: 130 N-m (13.5kg-m, 98 ft-lb)**
- Install the clutch plates and steel plates, starting with a friction plate and alternating them.

- Before installing the clutch spring plate, squeeze the clutch lever slowly and hold it with a band while pushing the spring plate pusher into the clutch hub.

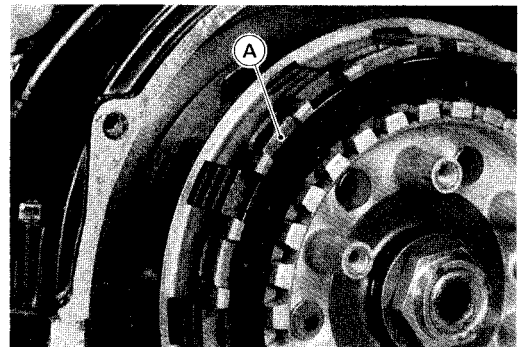

- Apply molybdenum disulfide grease to the push rod end. [A].

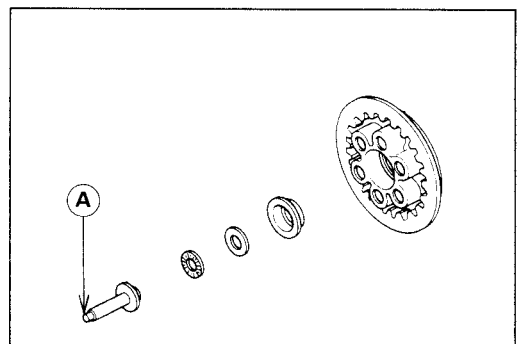

5-12 CLUTCH

- Tighten the clutch spring bolts.

Torque – Clutch Spring Bolts : 11 N-m(1.1 kg-m, 95 in-lb)

- Apply silicone sealant[A] with 5 mm long[C] to the crankcase halves mating surface[B] on the front and rear sides of the cover mount.

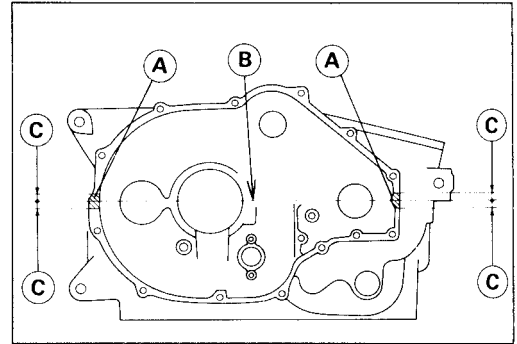

- Apply a non-permanent locking agent to the 4 Clutch Cover Bolts [A].

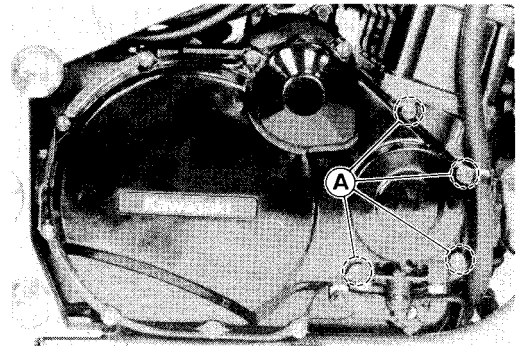

Friction Plate Wear

- ★ If any friction plate [A] thickness is less than the service limit, replace the friction plates as a set.

Friction Plate Thickness

Standard: 2.7 – 3.0 mm

Service Limit: 2.5 mm

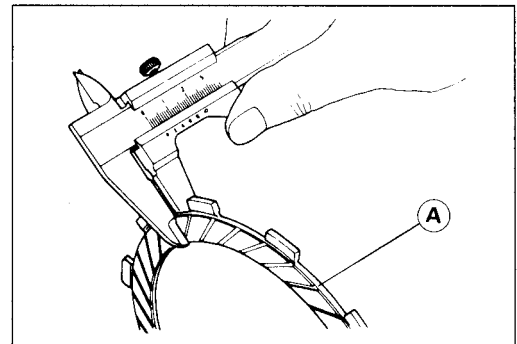

Friction and Steel Plate Warp

- ★ If any plate is warped over the service limit, replace the plates as a set.

Friction and Steel Plate Warp

Standard: less than 0.2 mm

Service Limit: 0.3 mm

[A] Friction or Steel Plate [C] Surface Plate

[B] Thickness Gauge

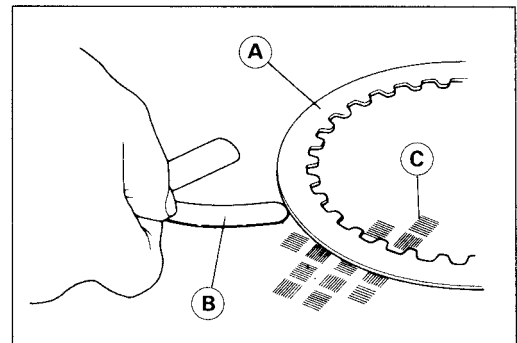

Clutch Spring Free Length Measurement

★ If any of the spring [A] is shorter than the service limit, it must be replaced.

Clutch Spring Free Length

Standard: 46.3 mm

Service Limit: 42.7 mm

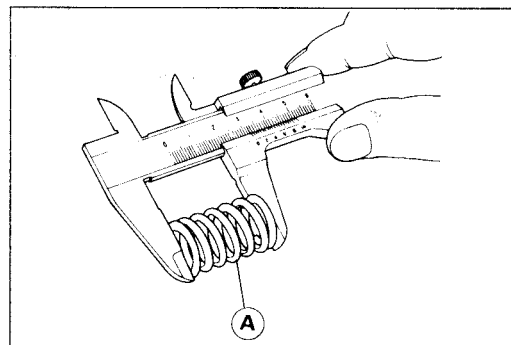

Cam Damper Inspection

● Visually inspect the damper cam [A], damper springs [C], and cam follower [B].

★ Replace any part that appears damaged.

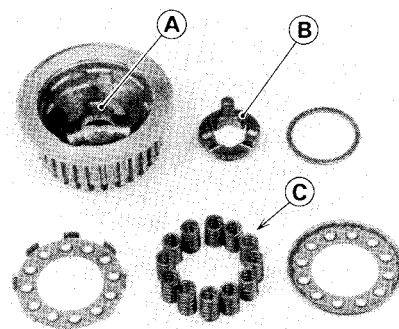

Engine Lubrication System

Table of Contents

Exploded View	6-2
Engine Oil Flow Chart.....	6-4
Specifications	6-5
Engine Oil and Oil Filter.....	6-6
Oil Level Inspection	6-6
Engine Oil Change	6-6
Oil Filter Change	6-7
Oil Pan	6-8
Removal	6-8
Installation	6-8
Oil Pump and Relief Valve.....	6-10
Oil Pump and Relief Valve Removal	6-10
Oil Pump and Relief Valve Installation.....	6-10
Oil Cooler	6-12
Removal	6-12
Installation.....	6-12
Inspection	6-13
Oil Pressure Measurement.....	6-14
Oil Pressure Measurement.....	6-14

6-2 ENGINE LUBRICATION SYSTEM

Exploded View

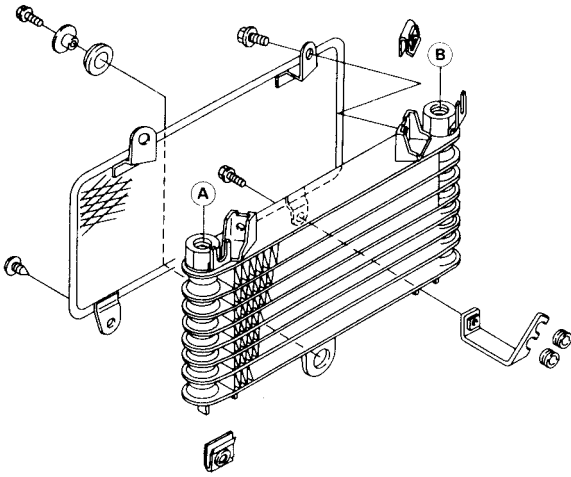

- 1. Oil Pressure Switch
- 2. Small hole side

L: Apply non-permanent
SS: Apply silicone sealant

- T1: 12 N-m (1.2 kg-m, 104 in-lb)
- T2: 15 N-m (1.5 kg-m, 11.0 ft-lb)
- T3: 18 N-m (1.8 kg-m, 13.0 ft-lb)
- T4: 20 N-m (2.0 kg-m, 14.5 ft-lb)
- T5: 25 N-m (2.5 kg-m, 18.0 ft-lb)
- T6: 29 N-m (3.0 kg-m, 22 ft-lb)
- T7: 34 N-m (3.5 kg-m, 25 ft-lb)

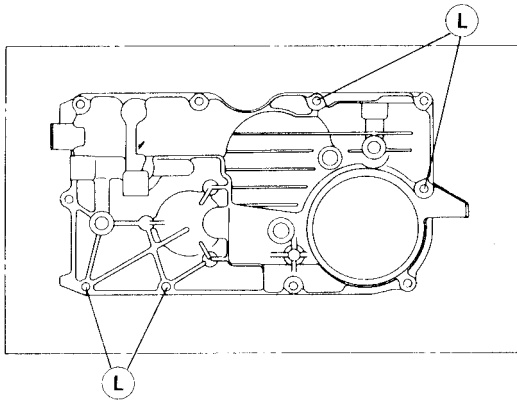
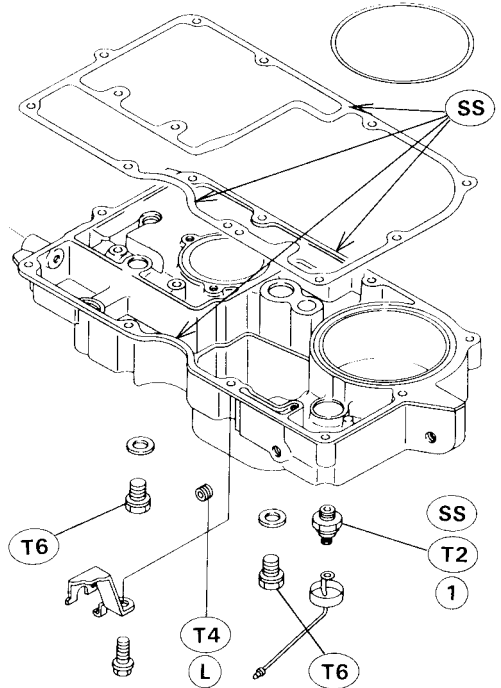
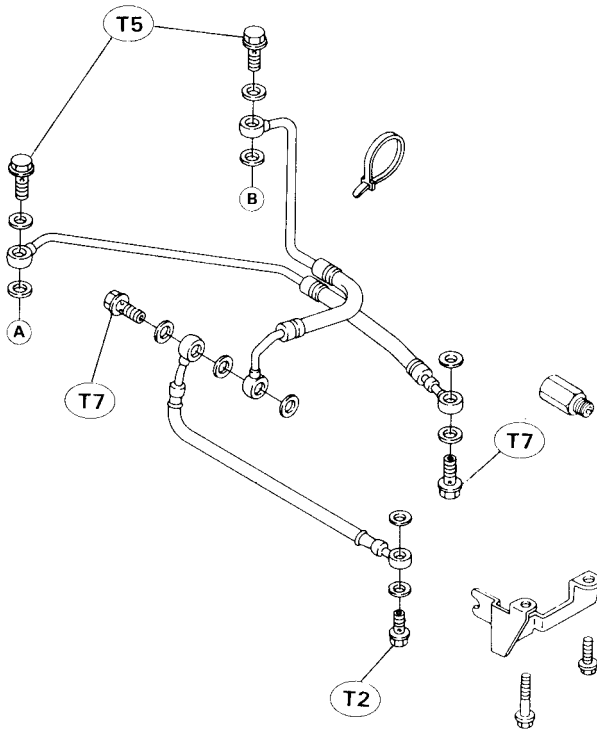

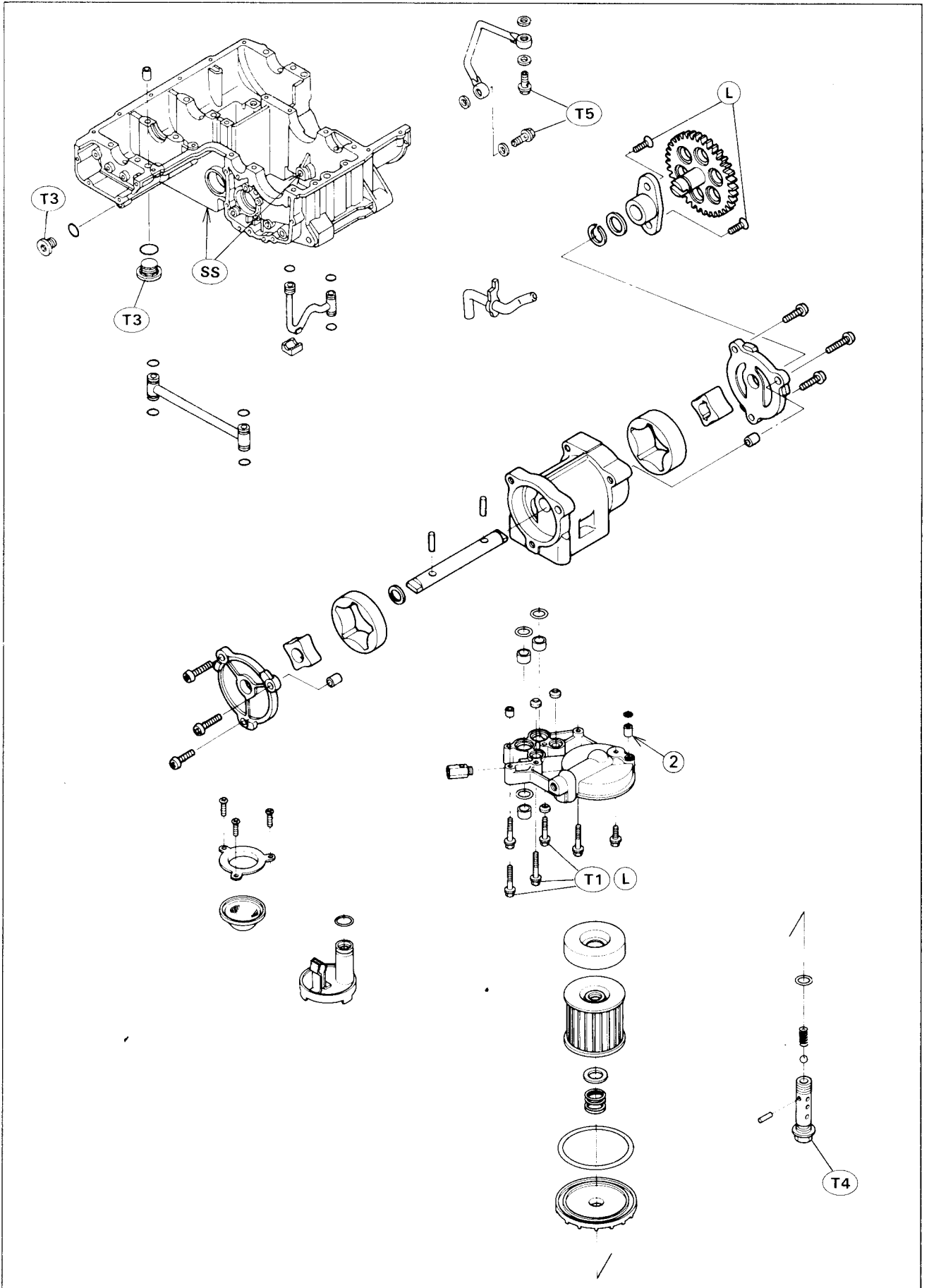

6-4 ENGINE LUBRICATION SYSTEM

Engine Oil Flow Chart

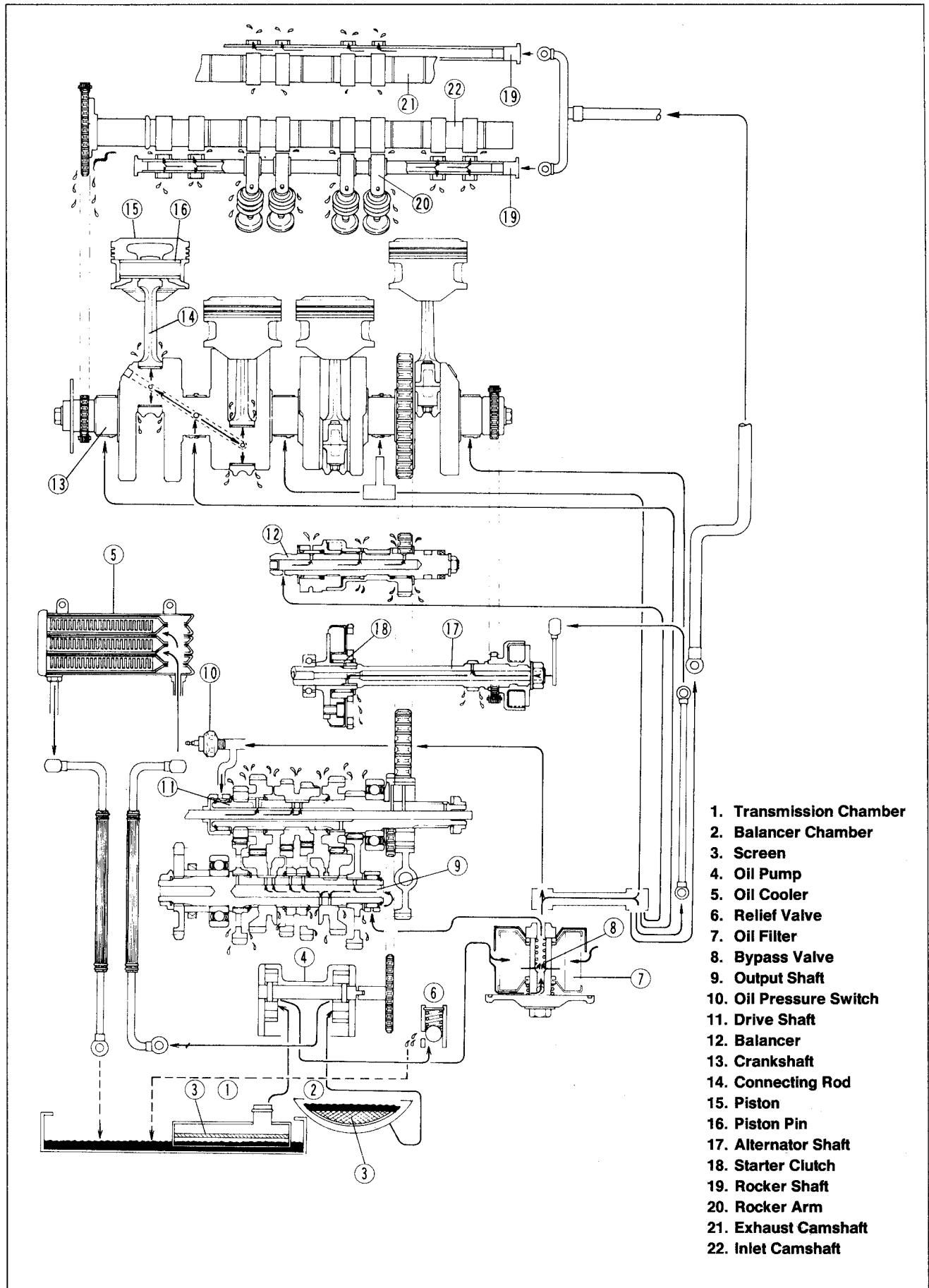

Specifications

Item	Standard
Engine Oil: Grade Viscosity Capacity	SE, SF, or SG class SAE 10W-40, 10W-50, 20W-40, or 20W-50 3.2L (when filter is not removed) 3.5L (when filter is removed)
Oil Pressure Measurement: Oil pressure @4,000 r/min(rpm), oil temp. 90°C(194°F)	196 ~ 294 kPa(2.0 ~ 3.0 kg/cm ² , 28 ~ 43 psi)

Special Tool – Kawasaki Bond (Silicone Sealant): 56019-120

6-6 ENGINE LUBRICATION SYSTEM

Engine Oil and Oil Filter

⚠ WARNING

Motorcycle operation with insufficient, deteriorated, or contaminated engine oil will cause accelerated wear and may result in engine or transmission seizure, accident, and injury.

Oil Level Inspection

- Check the engine oil level between the upper [A] and lower [B] level in the gauge.

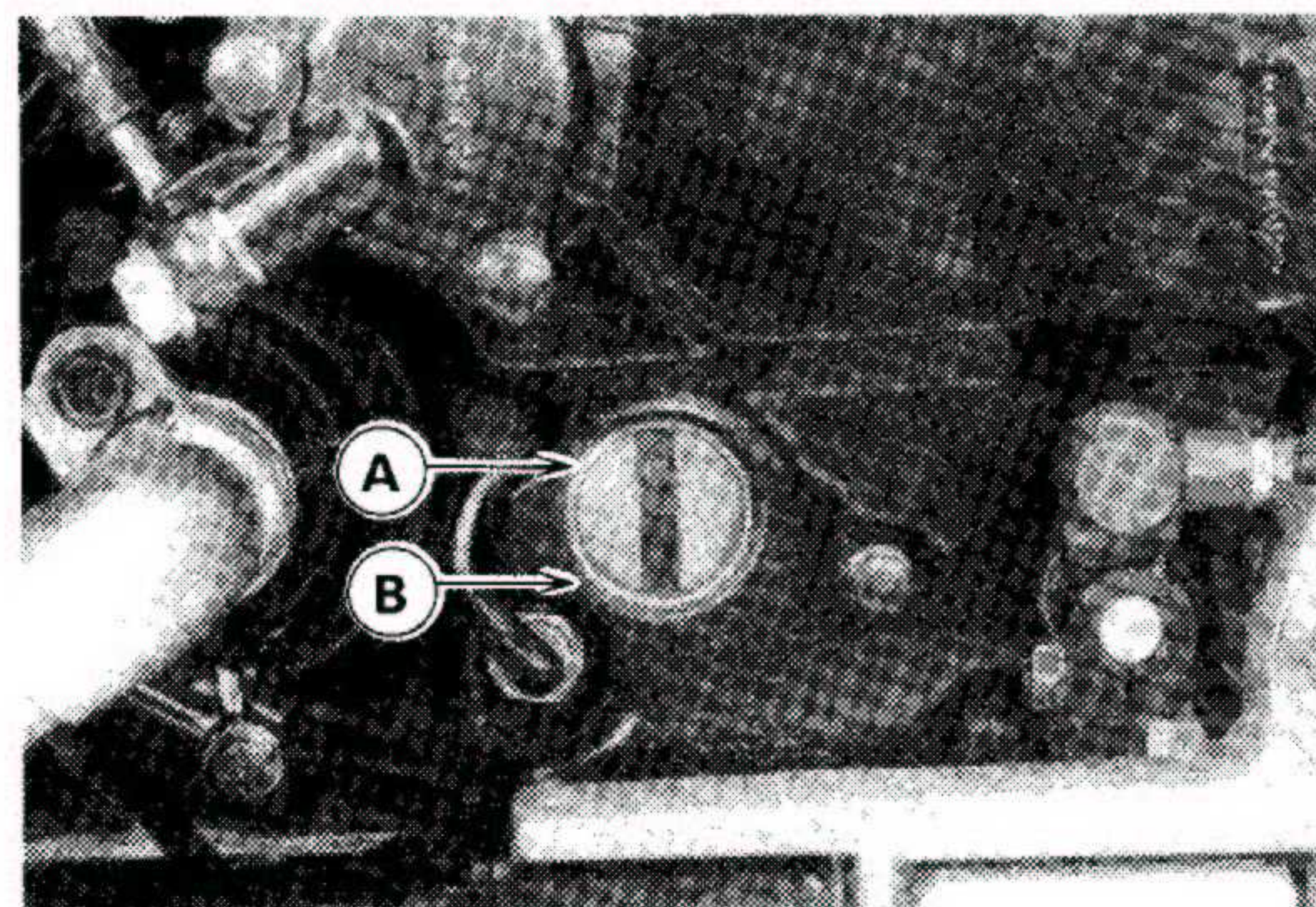

NOTE

- Situate the motorcycle so that it is perpendicular to the ground.
- If the motorcycle has just been used, wait several minutes for all the oil to drain down.
- If the oil has just been changed, start the engine and run it for several minutes at idle speed. This fills the oil filter with oil. Stop the engine, then wait several minutes until the oil settles.

CAUTION

Racing the engine before the oil reaches every part can cause engine seizure.

If the engine oil gets extremely low or if the oil pump or oil passages clog up or otherwise do not function properly, the oil pressure warning light will light. If this light stays on when the engine is running above idle speed, stop the engine immediately and find the cause.

Engine Oil Change

- Set the motorcycle up on its center stand after warming up the engine.
- Remove the lower fairing.
- Remove the engine drain plugs [A] to drain the oil.
- The oil in the filter can be drained by removing the filter mounting bolts [B] and raking off the filter from the bolt.
- ★ Replace the drain plug gasket with a new one if it is damaged.
- Tighten the drain plugs to the specified torque (see Exploded View).
- Tighten the oil filter mounting bolt to the specified torque (see Exploded View).
- Pour in the specified type and amount of oil.

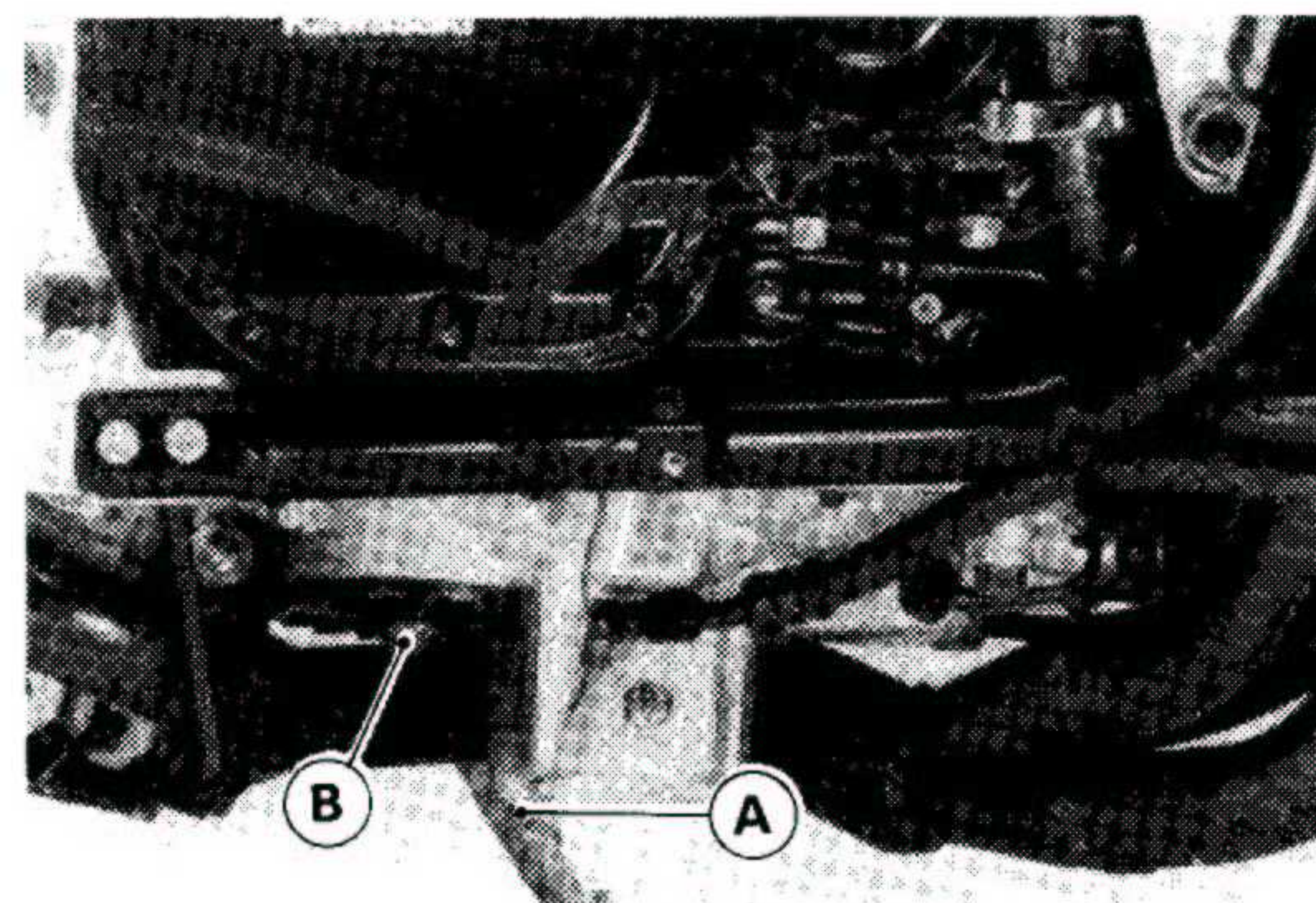

Engine Oil

- Grade SE, SF, or SG class
- Viscosity: SAE 10W40, 10W50, 20W50, 20W40, 20W50
- Amount: 3.5L (engine is completely dry)
3.5L (filter is removed)
3.2L (filter is not removed)

Oil Filter Change

- Drain the engine oil.
- Disconnect the oil pressure switch lead and Remove the oil filter mounting bolt and take off the filter assembly.

NOTE

○ The oil filter bypass valve is assembled in the mounting bolt.

- | | |
|------------------|-----------|
| A. Mounting Bolt | E. Spring |
| B. O-ring | F. Washer |
| C. Filter Cover | G. Filter |
| D. Oil Fence | |

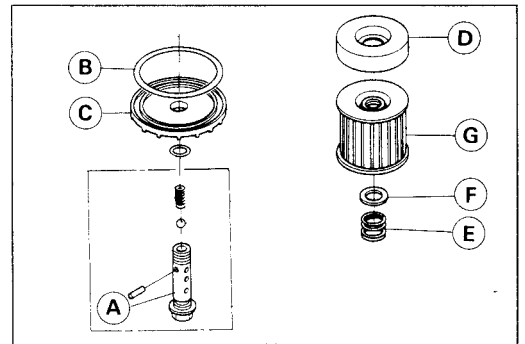

- When installing the oil filter, be careful of the following.
- Apply oil to the mounting bolt, turn the filter or the mounting bolt to work the filter into place. Be careful that the filter grommets do not slip out of place.
- Tighten the filter mounting bolt.

Torque – Filter Mounting Bolts: 20 N-m (2.0 kg-m, 14.5 ft-lb)

- ★ Replace the O-rings with new ones if they are damaged.
- Pour in the specified type and amount of oil.

- Be careful not to pinch the oil pressure switch lead [A] between the oil filter cover [B] and the oil pan.
- The oil pressure switch lead must be installed to the correct position to keep away from the mufflers.

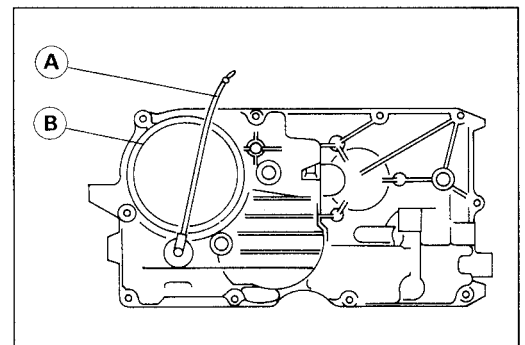

6-8 ENGINE LUBRICATION SYSTEM

Oil Pan

Removal

- Remove the following
 - Fairings
 - Engine Oil (drain)
 - Coolant (drain)
 - Radiator
 - Oil Cooler
 - Mufflers
 - Oil Filter
 - Oil Pipe [A]
 - Oil Hose Banjo Bolts [B]
- Remove the oil pan bolts and take off the oil pan,

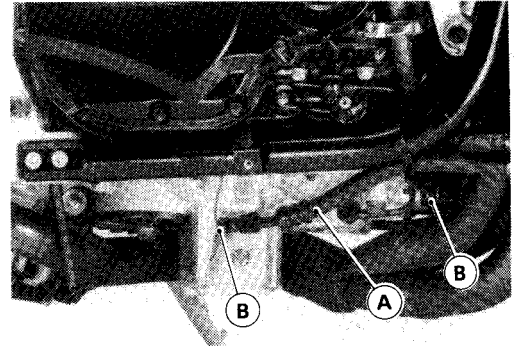

Installation

- Installation is the reverse of removal. Note the following.
- Apply a silicone sealant to the illustrated area [A], threads if the oil pressure switch, and tighten them.

Torque – Oil Pressure Switch: 15 N-m(1.5 kg-m, 11.0 ft-lb)

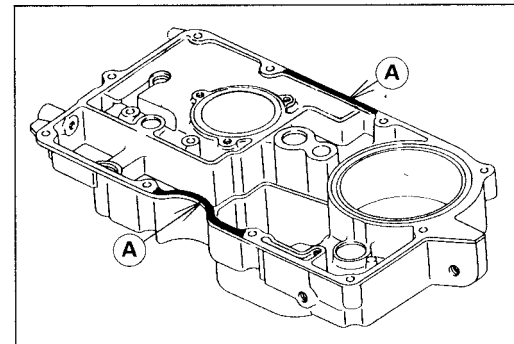
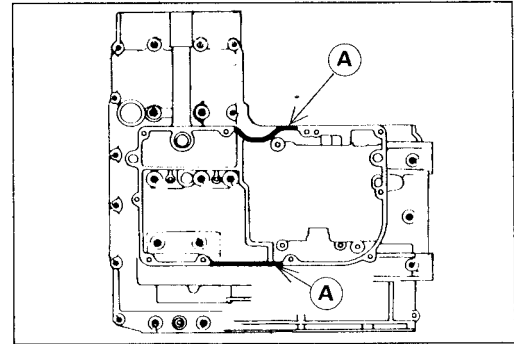

- Replace the gasket with a new one.
- Replace the O-rings[A] with new ones if they are damaged.
- The outlet side O-ring[B] between the oil pan and oil pump bracket must be installed so that flat side faces the bracket.

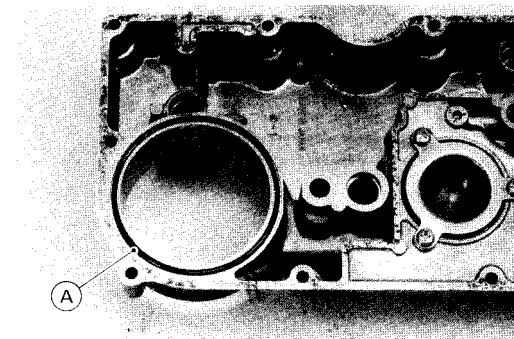
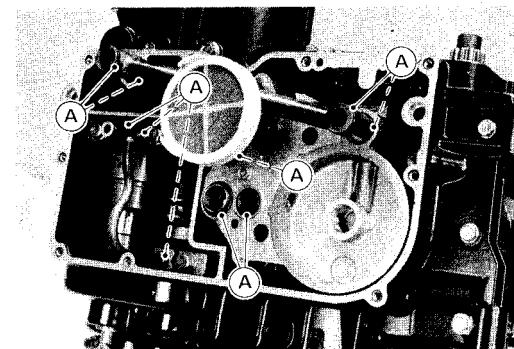

- Apply a non-permanent locking agent to the threads of the four oil pan bolts which are indicated by the triangular marks[A].

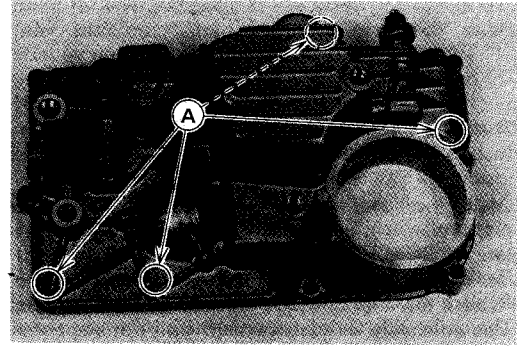

6-10 ENGINE LUBRICATION SYSTEM

Oil Pump and Relief Valve

Oil Pump and Relief Valve Removal

- Remove the following.
 - Oil Pan
 - Oil Screen
 - Oil Pipe
 - Oil Pump Bracket Bolts
- Pull out the bracket and pump assembly.

NOTE

○ Remove the pickup coil cover, and turn the crankshaft until the catches [A] of the pump shaft ends are vertical.

- Remove the oil pump [A].
- Unscrew the relief valve [B].

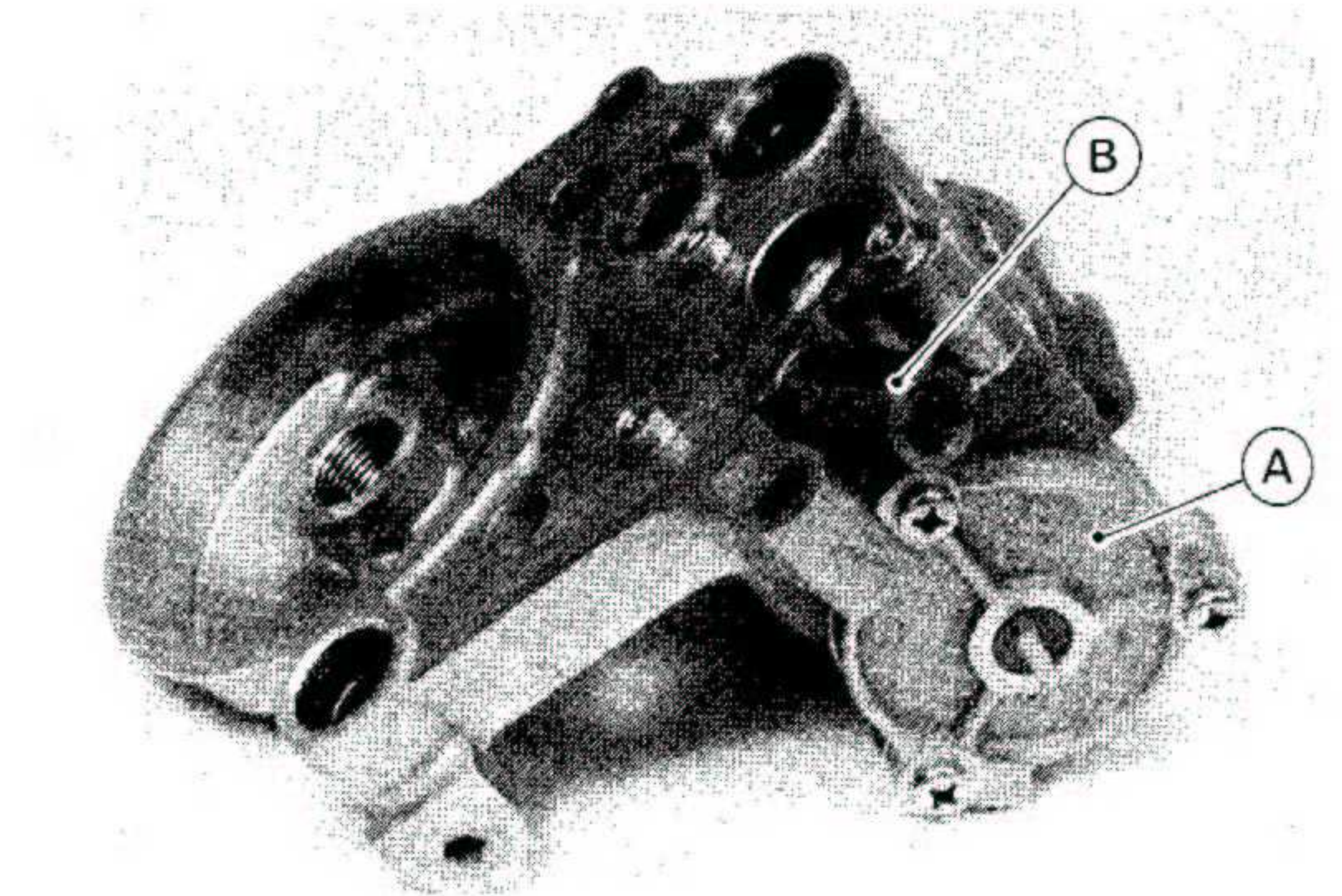
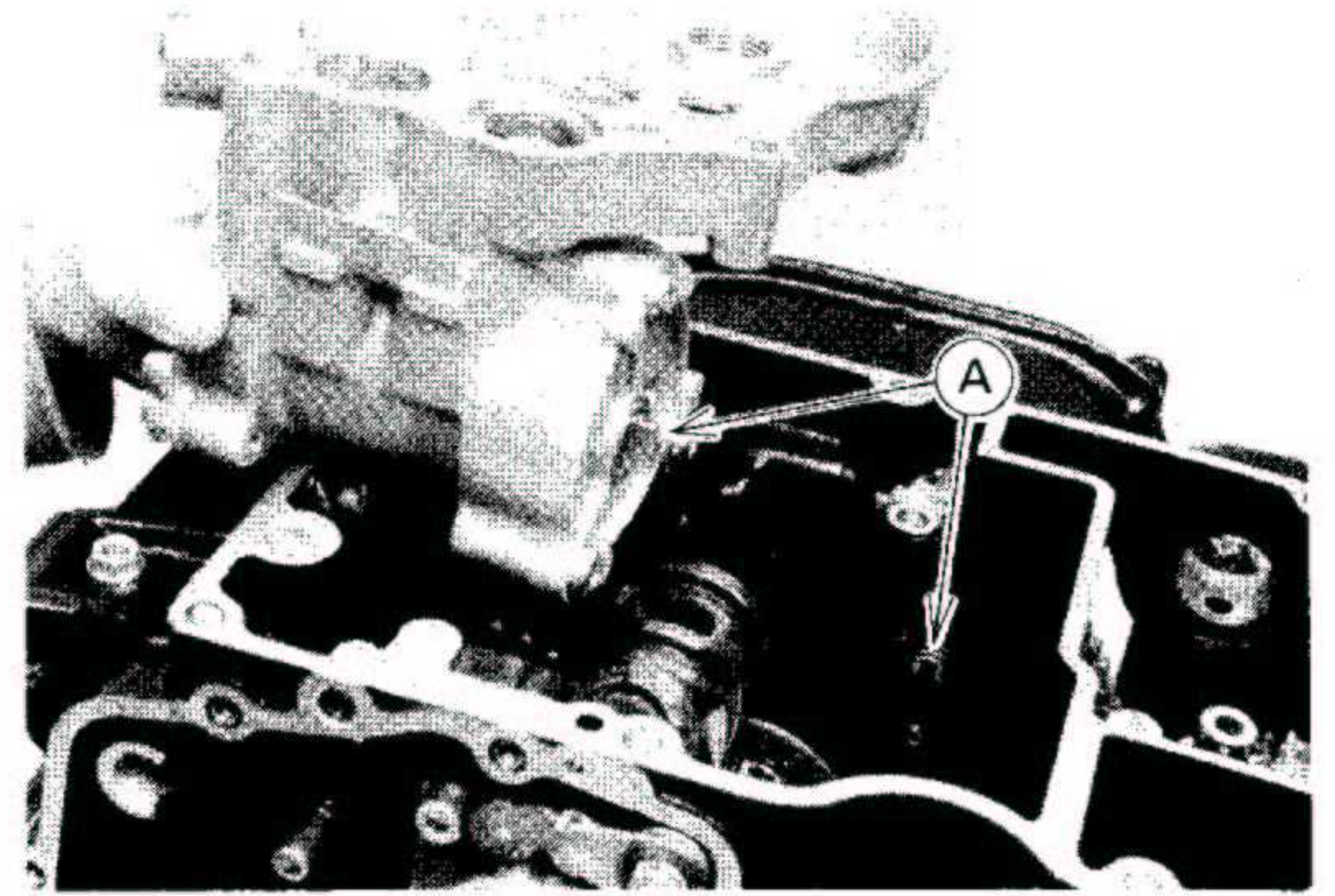

Oil Pump and Relief Valve Installation

- Fill the pump with engine oil before installation.
- Check that the collars [A] and O-rings [B] are in a place. The outlet side O-rings must be installed so that the flat side faces the bracket.

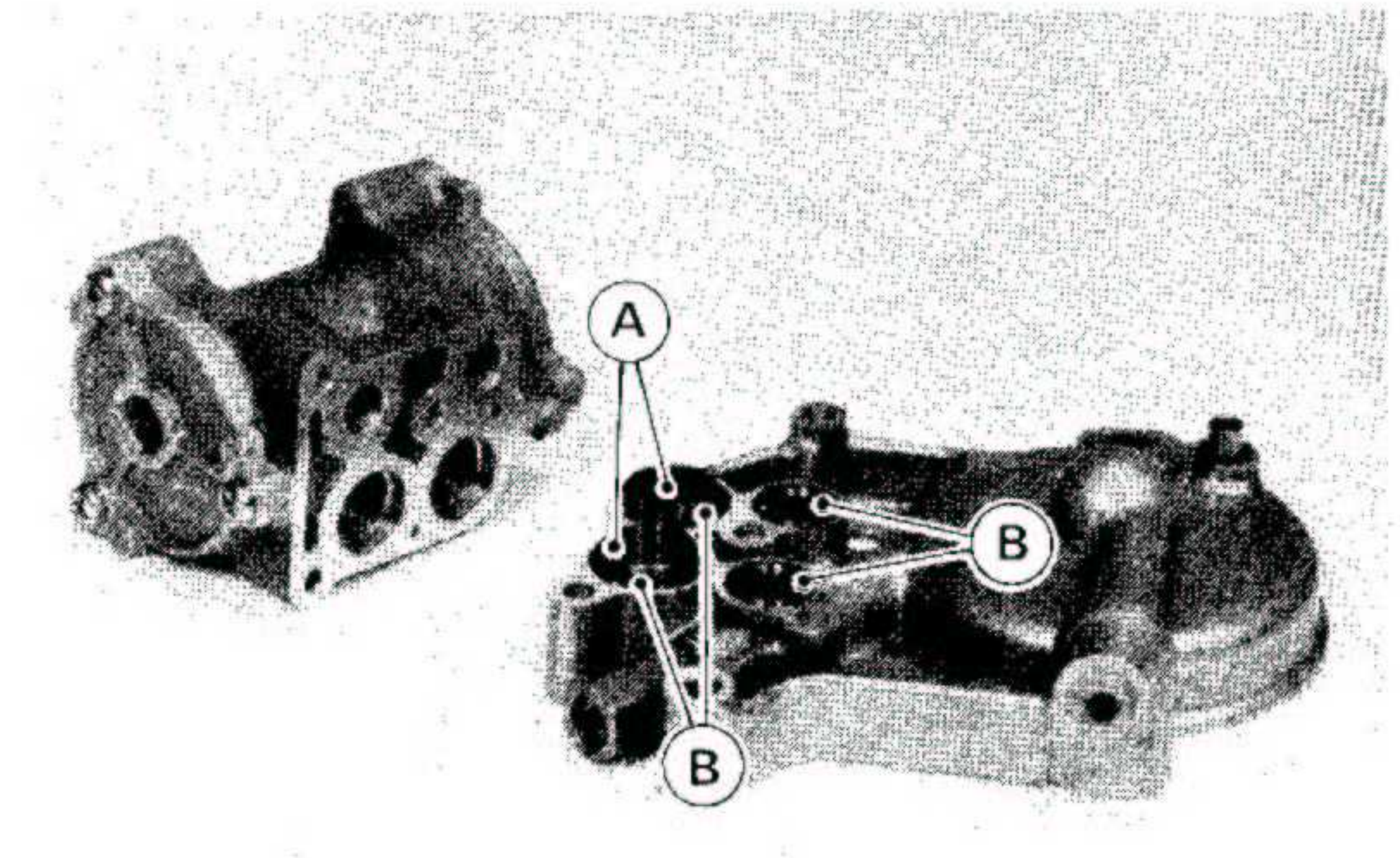

- Apply a non-permanent locking agent to the following and tighten them.
 - Relief Valve
 - Oil Pump Mounting Bolts

Torque – Oil Pump Mounting Bolts: 12 N-m (1.2kg-m, 104 in-lb)

CAUTION

Do not over-apply a non-permanent locking agent to the threads. This may block the oil passage.

- Check that the knock pin [A], nozzle, and O-ring [C] are in place. The small hole of the nozzle [B] must face the bracket.

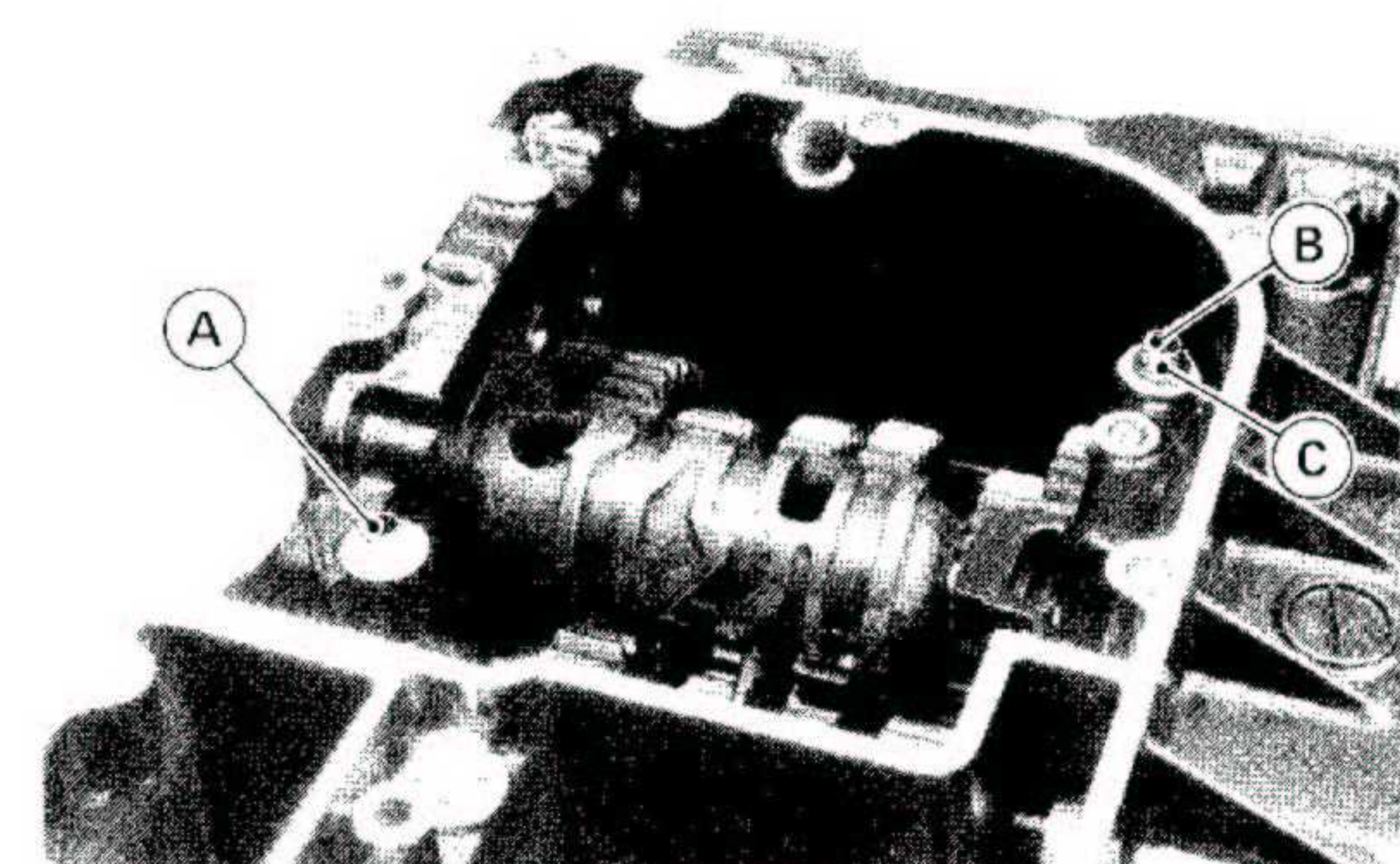

ENGINE LUBRICATION SYSTEM 6-11

- Check that the oil pump shaft catches [A] of both components are vertical.

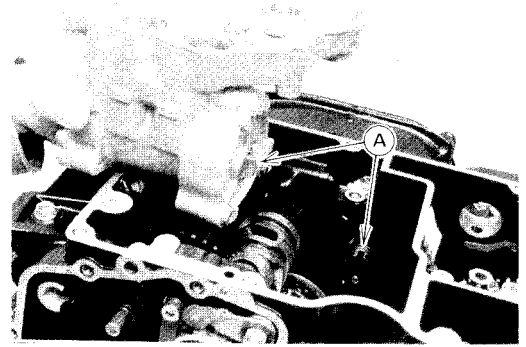

- Before installing the oil pump, be sure the shaft and rotors turn freely.
 - [A] Thinner Rotors
 - [B] Thicker Rotors

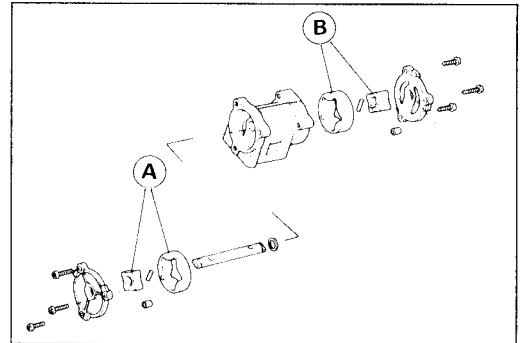

6-12 ENGINE LUBRICATION SYSTEM

Oil Cooler

Removal

- Remove the following
 - Upper and Lower Fairings
 - Engine Oil (drain)
 - Oil Hose Banjo Bolts (cooler side)
 - Oil Cooler Mounting Bolts [A]
 - Oil Screen Mounting Bolt [B]

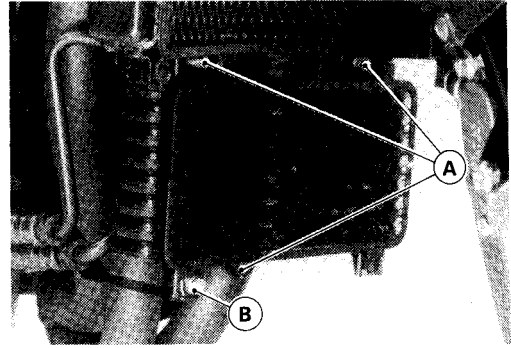

- To remove the oil cooler hoses, remove the mufflers.

Installation

- Installation is the reverse of removal. Note the following.
- Replace the washer in each side of the oil hose fitting with a new one.
- Install the oil hose fitting in the correct position.
 - A. Oil Cooler
 - B. Oil Hose Bracket
 - C. Oil Pan
 - D. Projection
 - E. Damper

Torque – Oil Hose Banjo Bolts

- (8 mm): 15 N-m (1.5 kg-m, 11.0 ft-lb)
- (14 mm Cooler Side): 25 N-m (2.5 kg-m, 18.0 ft-lb)
- (14 mm Oil Pan Side): 34 N-m (3.5 kg-m, 25 ft-lb)

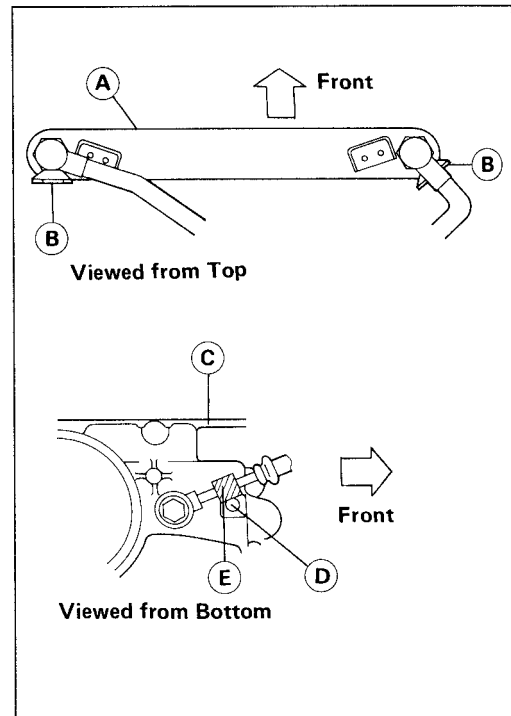

- Install the screen bracket [A] between the oil cooler bracket [B] and the radiator brackets [C].

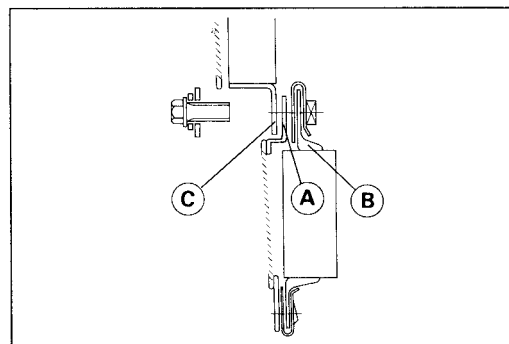

Inspection

- Check the oil cooler.
- ★ If there are obstructions to air flow, remove them.
- ★ If the corrugated fins are deformed, carefully straighten them with blade of a thin screw driver.

CAUTION

Do not tear the cooler tubes while straightening the fins.

- ★ If the air of the cooler core are blocked by unremovable obstructions or irreparably deformed fins, replace the oil cooler.

CAUTION

When cleaning the oil cooler with compressed air, be careful of the following to avoid damage to the fins.

Keep the air nozzle [A] over 0.5 m (20 in.) [B] away from the oil cooler.

Blow air perpendicularly to the cooler core.

Never blow air at an angle against the fins but straight through them in the direction of natural air flow.

Never shake the air nozzle at a right angle against the fins; be sure to move it at a level with the fins.

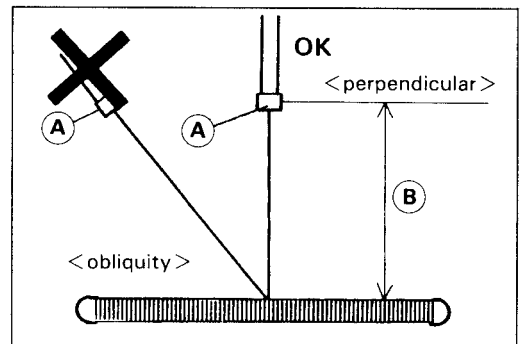

6-14 ENGINE LUBRICATION SYSTEM

Oil Pressure Measurement

Oil Pressure Measurement

- Warm up the engine, and then stop the engine.
- Remove the oil passage plug, and attach the gauge and adapter to the plug hole.

**Special Tool – Oil Pressure Gauge, 10 kg/cm²: 57001-164 [A]
Oil Pressure Gauge Adapter, M18 x 1.5: 57001-1278 [B]**

⚠ WARNING

Take care against burns from hot engine oil that will drain through the oil passage when the plug is removed.

- Start the engine again.
- Run the engine at the specified speed, and read the oil pressure gauge.
- ★ If the oil pressure is significantly below the specification, inspect the oil pump and relief valve.
- ★ If the oil pump and relief valve are not fault, inspect the rest of the lubrication system.

Oil Pressure

**Standard: 196 ~ 294 kPa (2.0 ~ 3.0 kg/cm², 28 ~ 43 psi)
@4,000 r/min(rpm), oil temp. 90°C (194°F)**

- Stop the engine.
- Remove the oil pressure gauge and adapter.
- Install the oil passage plug.

Torque – Oil Passage Plug : 18 N-m(1.8 kg-m, 13.0 ft-lb)

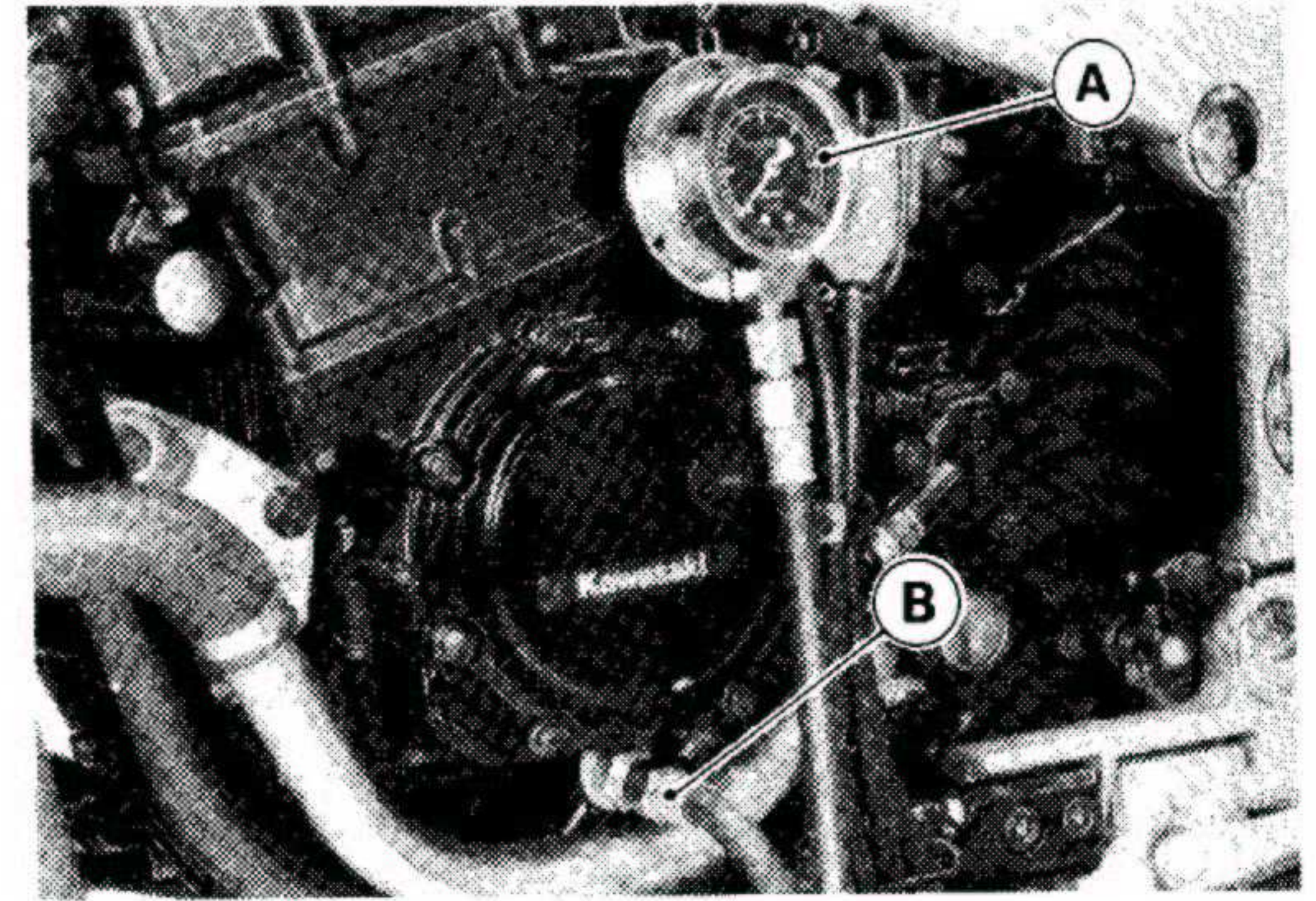

Engine Removal / Installation

Table of Contents

Exploded View	7-2
Engine Removal/Installation.....	7-3
Engine Removal	7-3
Engine Installation	7-4

7-2 ENGINE REMOVAL / INSTALLATION

Exploded View

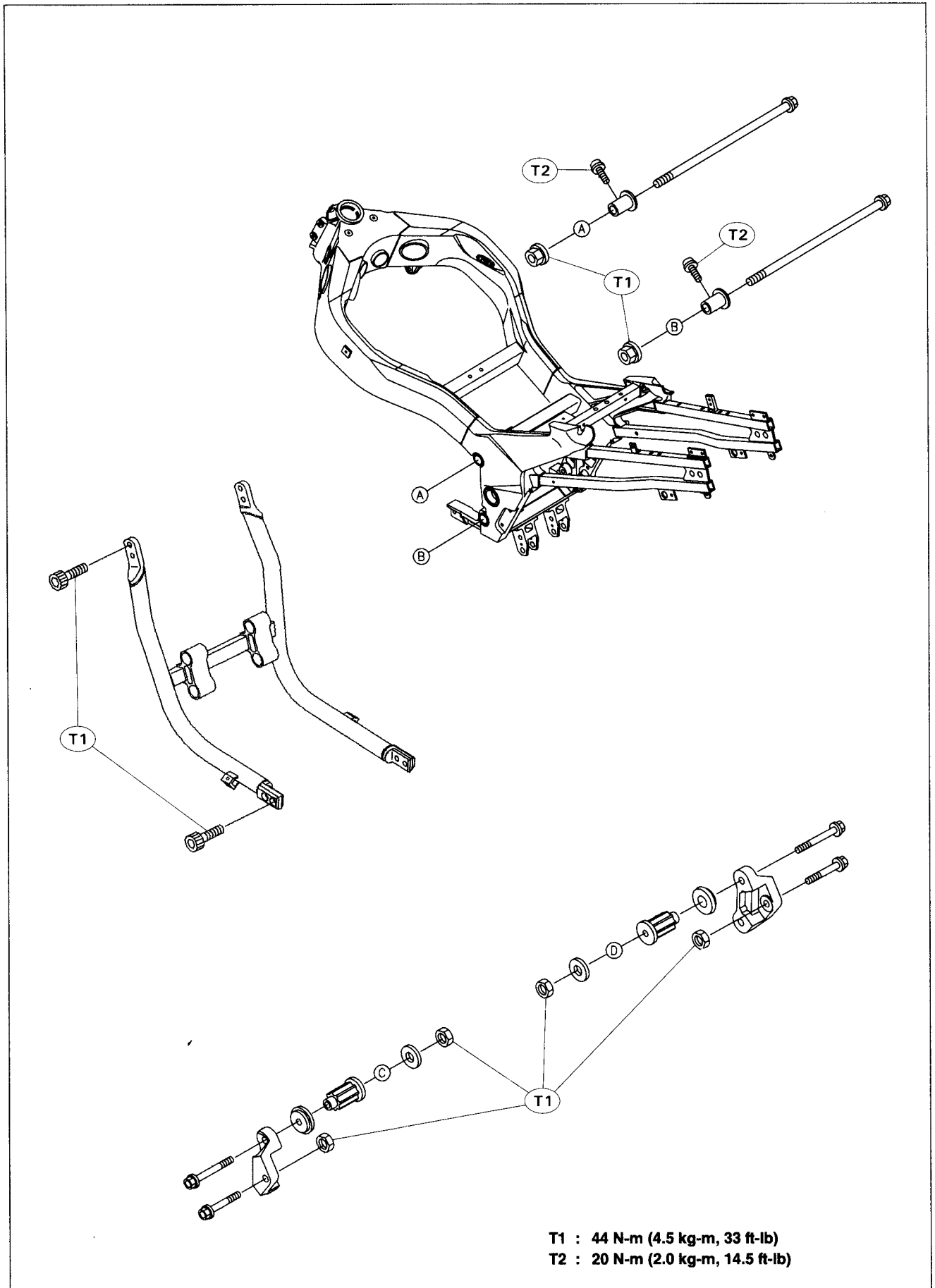

Engine Removal/Installation

Engine Removal

● Remove the following.

- Fairing
- Engine Oil (Drain)
- Coolant (Drain)
- Seat
- Fuel Tank
- Radiator
- Oil Cooler
- Muffler
- Air Cleaner Housing
- Carburetors
- Fuel Pump and Filter
- Clutch Slave Cylinder (see Clutch chapter)
- Engine Sprocket
- Vacuum Switch Valve and Hoses (US model only)
- Baffle Plate

● Disconnect wiring from the engine and free them from the clamps.

- Pickup coil Lead
- Battery Ground Lead [A]
- Starter Motor Lead [B]

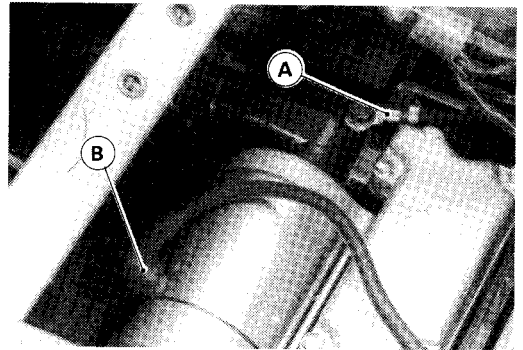

Oil Pressure Switch Wire [A]

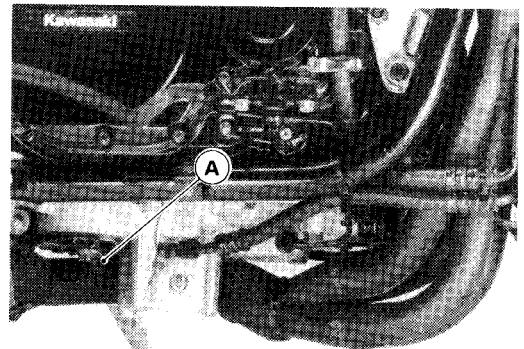

- Neutral Switch Lead [A]
- Side Stand Switch Lead connector [B]
- Alternator Leads [C]

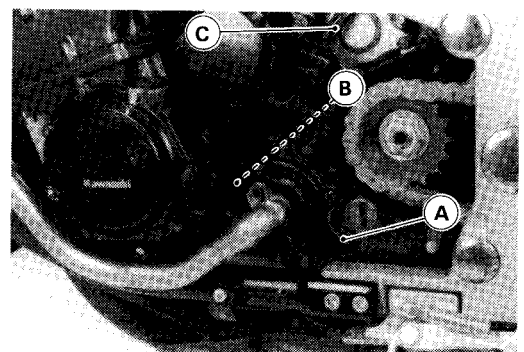

7-4 ENGINE REMOVAL / INSTALLATION

- Support the engine with a stand before take out the rear engine mounting bolts.
- Loosen Allen bolts [A] for supporting collars on the rear upper and lower engine mounting bolts.

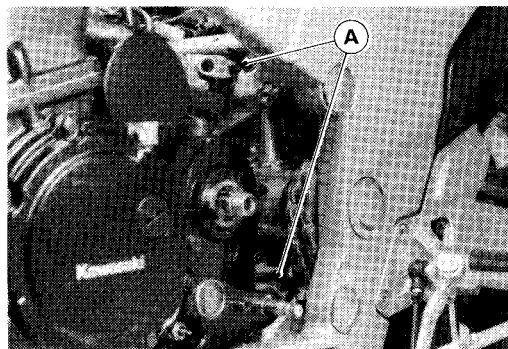

- Remove the front engine mounting bolts [A].
- Remove the down tube Allen bolts [B] and take off the down tubes [C].
- Remove the rear upper and lower engine mounting bolts [D].

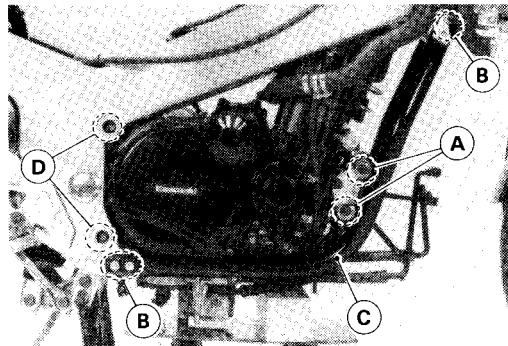

- Now the engine is free from the fasteners.
- Remove the engine by inclining the engine as shown.

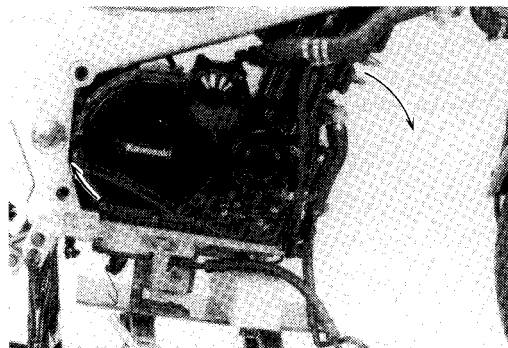

Engine Installation

- Using the jack under the engine, install the engine.
- Install the collar at the left side of the rear engine bolts.
- Torque the following.

Torque – Engine Mounting Bolts : 44 N-m (4.5 kg-m, 33 ft-lb)

- Front Engine Bracket Bolt
- Front Engine Mounting Bolt
- Rear Upper and Lower Engine Mounting Bolt
- Down Tube Allen Bolt

Torque – Rear Upper and Lower Allen Bolts : 20 N-m (2.0 kg-m, 14.5 ft-lb)

- Run the leads, cables and hoses correctly (see Cable, Wire and House Routing in General Information chapter).
- Install the removed parts (see appropriate chapters).
- Adjust:
 - Throttle Cables
 - Choke Cable
 - Drive Chain

Crankshaft / Transmission

Table of Contents

Exploded View	8-2
Specifications	8-5
Crankcase Splitting	8-7
Crankcase Splitting	8-7
Crankcase Assembly	8-8
Crankshaft and Connecting Rods	8-10
Crankshaft Removal.....	8-10
Crankshaft Installation Notes	8-10
Connecting Rod Removal	8-10
Connecting Rod Installation Notes.....	8-10
Connecting Rod Big End Bearing Insert/Crankpin Wear.....	8-12
Crankshaft Main Bearing Insert/Journal Wear	8-13
Crankshaft Side Clearance.....	8-14
Crankshaft Runout.....	8-15
Balancer.....	8-16
Balancer Removal	8-16
Balancer Installation Notes.....	8-16
Damper Inspection	8-17
Needle Bearing Wear	8-17
Alternator Shaft/Starter Motor Clutch.....	8-18
Alternator chain and Tensioner Removal.....	8-18
Alternator Chain and Tensioner Installation.....	8-18
Alternator Shaft and Starter Clutch Removal.....	8-18
Alternator Shaft and Starter Clutch Installation	8-19
Alternator Shaft Chain Wear.....	8-19
Starter Motor Clutch Inspection.....	8-19
Transmission.....	8-20
External Shift Mechanism Removal	8-20
External Shift Mechanism Installation.....	8-20
External Shift Mechanism Inspection	8-21
Transmission Shaft Removal	8-21
Transmission Shaft Installation	8-21
Transmission Disassembly.....	8-22
Transmission Assembly	8-22
Shift Drum and Fork Removal.....	8-23
Shift Drum and Fork Installation	8-23

8-2 CRANKSHAFT / TRANSMISSION

Exploded View

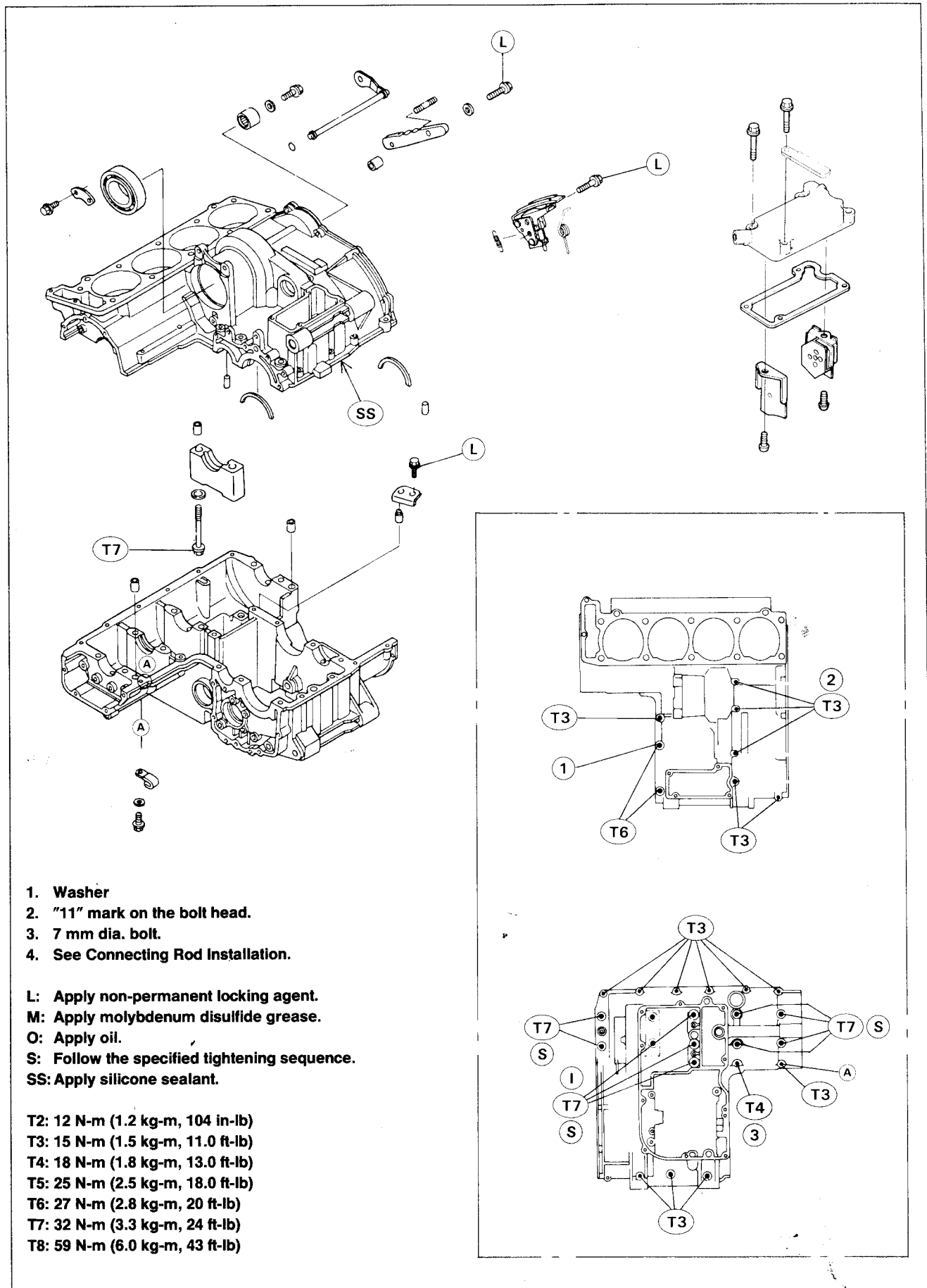

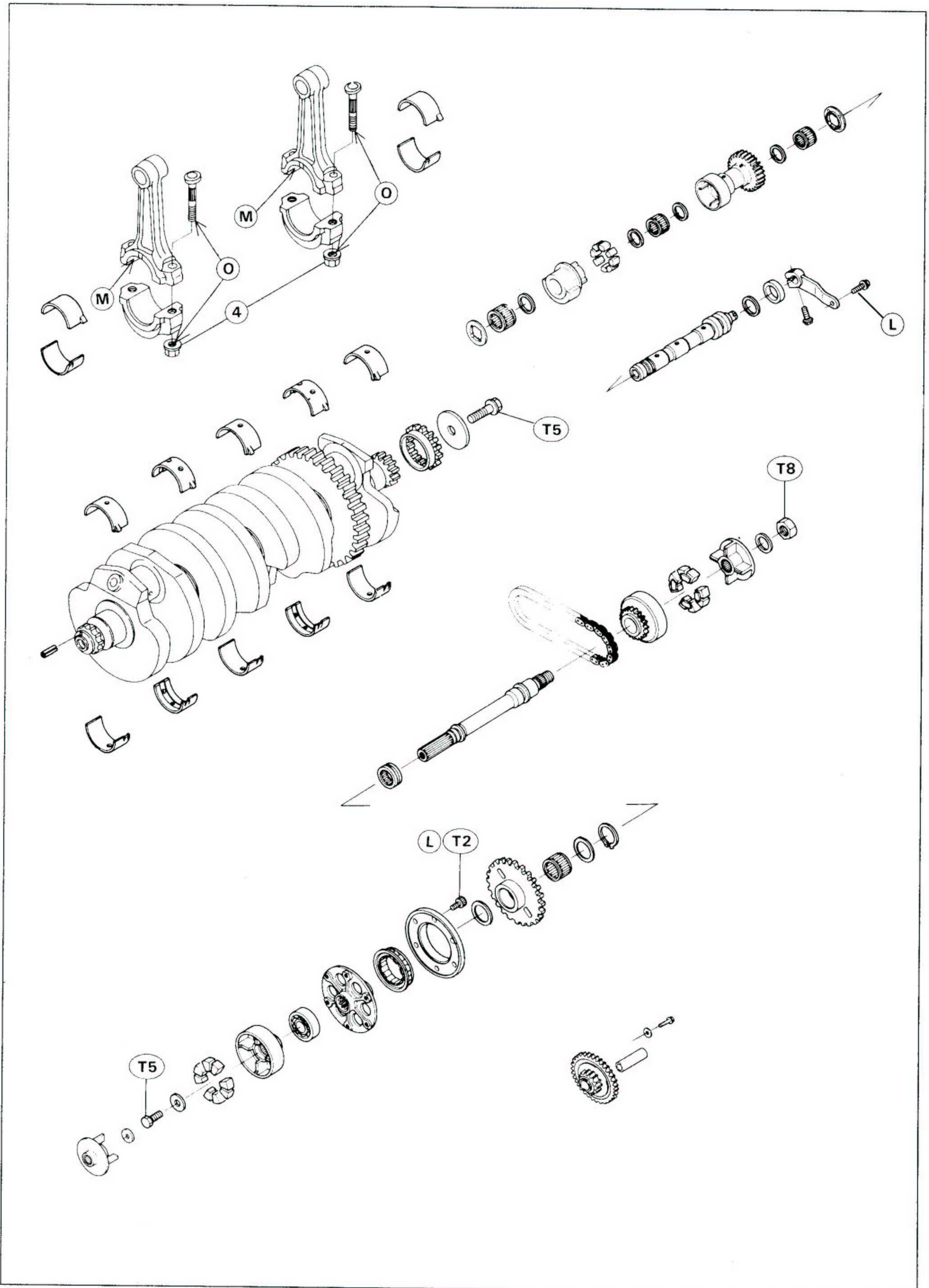

8-4 CRANKSHAFT / TRANSMISSION

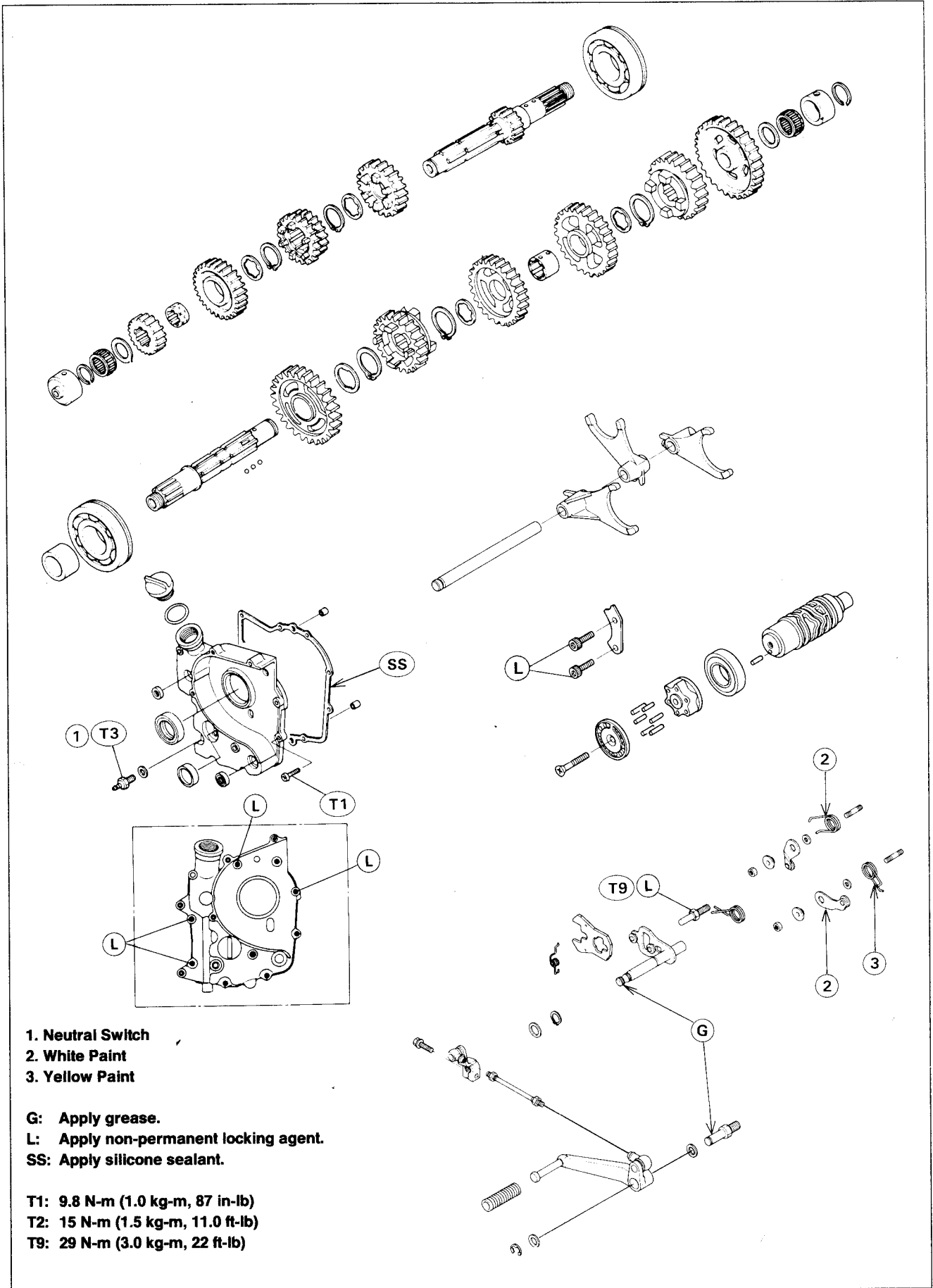

- 1. Neutral Switch
- 2. White Paint
- 3. Yellow Paint

G: Apply grease.
 L: Apply non-permanent locking agent.
 SS: Apply silicone sealant.

T1: 9.8 N-m (1.0 kg-m, 87 in-lb)
 T2: 15 N-m (1.5 kg-m, 11.0 ft-lb)
 T9: 29 N-m (3.0 kg-m, 22 ft-lb)

Specifications

Item	Standard	Service Limit
Crankshaft, Connecting Rods:		
Connecting rod bend	---	0.2/100 mm
Connecting rod twist	---	0.2/100 mm
Connecting rod big end side clearance	0.13 ~ 0.38 mm	0.50 mm
Connecting rod big end bearing insert/crankpin clearance	0.037 ~ 0.065 mm	0.10 mm
Crankpin diameter:	35.984 ~ 36.000 mm	35.97 mm
Marking None	35.984 ~ 35.992 mm	---
○	35.993 ~ 36.000 mm	---
Connecting rod big end bore diameter:	39.000 ~ 39.016 mm	---
Marking None	39.000 ~ 39.008 mm	---
○	39.009 ~ 39.016 mm	---
Connecting rod big end bearing insert thickness:		
Black	1.475 ~ 1.480 mm	---
Blue	1.480 ~ 1.485 mm	---
White	1.485 ~ 1.490 mm	---

Connecting rod big end bearing insert selection:

Con-Rod Big End Bore Diameter Marking	Crankpin Diameter Marking	Bearing Insert	
		Size Color	Part Number
○	○	Blue	92028-1680
None	None		
○	None	White	92028-1681
None	○	Black	92028-1679

Crankshaft main bearing insert/journal clearance	0.020 ~ 0.044 mm	0.07 mm
Crankshaft main journal diameter:	35.984 ~ 36.000 mm	35.96 mm
Marking None	35.984 ~ 35.992 mm	---
1	35.993 ~ 36.000 mm	---
Crankcase main bearing bore diameter:	39.000 ~ 39.016 mm	---
Marking ○	39.000 ~ 39.008 mm	---
None	39.009 ~ 39.016 mm	---
Crankshaft main bearing insert thickness:		
Brown	1.490 ~ 1.494 mm	---
Black	1.494 ~ 1.498 mm	---
Blue	1.498 ~ 1.502 mm	---

Crankshaft main bearing insert selection:

Crankcase Main Bearing Bore Diameter Marking	Crankshaft Main Journal Diameter Marking	Bearing Insert*		
		Size Color	Part Number	Journal Nos.
○	1	Brown	92028-1102	2, 4
			92028-1274	1, 3, 5
None	None	Blue	92028-1100	2, 4
			92028-1272	1, 3, 5
○	None	Black	92028-1101	2, 4
None	1		92028-1273	1, 3, 5

*The bearing inserts for Nos. 2 and 4 journals have an oil groove.

8-6 CRANKSHAFT / TRANSMISSION

Item	Standard	Service Limit
Crankshaft side clearance Crankshaft runout	0.05 ~ 0.20 mm Less than 0.02mm TIR	0.40 mm 0.05 mm TIR
Alternator Shaft: Alternator shaft chain 20 link length	158.5 ~ 159.2 mm	161.2 mm
Transmission: Shift fork ear thickness Gear shift fork groove width Shift fork guide pin diameter Shift drum groove width	4.9 ~ 5.0 mm 5.05 ~ 5.15 mm 7.9 ~ 8.0 mm 8.05 ~ 8.20 mm	4.8 mm 5.3 mm 7.8 mm 8.3 mm

Special Tool – Steering Stem Bearing Driver: 57001-137

Bearing Puller: 57001-158

Inside Circlip Pliers: 57001-143

Bearing Puller Adapter: 57001-317

Bearing Driver Set: 57001-1129

Sealant – Kawasaki Bond (Silicone Sealant): 56019-120

Kawasaki Bond (Liquid Gasket – Black): 92104-1003

Crankcase Splitting

Crankcase Splitting

- Remove the engine (see Engine Removal/Installation chapter).
- Set the engine on a clean surface and hold the engine steady while parts are being removed.
- Remove the following parts from the engine.

External Shift Mechanism	Alternator Chain Tensioner
Starter Motor	Oil Pan
Alternator	Oil Pump with Bracket
Pickup Coil	
Right Engine Cover	

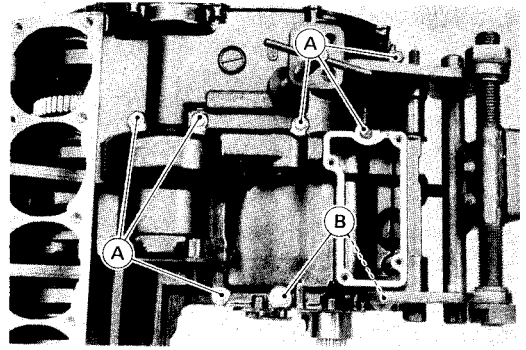

Remove the following parts only if the crankshaft is to be removed.

- Cylinder Head
- Cylinder Block
- Pistons
- Alternator Shaft Chain and Sprockets

Remove the following part only if the transmission drive shaft assembly is to be removed.

Clutch

- Remove the upper crankcase bolts.
 - 6 mm Bolt [A]
 - 8 mm Bolt [B]
 - Remove the lower crankcase bolts.
 - 6 mm Bolt [A]
 - 9 mm Bolt [B]
- Removal of bolts [C] is not necessary for crankcase split.
7 mm Bolt [D]

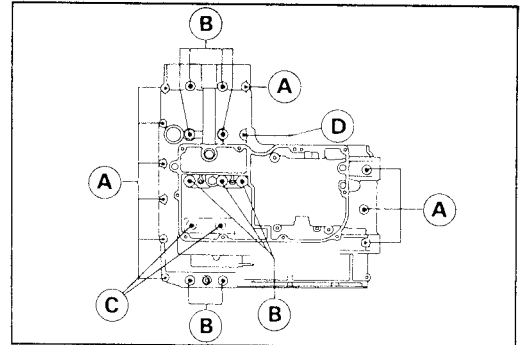

- Pry the points indicated in the figure [A] to split the crankcase halves apart, and remove the lower crankcase half.

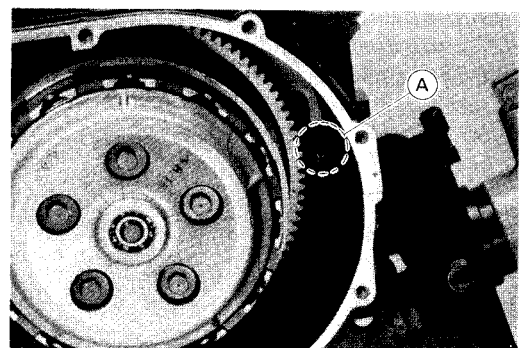
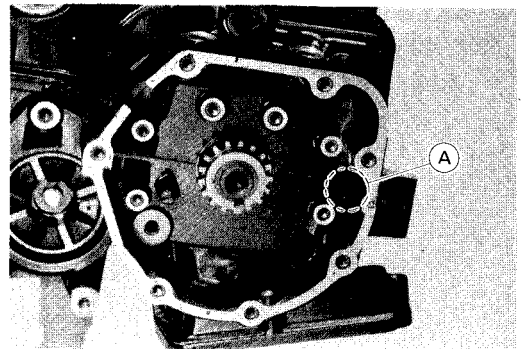

8-8 CRANKSHAFT / TRANSMISSION

Crankcase Assembly

NOTE

○ The upper crankcase half, the lower crankcase half, and the crankshaft main bearing cap are machined at the factory in the assembled state, so the crankcase halves and the main bearing cap must be replaced together as a set.

- Assembly is the reverse of splitting. Note the following.
- Check that the knock pins [A] are in place.

- Shift drum is in the neutral position (neutral positioning lever [A] fits in to the detent [B] on the shift drum bearing holder).
- #1 and 4 pistons are at TDC.

- With a high flash-point solvent, clean off the mating surfaces of the crankcases halves and wipe dry.
- Apply a liquid gasket to the mating surface of the lower crankcase half.

Sealant – Kawasaki Bond (Silicone Sealant): 56019-120

CAUTION

Do not apply a liquid gasket around the crankshaft main bearing inserts [A].

- Hold the balancer so that the mark on the balancer weight aligns with the center of the oil passage hole [A].

- Apply a silicone sealant to the following.
Crankcase Mating Surfaces (both upper and lower)
- Do not apply a silicone sealant to the area shown [A].

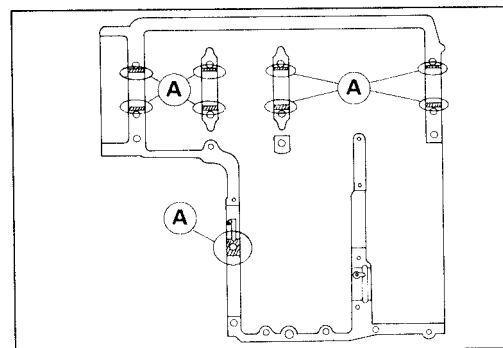
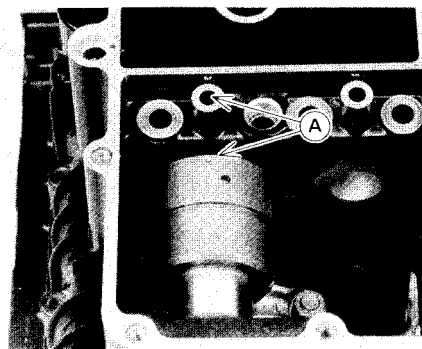
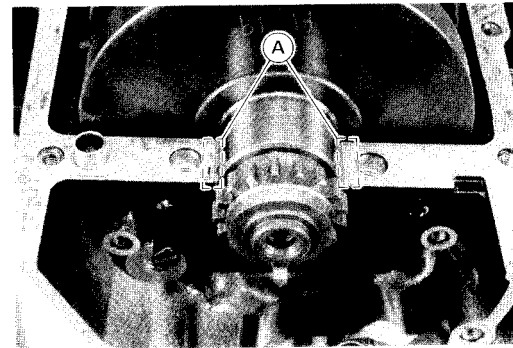
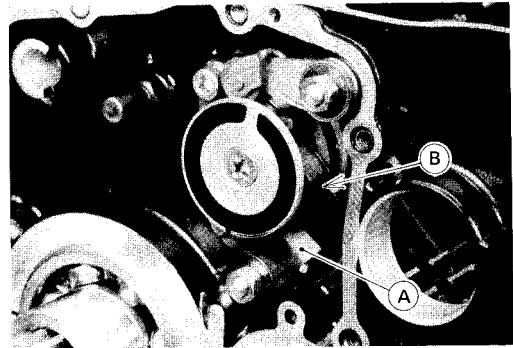
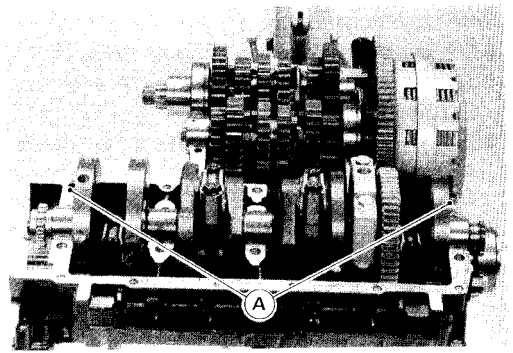

- Tighten the lower crankcase half bolts using the following 4 steps.
- Lightly tighten all lower crankcase half bolts to a snug fit. The three 9 mm bolts (sequence numbered 1 through 3) have a flat washer.
- Following the sequence numbers on the lower crankcase half tighten the 9 mm bolts.

Torque – 9 mm Bolts

First: 9.8 N-m (1.0 kg-m, 87 in-lb)

Final: 32 N-m (3.3 kg-m, 24 ft-lb)

- Tighten the 7 mm bolt.

Torque – 7 mm Bolt: 18 N-m (1.8 kg-m, 13.0 ft-lb)

- Tighten the 6 mm Bolt.

Torque – 6 mm Bolt: 15 N-m (1.5 kg-m, 11.0 ft-lb)

- After tightening all crankcase bolts, check the following items.

- Drive shaft and output shafts turn freely.
- While spinning the output shaft, gears shift smoothly from the 1st to 6th gear, and 6th to 1st.
- When the output shaft stays, still the gear can not be shift to 2nd gear or other higher gear positions.

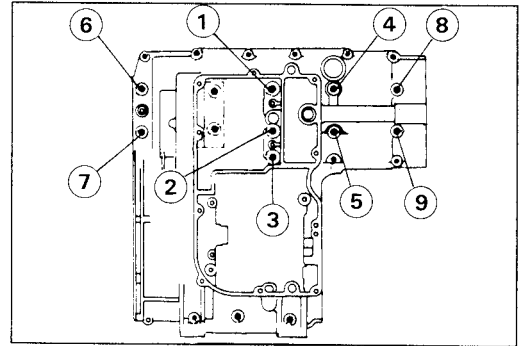

8-10 CRANKSHAFT / TRANSMISSION

Crankshaft and Connecting Rods

Crankshaft Removal

- Split the crankcase.
- Remove the main bearing cap bolts with flat washers, and take off the cap.

Crankshaft Installation Notes

CAUTION

If the crankshaft or bearing inserts are replaced with a new one, check clearance with plastigauge before assembling engine to be sure the correct bearing inserts are installed.

- Install the crankshaft main bearing cap with the arrow [A] on it pointing forward.
- Tighten the main bearing cap bolts.

Torque – Main Bearing Cap Bolts: 32 N-m (3.3 kg-m, 24 ft-lb).

Connecting Rod Removal

- Remove the crankshaft.

NOTE

○ Make and record locations of the connecting rods and their big end caps so that they can be re-assembled in their original positions.

- Remove the connecting rods from the crankshaft.

CAUTION

To prevent damage to the crankpin surfaces, do not allow the big end cap bolts to bump against them.

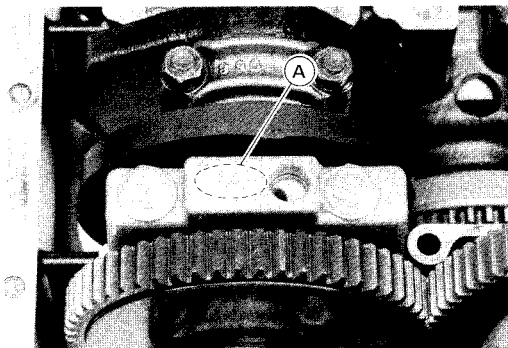

Connecting Rod Installation Notes

- To minimize vibration, a pair of connecting rod (left two rods or right two) should have the same weight mark [A]. The left two rods are a pair and the right two rods are pair. The weight mark is indicated by a capital letter, and is stamped on the connecting rod big end.
- Before installing the connecting rods, blow the crankshaft oil passages with compressed air to remove any foreign particles or residue that may have accumulated in the passages.

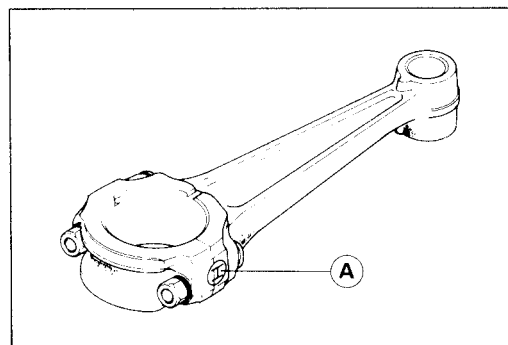

- If the connecting rods or bearing inserts are replaced with new ones, check clearance with plastigage before assembling engine to be sure the correct bearing inserts are installed.
- Apply molybdenum disulfide grease to the upper inner surface [A] of the connecting rod big end.

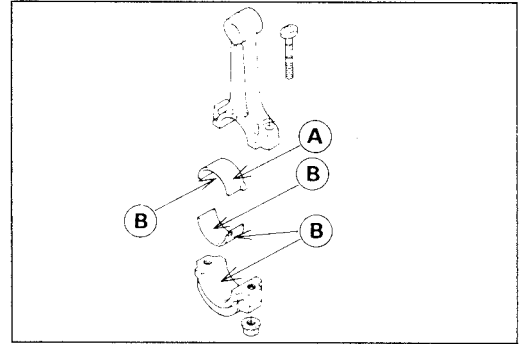

CAUTION

Do not apply grease to the inner surface [B] of the upper or lower bearing inserts or to the outer surface of the lower bearing insert.

- The connecting rod bolts are designed to stretch when tightened. Never reuse them. Replace the connecting rod big end bolts with new ones.
- The new connecting rod bolt and nut are treated with an anti-rust solution, be sure to clean the bolt and nut thoroughly with high flash-point solvent.

◦ ⚠ WARNING

Clean the bolts and nuts in a well-ventilated area, and take care that there is no spark or flame anywhere near the working area, this includes any appliance with a pilot light. Because of the danger of highly flammable liquids, do not use gasoline or low flash-point solvents to clean the bolts and nuts.

CAUTION

Immediately dry the bolts and nuts with compressed air after cleaning.
Clean and dry the bolts and nuts completely.

- Apply a small amount of engine oil to the threads and seating surface of the connecting rod nuts.
- Tighten the nuts.

Torque – Connecting Rod Big End Cap Nuts : 15 N-m (1.5 kg-m, 11.0 ft-lb)

- Tighten the nuts **120°** more.
- Mark [A] the connecting rod big end caps and nuts so that nuts can be turned 120° [B] properly.
- Tighten the hexagonal nut by 2 corners.

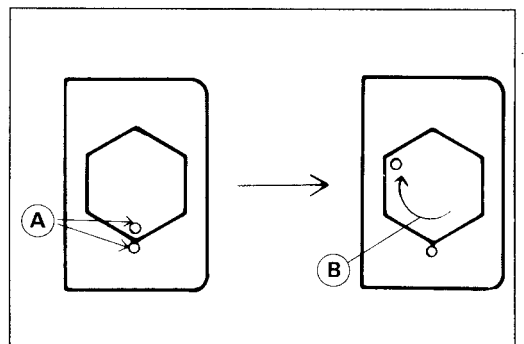

8-12 CRANKSHAFT / TRANSMISSION

CAUTION

Be careful not to overtighten the nuts.
Be careful not to turn the connecting rod bolts during the nut tightening. The bolts must be positioned correctly to avoid the bolt heads (#1 and #2 cylinder rear side bolts) contact to the crankcase.

- [A] Bolt Head
- [B] Connecting Rod Big End Shoulder
- [C] Bolt Correct Position
- [D] Do not over turn at this position.

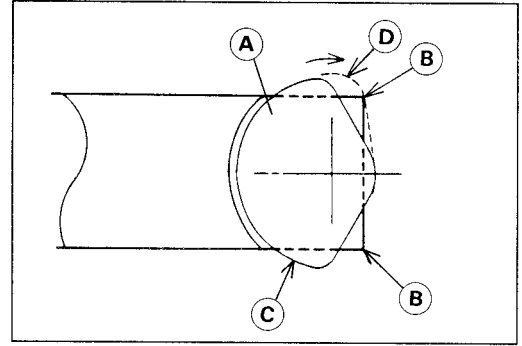

Connecting Rod Big End Bearing Insert/Crankpin Wear

- Using a plastigage (press gauge) [A], measure the bearing insert/crankpin [B] clearance.

NOTE

- Tighten the big end cap nuts to the specified torque (see Connecting Rod Installation Notes).
- Do not move the connecting rod and crankshaft during clearance measurement.

Connecting Rod Big End Bearing Insert/Crankpin Clearance

Standard: 0.037 ~ 0.065 mm

Service Limit: 0.10 mm

- ★ If clearance is within the standard, no bearing replacement is required.
- ★ If clearance is between 0.066 mm and the service limit (0.10 mm), replace the bearing inserts with inserts painted blue [C]. Check insert/crankpin clearance with a plastigage. The clearance may exceed the standard slightly, but it must not be less than the minimum in order to avoid bearing seizure.
- ★ If the clearance exceeds the service limit, measure the diameter of the crankpins.

Crankpin Diameter

Standard: 35.984 ~ 36.000 mm

Service Limit: 35.97 mm

- ★ If any crankpin has worn past the service limit, replace the crankshaft with a new one.
- ★ If the measured crankpin diameters are not less than the service limit, but do not coincide with the original diameter markings on the crankshaft, make new marks on it.

Crankpin Diameter Marks

None 35.984 ~ 35.992 mm

○ 35.993 ~ 36.000 mm

▲: Crankpin Diameter Marks, "○" mark or no mark.

- Measure the connecting rod big end bore diameter, and mark each connecting rod big end in accordance with the bore diameter. Bore diameter Mark (Around Weight Mark) [A]: "○" or no mark.

NOTE

- Tighten the connecting rod big end cap nuts to the specified torque (see Connecting Rod Installation Notes).
- The mark already on the big end should almost coincide with the measurement.

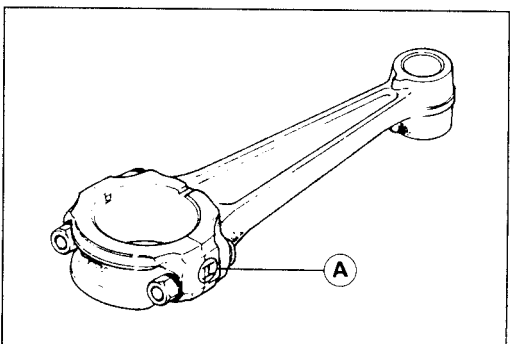
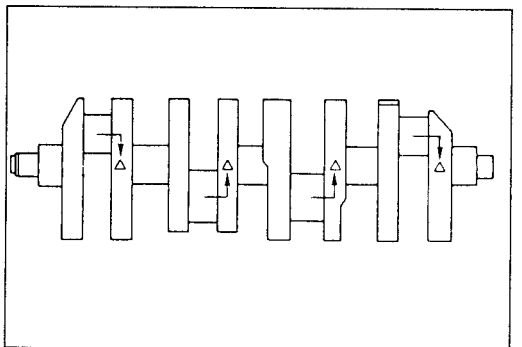
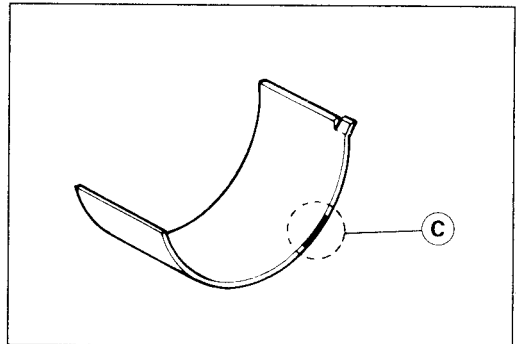
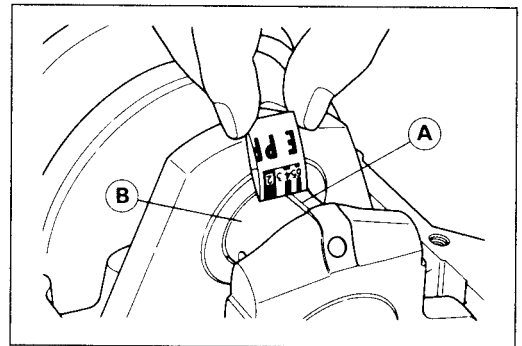

Connecting Rod Big End Bore Diameter

None	39.000 ~ 39.008 mm
○	39.009 ~ 39.016 mm

- Select the proper bearing insert in accordance with the combination of the connecting rod and crankshaft coding.
- Install the new inserts in the connecting rod and check insert/crankpin clearance with the plastigage.

Con-rod Big End Bore Diameter Marking	Crankpin Diameter Mark	Bearing Insert	
		Size Color	Part Number
○	○	Blue	92048-1680
None	None		
○	None	White	92028-1681
None	○	Black	92028-1679

Crankshaft Main Bearing Insert/Journal Wear

- Using a plastigage (press gauge) [A], measure the bearing insert/journal [B] clearance.

NOTE

- Tighten the crankcase bolts to the specified torque (see Crankcase Assembly Notes).
- Do not turn the crankshaft during clearance measurement.

Crankshaft Main Bearing Insert/Journal Clearance

Standard:	0.020 ~ 0.044 mm
Service Limit:	0.08 mm

- ★ If clearance is within the standard, no bearing replacement is required.
- ★ If clearance is between 0.044 mm and the service limit (0.08 mm), replace the bearing inserts with inserts painted blue [C]. Check insert/journal clearance with the plastigage. The clearance may exceed the standard slightly, but it must not be less than the minimum in order to avoid bearing seizure.
- ★ If clearance exceeds the service limit, measure the diameter of the crankshaft main journal.

Crankshaft Main Journal Diameter

Standard:	35.984 ~ 36.000 mm
Service Limit:	35.96 mm

- ★ If any journal has worn past the service limit, replace the crankshaft with a new one.
- ★ If the measured journal diameters are not less than the service limit, but do not coincide with the original diameter markings [D] on the crankshaft, make new marks on it.

Crankshaft Main Journal Diameter Marks

None	35.984 ~ 35.992 mm
1	35.993 ~ 36.000 mm

□: Crankshaft Main Journal Diameter Marks, "1" mark or no mark

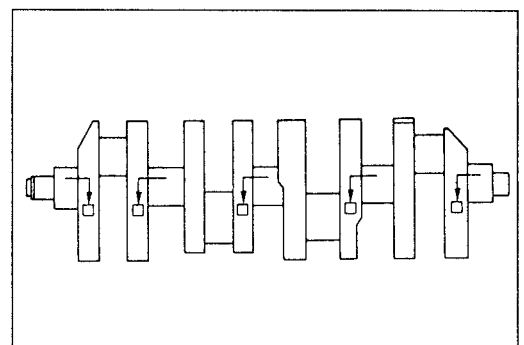
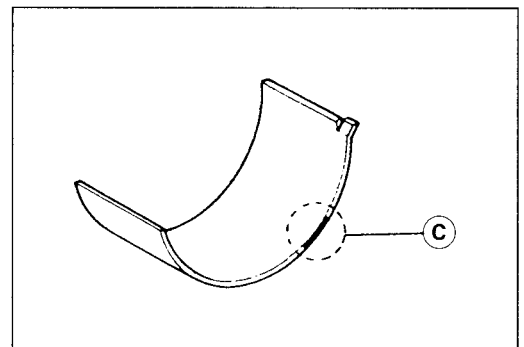
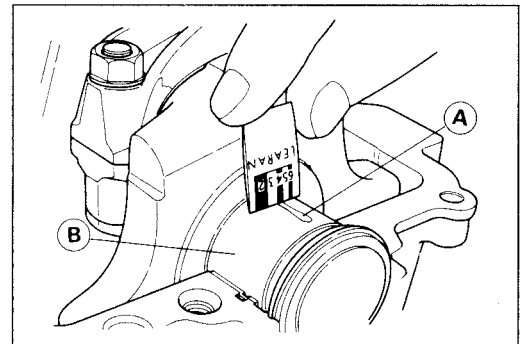

8-14 CRANKSHAFT / TRANSMISSION

- Measure the main bearing bore diameter, and mark the upper crankcase half in accordance with the bore diameter.

Bore Diameter Mark "○" or no mark

NOTE

- Tighten the crankcase bolts to the specified torque (see Crankcase Assembly Notes).
- The mark already on the upper crankcase half should almost coincide with the measurement.

Crankcase Mark Location

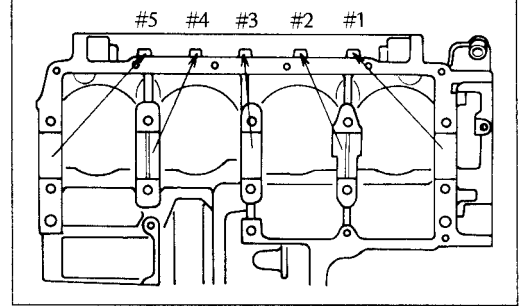

Crankcase Main Bearing Bore Diameter

○	39.000 ~ 39.008 mm
None	39.009 ~ 39.016 mm

- Select the proper bearing insert in accordance with the combination of the crankcase and crankshaft coding.
- Install the new inserts in the crankcase halves and cap and check insert/journal clearance with a plastigage.

Crankcase Main Bearing Bore Diameter Marking	Crankshaft Main Journal Diameter Marking	Bearing Insert*		
		Size Color	Part Number	Journal Nos.
○	1	Brown	92028-1102	2, 4
			92028-1274	1, 3, 5
None	None	Blue	92028-1100	2, 4
			92028-1272	1, 3, 5
○	None	Black	92028-1101	2, 4
None	1		92028-1273	1, 3, 5

*The bearing inserts for Nos. 2 and 4 journals have an oil groove.

Crankshaft Side Clearance

- Insert a thickness gauge between the crankcase main bearing and the crank web [A] at the No. 2 journal [B] to determine clearance.
- ★ If the clearance exceeds the service limit, replace the crankcase halves and main bearing cap as a set.

CAUTION

The upper crankcase half, lower crankcase half, and main bearing cap are machined at the factory in the assembled state, so they must be replaced as a set.

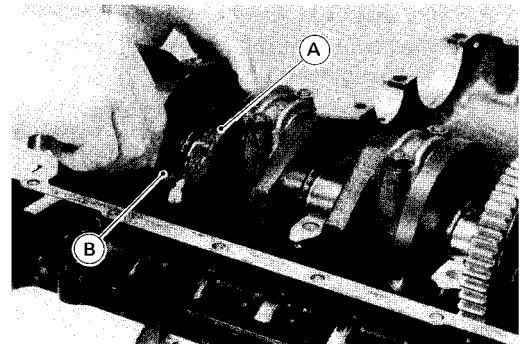

Crankshaft Side Clearance

Standard:	0.05 ~ 0.20 mm
Service Limit:	0.40 mm

Crankshaft Runout

- Measure the crankshaft runout.
- ★ If the measurement exceeds the service limit, replace the crankshaft.

Crankshaft Runout

Service Limit: 0.05 mm TIR

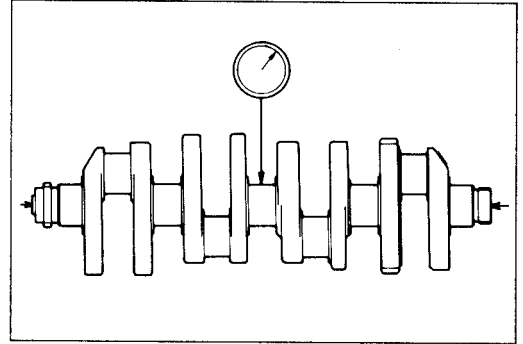

8-16 CRANKSHAFT / TRANSMISSION

Balancer

Balancer Removal

- Split the crankcase.
- Unscrew the balancer shaft clamp bolts, and pull off the clamp lever.
- Unscrew the balancer shaft guide pin plate, and take off the plate and guide pin.
- Pull the balancer shaft with the oil seal toward the right out of the crankcase. At the same time, the balancer weight and gear assembly comes off.

Balancer Installation Notes

- When coupling the balancer weight and the gear, observe the following.
 - Check that the damper rubbers are in place.
 - Fit the balancer weight into the gear so that the weight [A] is opposite the mark [B] on the gear.
- Fit the copper washers on both sides of the weight and gear assembly. The projected side [A] faces toward the assembly.

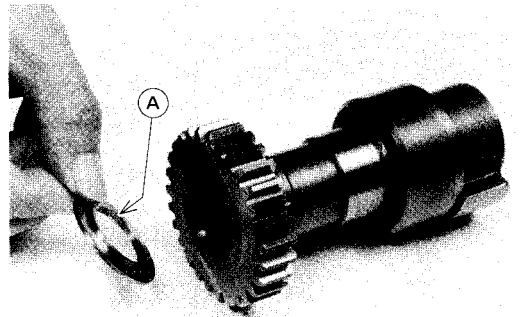
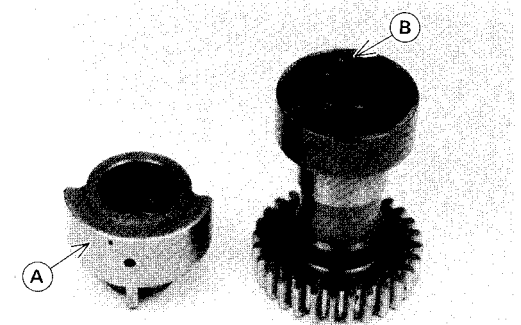

- Turn the balancer shaft until the line mark on the end of the shaft points to the front. And then, install the clamp lever. Tighten the bolt at the rear of the lever first then tighten the clamp bolt at the front of the lever temporarily.

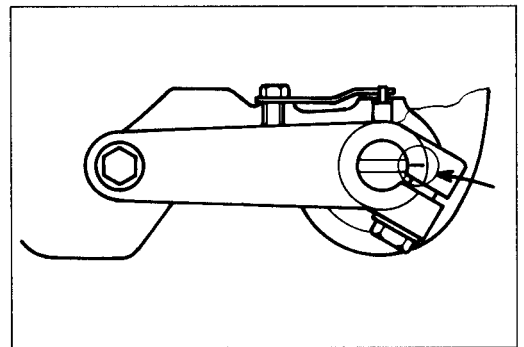

- Adjust the balancer gear backlash during the preparation of the motorcycle. The amount of backlash can be changed by turning the balancer shaft.
 - Start the engine and let it at idle.
 - Loosen the clamp bolt and turn the balancer shaft counterclockwise until the balancer gear makes a noise.
 - Turn the shaft clockwise until the balancer gear stops to make a noise, and tighten the clamp bolt securely.

Damper Inspection

- Remove the balancer and disassemble the weight and gear assembly.
- Visually inspect the rubber dampers [A].
- ★ If they appear damaged or deteriorated, replace them.

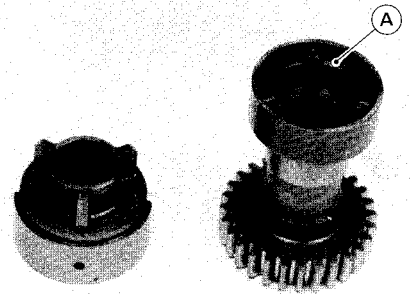

Needle Bearing Wear

- Visually check the needle bearing.
- The rollers in a needle bearing normally wear very little, and wear is difficult to measure. Instead of measuring, inspect the bearing for abrasion, color change, or other damage.
- ★ If there is any doubt as to the condition of a needle bearing, replace it.

8-18 CRANKSHAFT / TRANSMISSION

Alternator Shaft/Starter Motor Clutch

Alternator chain and Tensioner Removal

- Remove the right engine cover.
- Lock the alternator shaft chain tensioner.
- Push the tensioner guide and the rod stop lever so that the stop lever keeps the rod from returning.

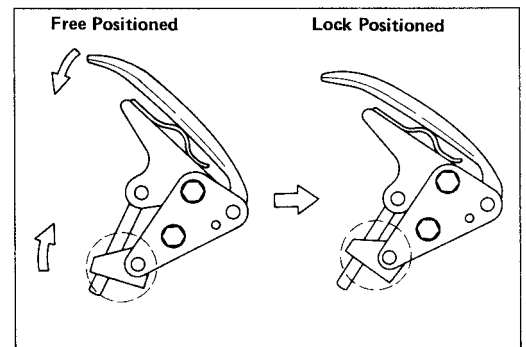

- Remove the chain guide [C].

[A] Alternator Chain Tensioner
[B] Bolts

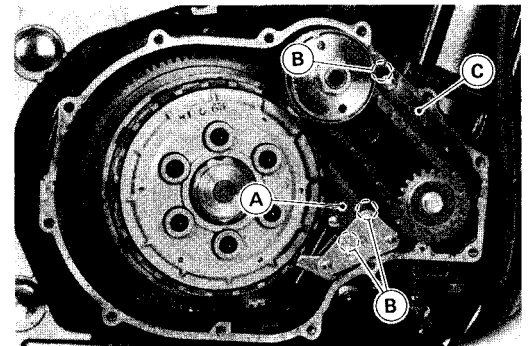

- Remove the alternator chain tensioner.
- Hold the alternator coupling with the coupling holder, and remove the coupling nut and sprocket bolt.

Special Tool – Coupling Holder: 57001-1189 [A]

- Pull the chain, sprocket, and coupling as a set.

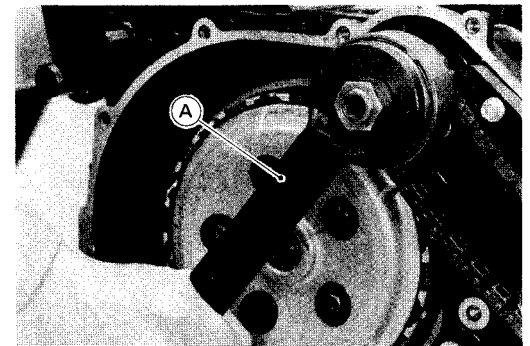

Alternator Chain and Tensioner Installation

- Installation is the reverse of removal. Note the following.
- Tighten the alternator shaft nut and alternator sprocket bolt.

Torque – Alternator Shaft Nut: 59 N-m (6.0 kg-m, 43 ft-lb)
Alternator sprocket bolt: 25 N-m (2.5 kg-m, 18.0 ft-lb)

- Lock the chain tensioner and install it with the mounting bolts. The tensioner should be free from the locked position after installing it.

Alternator Shaft and Starter Clutch Removal

- Split the crankcase.
- Remove the alternator chain.
- Remove the coupling bolt at the left end of the shaft, and then remove the coupling with the rubber dampers.
- Holding the starter motor clutch, pull the alternator shaft off the crankcase.

Alternator Shaft and Starter Clutch Installation

- Installation is the reverse of removal. Note the following.
- If the starter motor idle gear [A] is removed, install it so that the small diameter gear side faces to the left.

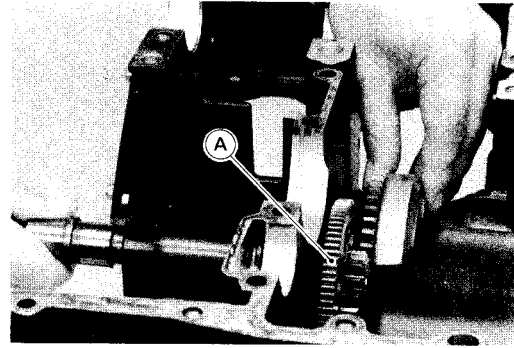

- Tighten the one-way clutch bolt.

Torque – One-way Clutch Bolt: 12 N-m (1.2 kg-m, 104 in-lb)

Alternator Shaft Chain Wear

- Hold the alternator shaft chain so that it may be pulled tight.
- Measure the length of 20 links (21 pins) with a vernier caliper.
- ★ If the 20-link length of the alternator shaft chain is greater than the service limit, replace it.

Alternator shaft Chain 20-link length
Standard: 158.8 ~ 159.2 mm
Service Limit: 161.2 mm

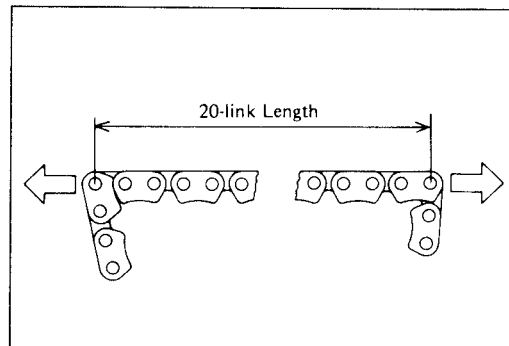

Starter Motor Clutch Inspection

- Remove the starter motor.
- Turn the starter motor idle gear by hand. When viewed from the left side of the engine, the idle gear should turn counterclockwise freely [A], but should not turn clockwise [B].

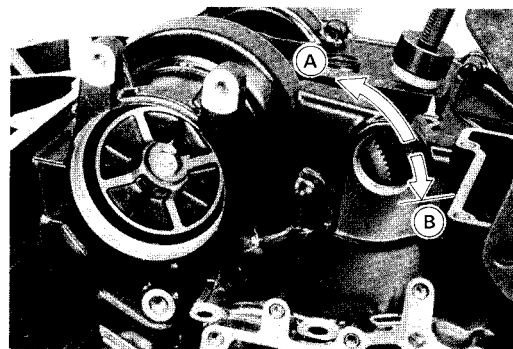

8-20 CRANKSHAFT / TRANSMISSION

Transmission

External Shift Mechanism Removal

- Drain the engine oil.
- Remove the engine (see Engine Removal/Installation chapter).
- Remove the following.
 - Engine Sprocket
 - Water Pump
 - External Mechanism Cover

- Remove the shift shaft, while moving the shift mechanism arm backward.
 - [A] Neutral Positioning Lever
 - [B] Gear Positioning Lever
 - [C] Shift Mechanism Arm
 - [D] Arm Spring
 - [E] Return Spring
 - [F] Shift Shaft
- Unscrew the nuts and remove the positioning levers.

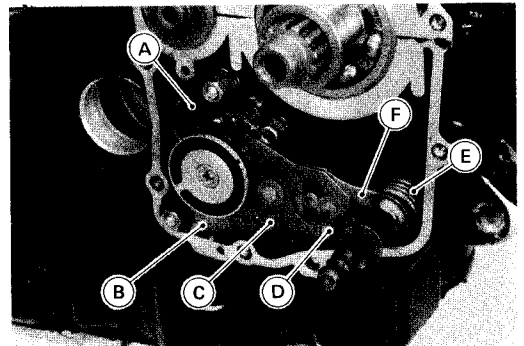

External Shift Mechanism Installation

- Installation is the reverse of removal. Note the following.
- The positioning levers [A] are identical. The spring [D] painted white is for the gear positioning lever [B].
- The projected side of the collar must face toward the lever.
 - [C] Change Drum

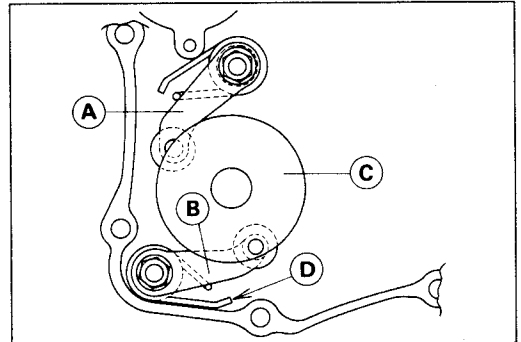

- Apply a silicone sealant to the following.

- [A] Silicone Sealant Applied Area
- [B] Crankcase Mating surface
- [C] 5 mm

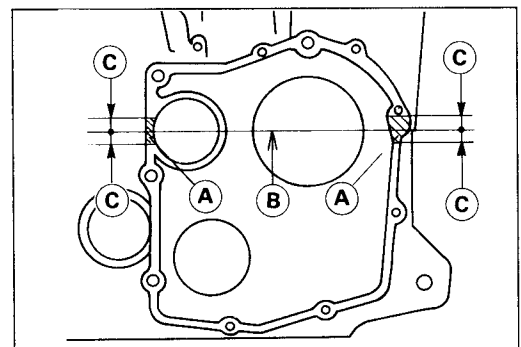

- Apply a non-permanent locking agent to the cover bolts [A].

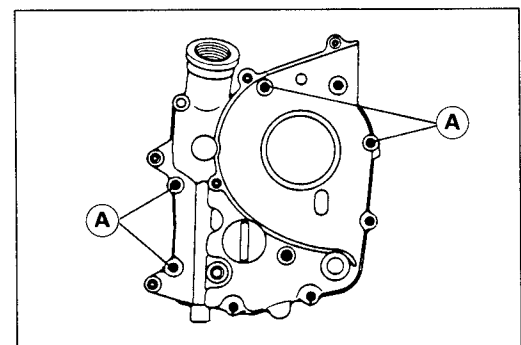

- Tighten the external shift mechanism cover bolt and neutral switch if removed.

Torque – External Shift Mechanism Cover bolts:

9.8 N-m (1.0 kg-m, 87 in-lb)

Neutral Switch: 15 N-m (1.5 kg-m, 11.0 ft-lb)

- Adjust the shift pedal position correctly if the shift pedal linkage was disassembled.
 - Loosen the locknuts [C] and turn the rod [D] to adjust the shift pedal position.
 - Tighten the locknuts.
- [A] Frame Edge [B] Pedal Correct Position

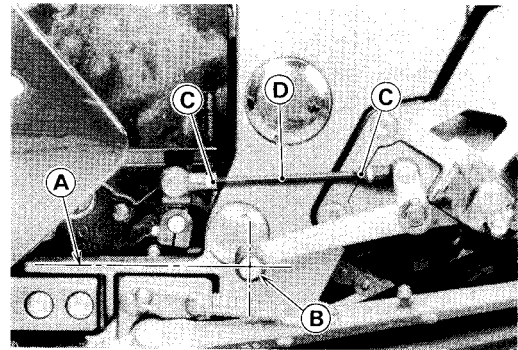

External Shift Mechanism Inspection

- Examine the shift shaft for any damage.
- ★ If the shaft is bent, straighten or replace it. If the splines [A] are damaged, replace the shaft.
- ★ If the springs [B] [C] are damaged in any way, replace them.
- ★ If the shift mechanism arm [D] is damaged in any way, replace the arm.

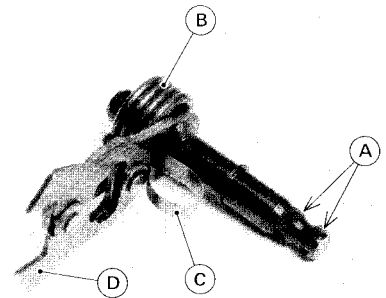

- Check the return spring pin [D] is not loose.
- ★ If it is loose, unscrew it, apply a non-permanent locking agent to the threads, and tighten it.

Torque – External shift mechanism Return Spring Pin: 29 N-m (3.0 kg-m, 22-lb)

- Check the positioning levers [A] [B] and their springs [C] for breaks or distortion.
- ★ If the levers or springs are damaged in any way, replace them.
- Visually inspect the shift drum pins, pin holder, and pin plate.
- ★ If they are badly worn or if they show any damage, replace them.

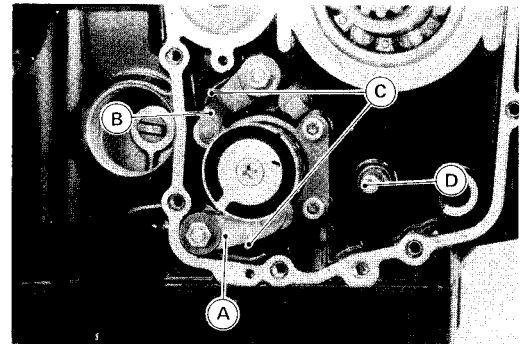

Transmission Shaft Removal

NOTE

○ If the drive shaft assembly is to be disassembled, removed the clutch.

- Split the crankcase.
- Take out the drive and output shaft assemblies.

Transmission Shaft Installation

- Installation is the reverse of removal. Note the following.
- Check to see that the set rings [A] and set pins [B] are in place in the transmission bearing housings, and blow the oil passages [C] in the bearing housings clean with compressed air.

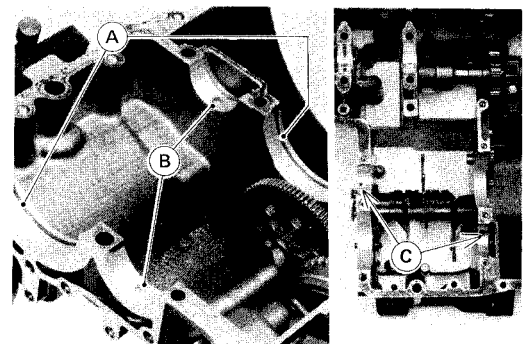

8-22 CRANKSHAFT / TRANSMISSION

- Install the drive and output shaft assemblies in the upper crankcase half.
- The bearing set pins and rings must match properly with the holes or grooves in the bearing outer races. When they are properly matched, there is no clearance between the crankcase and the bearing outer races [A].

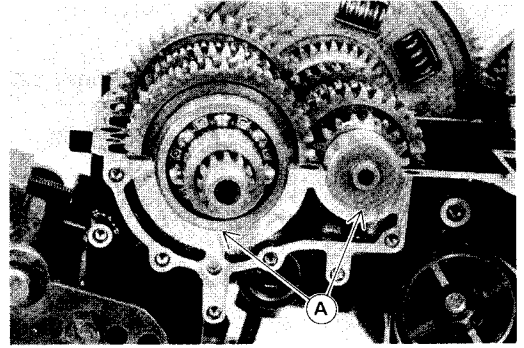

Transmission Disassembly

- Remove the transmission shafts.
- Remove the circlips, disassemble the transmission shafts.

Special Tool – Outside Circlip Pliers: 57001-144

- The 5th gear [A] on the output shaft has three steel balls assembled into it for the positive neutral finder mechanism. Remove the 5th gear.
- Set the output shaft in a vertical position holding the 3rd gear [B]
- Spin the 5th gear quickly [C] and pull it off upward.

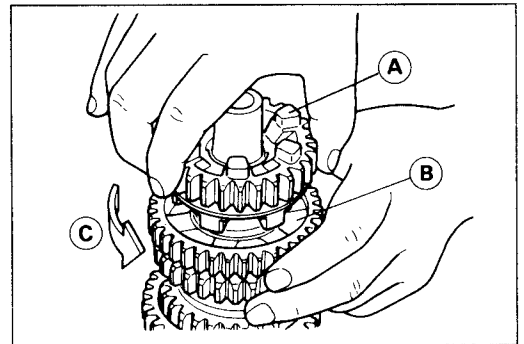

Transmission Assembly

- Assembly is the reverse of disassembly. Note the following.
- Apply engine oil liberally to the following:
 - Transmission Shafts
 - Transmission Gears
 - Ball Bearings, Needle Bearings
 - Bushing
 - Steel Balls
- Replace the ball bearings with new ones.

- Replace any circlips removed with new ones.
- Install the circlips [A] so that the opening [B] is aligned with a spline groove [C].

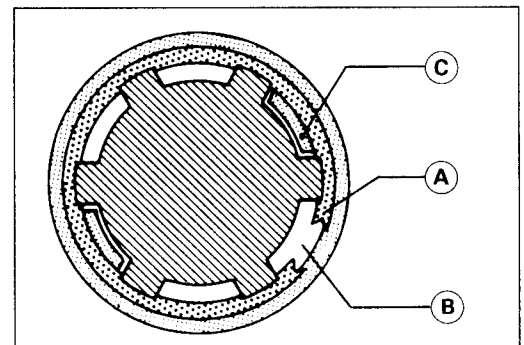

- The drive shaft gears can be recognized by size ; the gear with the smallest diameter being 1st gear, and the largest one being 6th gear. Be sure that all parts are put back in the correct sequence and all circlips and washers are properly in place. Proper sequence starting with 1st gear [A] (part of drive shaft) is 5th gear [B], toothed washer, circlip, 3rd/4th gear [C], circlip toothed washer, bushing 6th gear [D], 2nd gear [E], thrust washer, needle bearing, circlip, needle bearing outer race.

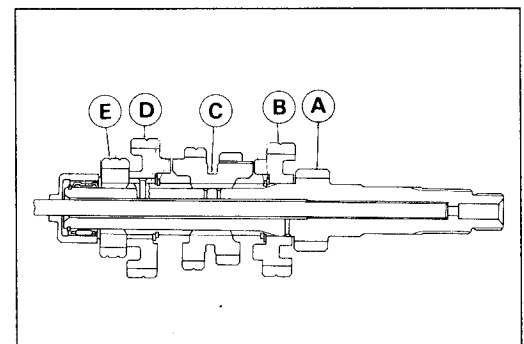

- When assembling the 6th gear bushing to the drive shaft, align its oil hole [A] with the hole [B] in the shaft.

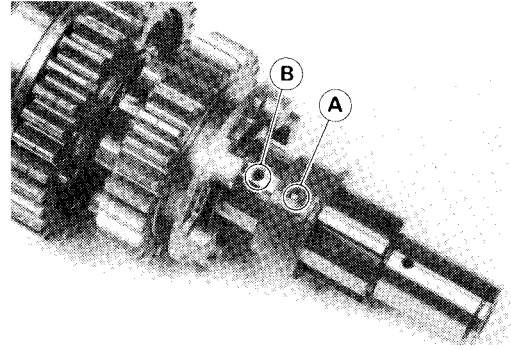

- The output shaft gears can be recognized by size ; the gear with the largest diameter being 1st gear, and the smallest one being 6th gear. Be sure that all parts are put back in the correct sequence and all circlips and washers are properly in place. Proper sequence starting with the engine sprocket side is 2nd gear [A], toothed washer, circlip, 6th gear [B], circlip, toothed washer, bushing, 4th gear [C], 3rd gear [D], toothed washer, circlip, 5th gear [E] with steel balls, 1st gear [F] thrust washer needle bearing, and needle bearing outer race, circlip.

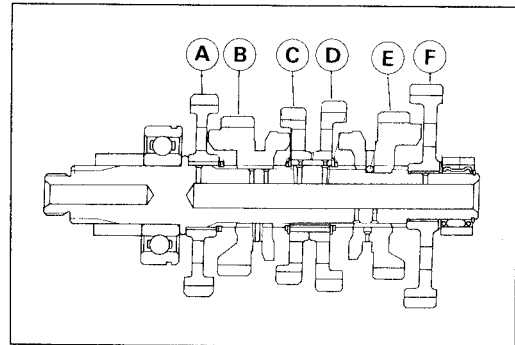

CAUTION

When installing the 5th [A] gear and steel balls [B] on the output shaft, do not apply grease to the balls to hold them in place. This will cause the positive neutral finder mechanism to malfunction.

- After assembling the 5th gear with steel balls in place on the output shaft, check the ball-locking effect that the 5th gear does not come out of the output shaft when moving it up and down by hand.
 - Check that each gear spins or slides freely on the transmission shafts without binding after assembly.
- [C] Recess

Shift Drum and Fork Removal

- Remove the engine (see Engine Removal/Installation chapter).
- Remove the following.
 - External Shift Mechanism
 - Oil Pan
 - Oil Pump and Bracket
- Unscrew the Allen bolts holding the shift drum ball bearing holder.
- Pull out the shift rod [B], and take off the shift forks.
- Pull out the shift drum [A].

Shift Drum and Fork Installation

- Installation is the reverse of removal. Note the following.
- Apply a non-permanent locking agent to the Allen bolts of the shift drum holding plate.
- The shift forks can be identified by their shape. Install them as shown.

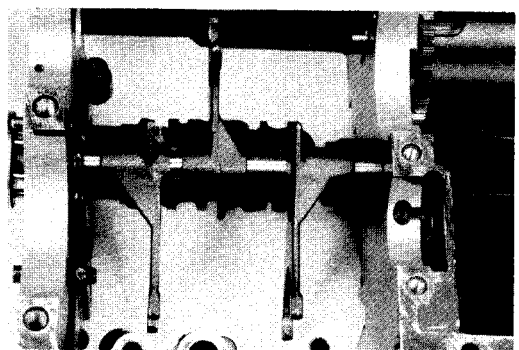
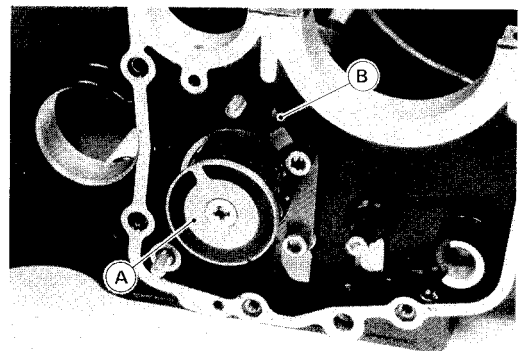
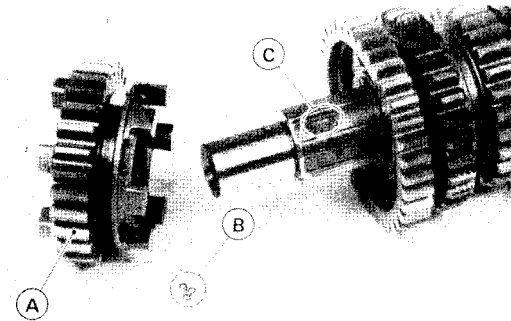

Wheels / Tires

Table of Contents

Exploded View	9-2
Specifications	9-3
Wheels (Rims)	9-4
Front Wheel Removal	9-4
Front Wheel Installation	9-4
Rear Wheel Removal	9-5
Rear Wheel Installation Notes	9-6
Inspection	9-6
Axle Inspection	9-6
Wheel Balance	9-7
Balance Inspection	9-7
Balance Adjustment	9-7
Balance Weight Installation	9-7
Balance Weight Removal	9-9
Air Pressure Inspection/Adjustment	9-9
Inspection	9-9
Installation	9-10
Repair	9-11
Hub Bearing	9-12
Removal	9-12
Installation Notes	9-12
Inspection	9-12
Speedometer Gear Housing	9-13
Disassembly and Assembly	9-13
Lubrication	9-13

9-2 WHEELS / TIRES

Exploded View

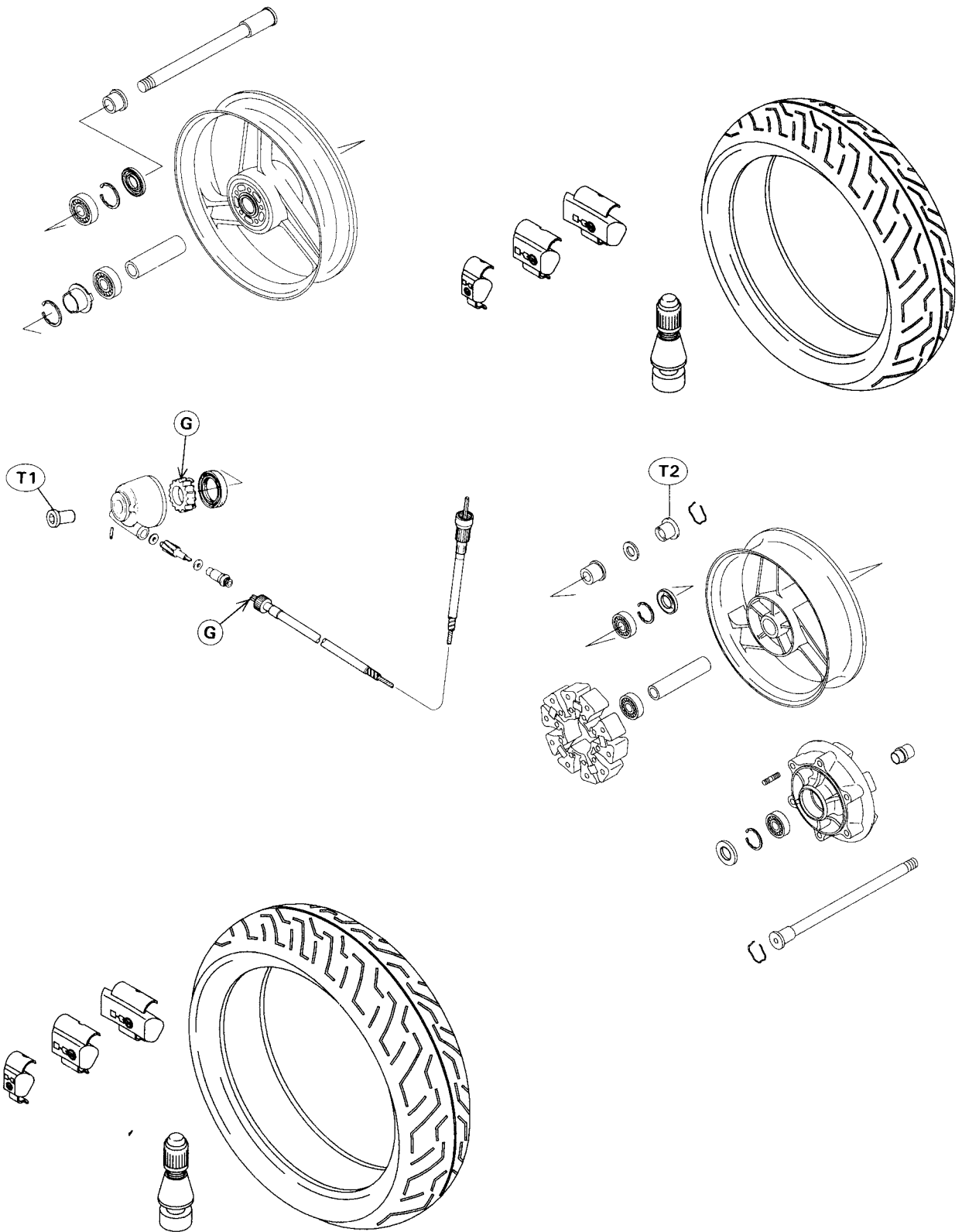

G: Apply grease.

T1 : 145 N-m (15.0 kg-m, 110 ft-lb)

T2 : 110 N-m (11.0 kg-m, 80 ft-lb)

Specifications

Item	Standard	Service Limit
Wheels:		
Rim runout: Axial	---	0.5 mm
Radial	---	0.8 mm
Axle runout/100 mm	---	0.2 mm
Tires:		
Tire air pressure:		
Front	Up to 183 kg (404 lb) load	290 kPa (2.9 kg/cm ² , 41 psi)
Rear	Up to 183 kg (404 lb) load	290 kPa (2.9 kg/cm ² , 41 psi)
Standard tire:		
Front	○ 120/70 ZR17 BRIDGESTONE BATTRAX BT-50F E DUNLOP SPORT D203F METZELER ME33 Laser	
Rear	○ 180/55 ZR17 BRIDGESTONE BATTRAX BT-50R E DUNLOP SPORT D203 METZELER ME55 A Metronic	
Germany (Refer to the above, adding the following):		
Front	METZELER ME Z1 Front Tubeless PIRELLI MTR 03 Tubeless or MTR 01 Tubeless MICHELIN A89X Tubeless or TX 11 BRIDGESTONE BT 54F DUNLOP D204 F/FL	
Rear	METZELER ME Z1 Tubeless or ME Z2 Tubeless PIRELLI MTR 04 Tubeless or MTR 02 Tubeless MICHELIN M89X Tubeless or TX 23 BRIDGESTONE BT 54R DUNLOP D204	
Tire tread depth:	Front Rear	3.4 mm 5.8 mm
		1 mm 2 mm (Under 130 km/h, Under 80 mph) 3 mm (Over 130 km/h, Over 80 mph)

- Special Tools** – Inside Circlip Pliers: 57001-143
 Bearing Driver Set: 57001-1129
 Jack: 57001-1238
 Bearing Remover Shaft: 57001-1265
 Bearing Remover Head, Φ15 x Φ17: 57001-1267
 Bearing Remover Head, Φ20 x Φ22: 57001-1293

9-4 WHEELS / TIRES

Wheels (Rims)

Front Wheel Removal

- Remove the following.
 - Fairing
 - Speedometer Cable Lower End [A]
 - Brake Caliper Mounting Bolts [B]

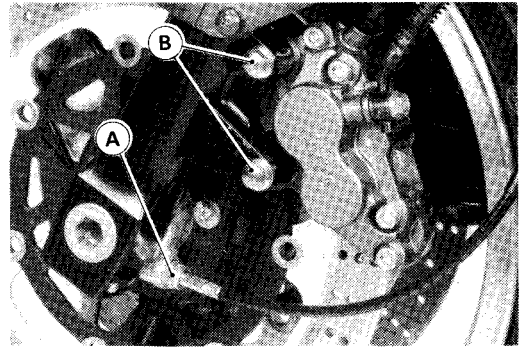

Loosen right side axle clamp bolts [A]
Loosen axle [B]

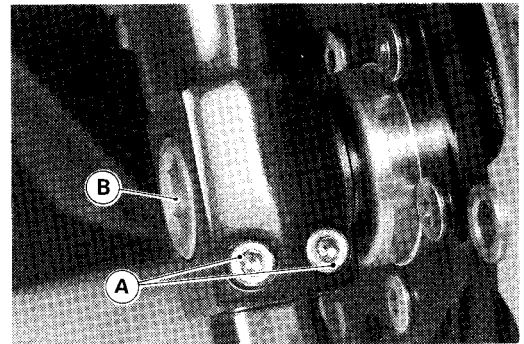

- Raise the front wheel off the ground.
 - Special Tool – Jack: 57001-1238**
- Pull out the axle to the right and drop the front wheel out of the forks.

CAUTION

Do not lay the wheel down on one of the discs. This can damage or warp the disc. Place blocks under the wheel so that the discs do not touch the ground.

Front Wheel Installation

- Installation is the reverse of removal. Note the following.

NOTE

- Put the speedometer gear drive [C] onto the wheel hub notches [A], then install the housing [D] so that it fits in the drive notches.
- [B] Projections

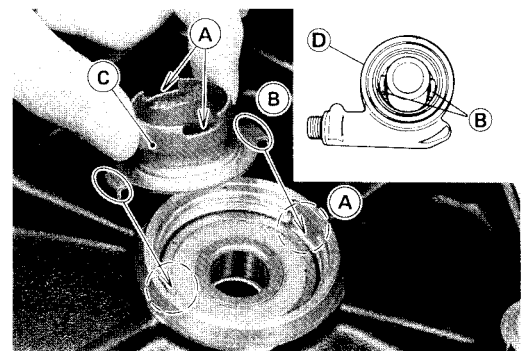

- Fit the collar on the right hand side of the hub.
- Fit the speedometer gear housing stop[A] to the fork leg stop[B].
- Tighten the axle nut and axle clamp bolt.

Torque – Axle Nut: 145 N-m(1.5.0 kg-m, 110 ft-lb)
Axle Clamp Bolts: 20 N-m(2.0 kg-m, 14.5 ft-lb)

- Check the front brake.

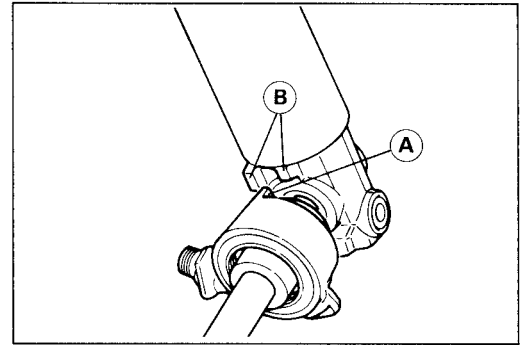

⚠ WARNING

Do not attempt to drive the motorcycle until fully depressing the brake lever then pump the brake lever until the pads are against the disc. The brakes will not function on the first application of the lever if this is not done.

Rear Wheel Removal

- Remove the right retaining ring [C], and unscrew the axle nut [D].
- Remove the left retaining ring [E], and pull out the axle [F].
- Loosening of the right and left clamp bolts are not needed.

CAUTION

Loosening of the right and left clamp bolts may cause misalignment of the right and left chain adjuster.

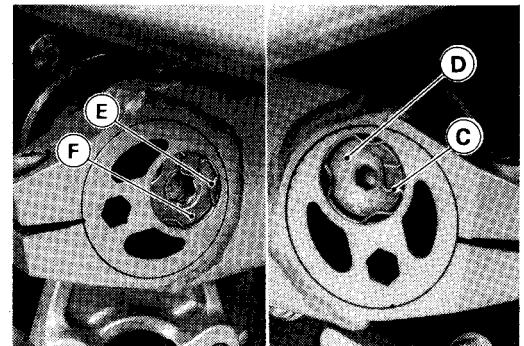

- Disengage the drive chain from the rear sprocket toward the left, and remove the rear wheel.

CAUTION

Do not lay the wheel on the ground with the disc facing down. This can damage or warp the disc. Place blocks under the wheel so that the disc does not touch the ground.

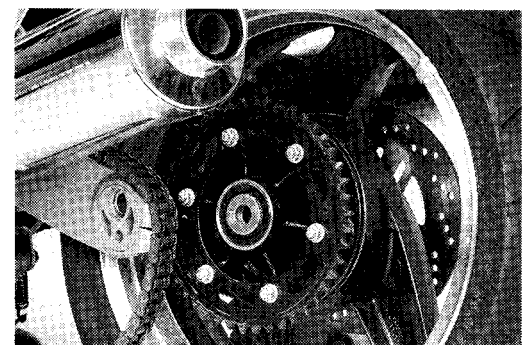

9-6 WHEELS / TIRES

Rear Wheel Installation Notes

- Engage the drive chain with the rear sprocket, and install the rear wheel.
- Insert the axle from the left side of the wheel, and tighten it.

Torque – Rear Axle Nut: 110 N-m (11.0 kg-m, 80 ft-lb)

- Install the rear brake caliper (see Brakes chapter).
- Adjust the drive chain slack after installation (see Final Drive chapter).
- Check the rear brake.

⚠ WARNING

Do not attempt to drive the motorcycle until a full brake pedal is obtained by pumping the brake pedal until the pads are against the disc. The brake will not function on the first application of the pedal if this is not done.

Inspection

- Raise the front/rear wheel off the ground.

Special Tool – Jack: 57001-1238

- Spin the wheel lightly, and check for roughness or binding.
- ★ If roughness or binding is found, replace the hub bearings.
- Inspect the wheel for small cracks, dents, bending, or warp.
- ★ If there is any damage to the wheel, replace the wheel.
- Remove the wheel, and support it without the tire by the axle.
- Measure the rim runout, radial [A] and axial [B], with a dial gauge.
- ★ If rim runout exceeds the service limit, check the hub bearings.
- ★ If the problem is not due to the bearings, replace the wheel.

Rim Runout

**Service Limit: Axial 0.5 mm
Radial 0.8mm**

⚠ WARNING

Never attempt to repair a damaged wheel. If there is any damage besides wheel bearings, the wheel must be replaced to insure safe operational condition.

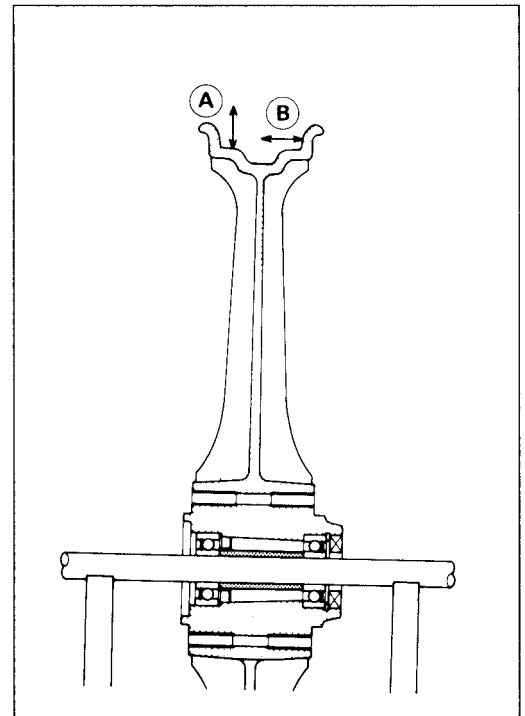

Axle Inspection

- Visually inspect the front and rear axle for damages.
- ★ If the axle is damaged or bent, replace it.
- Measure the axle runout with a dial gauge.
- ★ If axle runout exceeds the service limit, replace the axle.

Axle Runout/100 mm

**Standard: Under 0.05 mm
Service Limit: 0.2 mm**

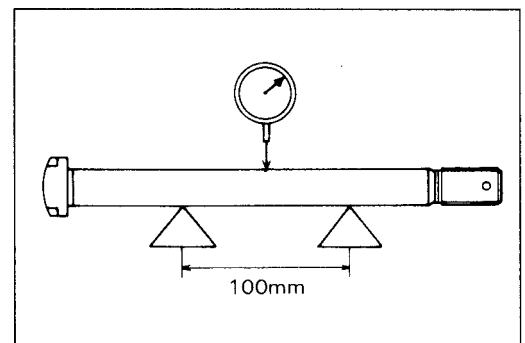

Wheel Balance

To improve stability and decrease vibration at high speed, the front and rear wheels must be kept balanced.

Check and balance the wheels when required, or when a tire is replaced with a new one.

Balance Inspection

- Remove the wheel.
- Support the wheel so that it can be spun freely.
- Spin the wheel lightly, and mark [A] the wheel at the top when the wheel stops.
- Repeat this procedure several times. If the wheel stops of its own accord in various positions, it is well balanced.
- ★ If the wheel always stops in one position, adjust the wheel balance.

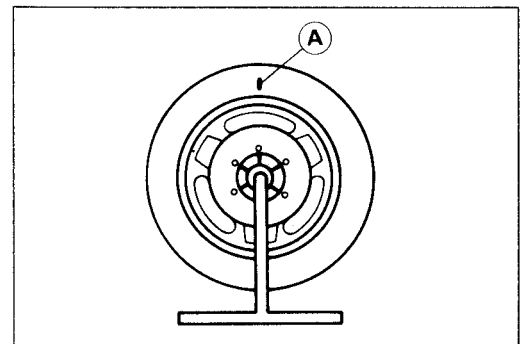

Balance Adjustment

- If the wheel always stops in one position, provisionally attach a balance weight [A] on the rim at the marking using adhesive tape.
- Rotate the wheel ¼ turn [B], and see whether or not the wheel stops in this position. If it does, the correct balance weight is being used.
- ★ If the wheel rotates and the weight goes up, replace the weight with the next heavier size. If the wheel rotates and the weight goes down, replace the weight with the next lighter size. Repeat these steps until the wheel remains at rest after being rotated ¼ turn.
- Rotate the wheel another ¼ turn and then another ¼ turn to see if the wheel is correctly balanced.
- Repeat the entire procedure as many times as necessary to achieve correct wheel balance.
- Permanently install the balance weight.

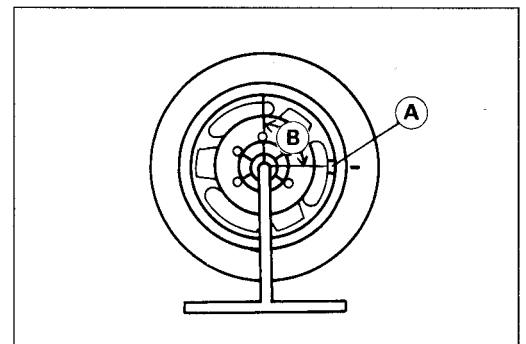

Balance Weight

Part Number	Weight(grams)
41075-1014	10
41075-1015	20
41075-1016	30

Balance Weight Installation

- Check if the weight portion has any play on the clip plate.
- ★ If it does, discard it.

▲ WARNING

If the balance weight has any play on the rim, the clip of the weight has been stretched. Replace the loose balance weight. Do not reuse used balance weight. Unbalanced wheels can create an unsafe riding condition.

9-8 WHEELS / TIRES

- Lubricate the balance weight blade, tire bead, and rim flange with a soap and water solution or rubber lubricant. This helps the balance weight slip onto the rim flange.

CAUTION

Do not lubricate the tire bead with engine oil or petroleum distillates because they will deteriorate the tire.

- Install balance weight at both sides of the rim flange when required total weight exceeds 40 g as shown.
- The balance weight lower than 30 g can be installed at either sides of the rim flange.

Required Total Weight	Weight Selection	
	One Side	Other Side
90 g	30 g × 2	30 g
80 g	30 g + 20 g	30 g
70 g	20 g × 2	30 g
60 g	30 g	30 g
50 g	20 g	30 g
40 g	20 g	20 g
30 g	20 g or (30 g)	10 g or (-)
20 g	10 g or (20 g)	10 g or (-)
10 g	10 g	-

- Install the balance on the rim.
- Slip the weight on the rim flange by pushing or lightly hammering the weight in the direction shown in the figure.
- Check that the blade and weight seat fully on the rim flange, and that the clip is hooked over the rim ridge and reaches rim flat portion.

Installing Balance Weight

- Press or lightly hammer the weight in.

- Installation completed

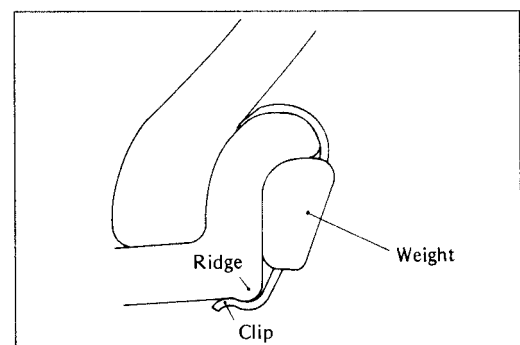
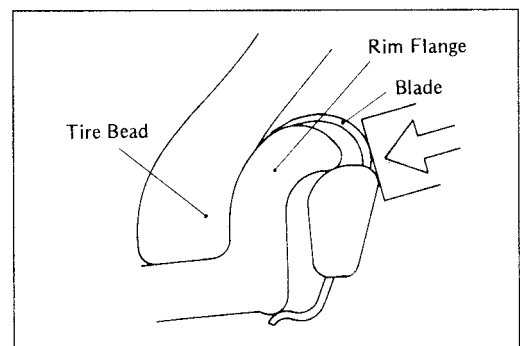

Balance Weight Removal

(a) When the tire is not on the rim.

- Push the blade portion toward the outside with a regular tip screw driver, and slip the weight off the rim flange.
- Discard the used balance weight.

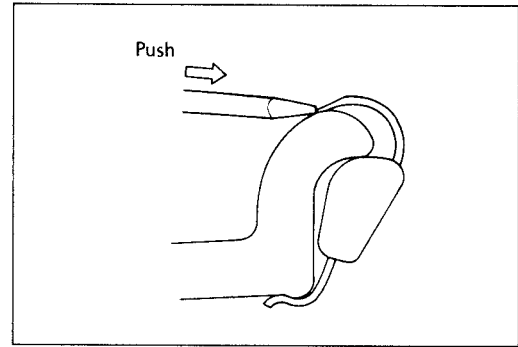

(b) When the tire is on the rim.

- Pry the balance weight off the rim flange using a regular tip screw driver as shown in the figure.
- Insert a tip of the screw driver between the tire bead and weight blade until the end of the tip reaches the end of the weight blade.
- Push the driver grip toward the tire so that the balance weight slips off the rim flange.
- Discard the used balance weight.

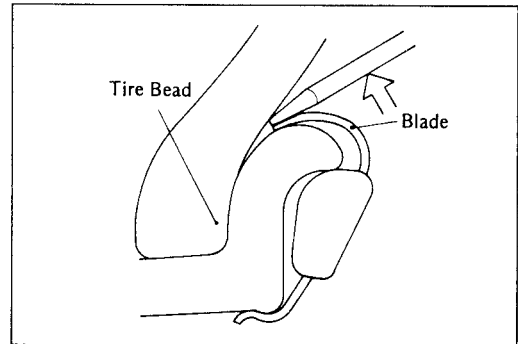

Air Pressure Inspection/Adjustment

- Measure the tire air pressure with an air pressure gauge [A] when the tires are cold.
- ★ Adjust the tire air pressure according to the specifications if necessary.

Air Pressure (when cold)

Front	Up to 183 kg (404 lb)	290 kPa (2.9 kg/cm ² , 41 psi)
Rear	Up to 183 kg (404 lb)	290 kPa (2.9 kg/cm ² , 41 psi)

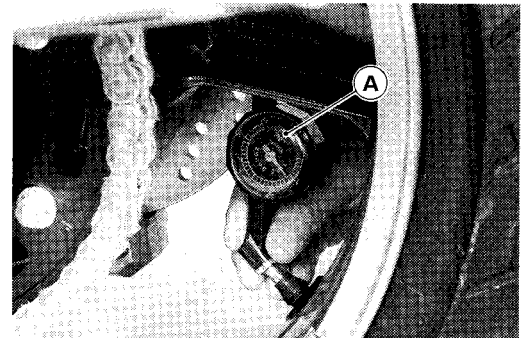

Inspection

As the tire tread wears down, the tire becomes more susceptible to puncture and failure. An accepted estimate is that 90% of all tire failures occur during the last 10% of tread life (90% worn). So it is false economy and unsafe to use the tires until they are bald.

- Remove any imbedded stones or other foreign particles from the tread.
- Visually inspect the tire for high spots indicate internal damage, requiring tire replacement.
- Visually inspect the tire for cracks and cuts, replacing the tire in case of damage. Swelling or high spots indicate internal damage, requiring tire replacement.
- Measure the tread depth at the center of the tread with a depth gauge [A]. Since the tire may wear unevenly, take measurement at several places.

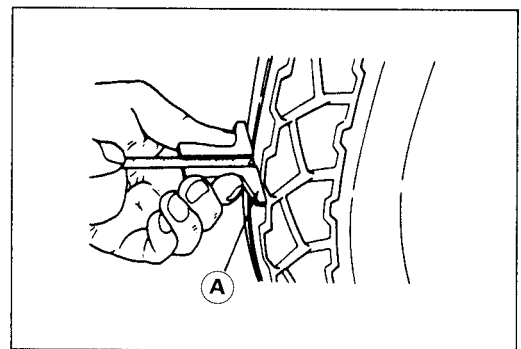

★ If any measurement is less than the service limit, replace the tire.

Tread Depth

Front:

Standard: 3.4 mm
Service Limit: 1 mm

Rear:

Standard: 5.8 mm
Service Limit: 2 mm(Up to 130 km/h)
 3 mm(Over 130 km/h)

9-10 WHEELS / TIRES

⚠ WARNING

To ensure safe handling and stability, use only the recommended standard tires for replacement, inflated to the standard pressure.

NOTE

○ Check and balance the wheel when a tire is replaced with a new one.

Standard Tire

Front: see Specifications

Rear: see Specifications

Installation

- Inspect the rim and tire, and replace them if necessary.
- Clean the sealing surfaces of the rim and tire, and smooth the sealing surfaces of the rim with a fine emery cloth if necessary.
- Remove the air valve and discard it.

CAUTION

Replace the air valve whenever the tire is replaced.
Do not reuse the air valve.

- Install a new valve in the rim.
- Remove the valve cap, lubricate the stem seal [A] with a soap and water solution or rubber lubricant, and pull the valve stem through the rim from the inside out until it snaps into place.

CAUTION

Do not use engine oil or petroleum distillates to lubricate the stem because they will deteriorate the rubber.

A. Valve Cap
B. Valve Core

C. Stem Seal
D. Valve Stem

E. Valve Seat
F. Valve Opened

- Apply a soap and water solution, or rubber lubricant to the rim flange and tire beads.
- Check the tire rotation mark on the front and rear tires and install them on the rim accordingly.

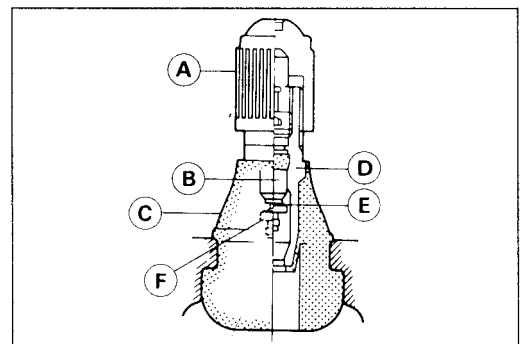
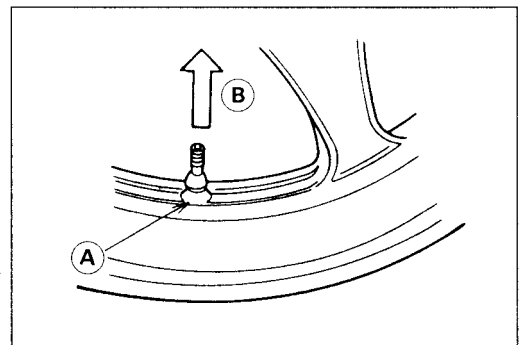

NOTE

○ The direction of the tire rotation [A] is shown by an arrow [B] on the tire sidewall.

- Position the tire on the rim so that the valve is at the tire balance mark (the chalk mark made during removal, or the yellow paint mark on a new tire).
- Install the tire bead over the rim flange with a tire changer.

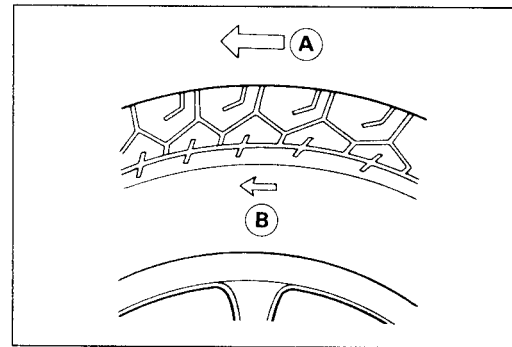

- Lubricate the tire beads and rim flanges with a soap and water solution or rubber lubricant to help seat the tire beads in the sealing surfaces of the rim while inflating the tire.
- Center the rim in the tire beads, and inflate the tire with compressed air until the tire beads seat in the sealing surfaces.

▲ WARNING

Be sure to install the valve core whenever inflating the tire, and do not inflate the tire to more than 400 kPa(4.0 kg/cm², 57 psi). Overinflation can explode the tire with possibility of injury and loss of life.

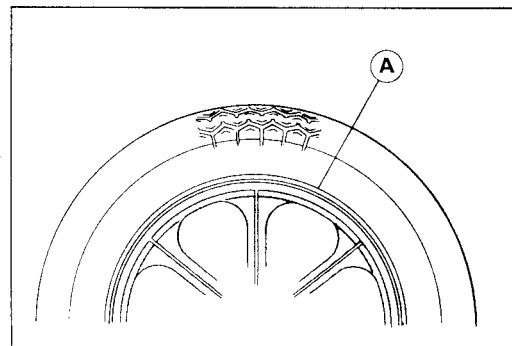

- Check to see that the rim lines [A] on both sides of the tire sidewalls are parallel with the rim flanges.
- ★ If the rim flanges and tire sidewall rim lines are not parallel, remove the valve core.
- Lubricate the rim flanges and tire beads.
- Install the valve core and inflate the tire again.
- After the tire beads seat in the rim flanges, check for air leaks.
- Inflate the tire slightly above standard inflation.
- Use a soap and water solution or submerge the tire, and check for bubbles that would indicate leakage.
- Adjust the air pressure to the specified pressure (see Tire Inspection).
- Install the brake disc(s) so that the disc rotation mark aligns with the tire rotation.
- Adjust the wheel balance.

Repair

Currently two types of repair for tubeless tires have come into wide use. One type is called a temporary (external) repair which can be carried out without removing the tire from the rim, and the other type is called permanent (internal) repair which requires tire removal. It is generally understood that higher running durability is obtained by permanent (internal) repairs than by temporary (external) ones. Also, permanent (internal) repairs have the advantage of permitting a thorough examination for secondary damage not visible from external inspection of the tire. For these reasons, Kawasaki does not recommend temporary (external) repair. Only appropriate permanent (internal) repairs are recommended. Repair methods may vary slightly from make to make. Follow the repair methods indicated by the manufacturer of the repair tools and materials so that safe results can be obtained.

9-12 WHEELS / TIRES

Hub Bearing

Removal

- Remove the wheel, and take out the following.
 - Collars
 - Coupling (out of rear hub)
 - Grease Seals
 - Circlips

Special Tool – Inside Circlip Pliers: 57001-143

Speedometer Gear Drive (out of front hub) [B]

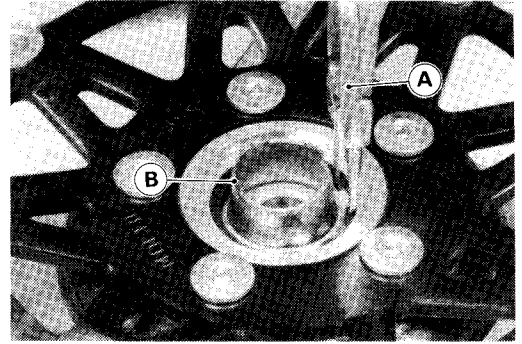

- Take the bearings [A] out of the hub.

CAUTION

Do not lay the wheel on the ground with the disc facing down. This can damage or warp the disc. Place blocks under the wheel so that the disc does not touch the ground.

Special Tools – Bearing Remover Shaft: 57001-1265

Bearing Remover Head, $\Phi 15 \times \Phi 17$: 57001-1267

Bearing Remover Head, $\Phi 20 \times \Phi 22$: 57001-1293

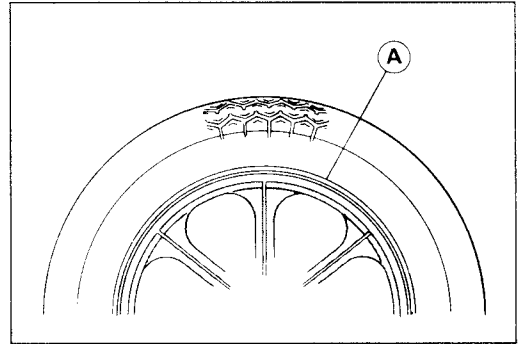

Installation Notes

- Before installing the wheel bearings, blow any dirt or foreign particles out of the hub with compressed air to prevent contamination of the bearings.
- Replace the bearings with new ones.
- Press in the bearings until they are bottomed.

Special Tool – Bearing Driver Set: 57001-1129 [A]

NOTE

○ Install the bearings so that the marked side faces out.

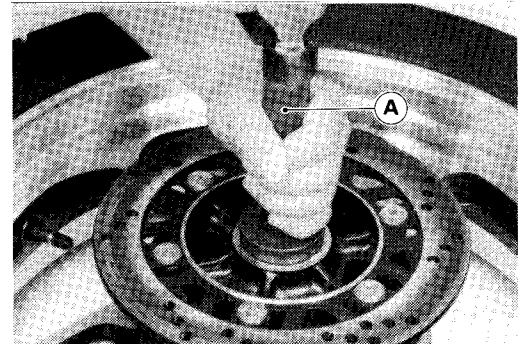

- Replace the circlips with new ones.

Special Tool – Inside Circlip Pliers: 57001-143

- Replace the grease seals with new ones.
- Press in the grease seals so that seal surface is flush with the end of the hole.
- Apply high temperature grease to the grease seal lips.

Special Tool – Bearing Driver Set: 57001-1129 [A]

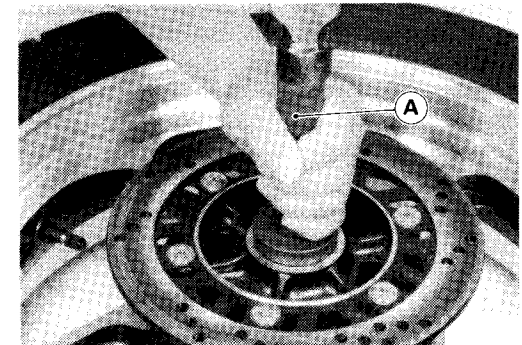

Inspection

NOTE

○ It is not necessary to remove any bearings for inspection. If any bearings are removed, they will need to be replaced with new ones.

- Spin it by hand to check its condition.
- ★ If it is noisy, does not spin smoothly, or has any rough spots, it must be replaced.
- Examine the bearing seal for tears or leakage.
- ★ If the seal is torn or is leaking, replace the bearing.

Speedometer Gear Housing

Disassembly and Assembly

NOTE

○ *It is recommended that the assembly be replaced rather than attempting to repair the components.*

- Install the speedometer gear housing so that it fits in the speedometer gear drive notches (see Front Wheel Installation Notes).

Lubrication

- Clean and grease [A] the speedometer gear housing [B] in accordance with the Periodic Maintenance Chart,

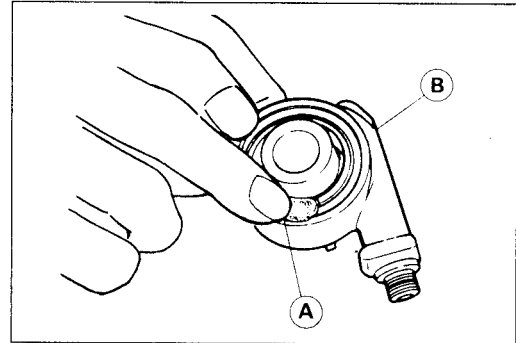

Final Drive

Table of Contents

Exploded View	10-2
Specifications	10-3
Drive Chain.....	10-4
Slack Inspection.....	10-4
Wheel Alignment Adjustment	10-4
Wear Inspection	10-5
Lubrication	10-6
Drive Chain Removal.....	10-7
Installation Notes	10-7
Sprocket, Coupling	10-8
Engine Sprocket Removal	10-8
Engine Sprocket Installation Notes	10-8
Rear Sprocket Removal	10-8
Rear Sprocket Installation.....	10-9
Sprocket Warp Inspection	10-9
Coupling Bearing Removal	10-9
Coupling Bearing Installation Notes	10-9
Coupling Installation Notes.....	10-10

10-2 FINAL DRIVE

Exploded View

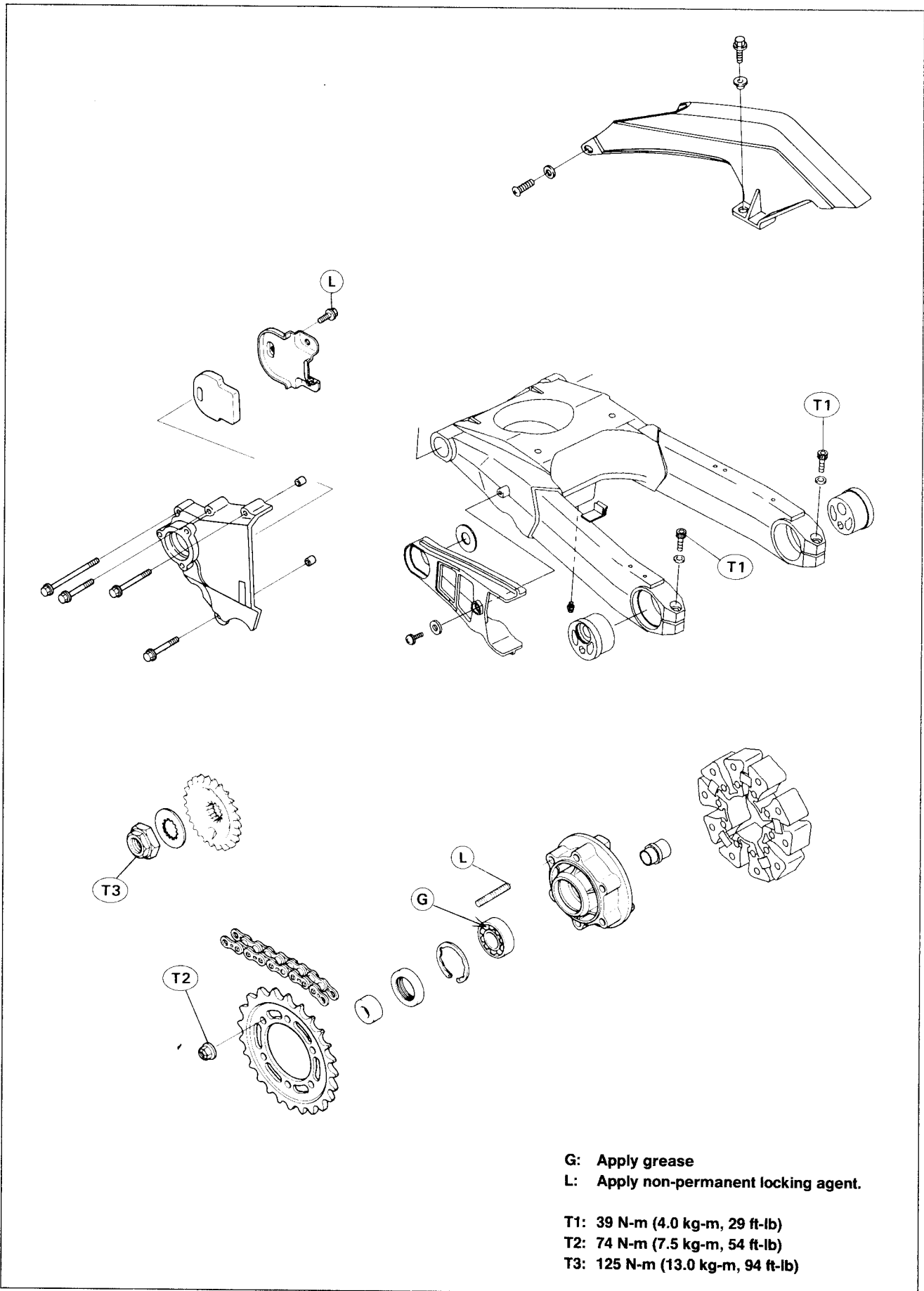

G: Apply grease
L: Apply non-permanent locking agent.

T1: 39 N-m (4.0 kg-m, 29 ft-lb)
T2: 74 N-m (7.5 kg-m, 54 ft-lb)
T3: 125 N-m (13.0 kg-m, 94 ft-lb)

Specifications

Item	Standard	Service Limit
Drive Chain: Make type Chain slack 20 link length	Enuma, endless EK50ZV-X 110 Link 35 ~ 40 mm 317.5 ~ 318.2 mm	--- --- Less than 35 mm, or more than 45 mm 323 mm
Sprockets: Rear sprocket warp	---	0.5 mm

10-4 FINAL DRIVE

Drive Chain

Slack Inspection

NOTE

- Check the slack with the motorcycle setting on its center stand.
- Clean the chain if it is dirty, and lubricate it if it appears dry.
- Check the wheel alignment (see Wheel Alignment Inspection).
- Rotate the rear wheel to find the position where the chain is tightest.
- Measure the vertical movement (chain slack) [A] midway between the sprockets.
- ★ If the chain slack exceeds the standard, adjust it.

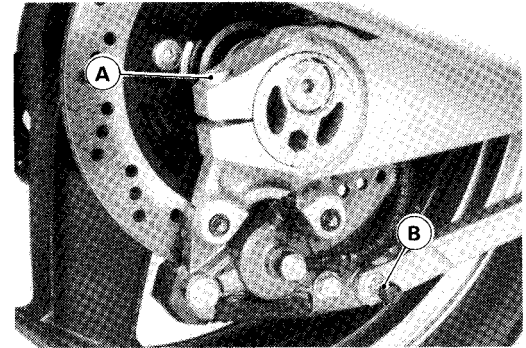
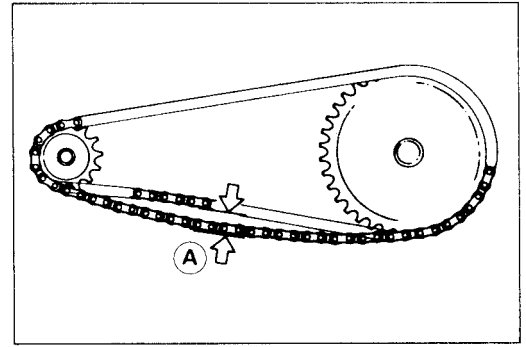

- Chain Slack**
- Standard:** 35 ~ 40 mm
- Usable Range:** Less than 35 mm, or more than 45 mm
- Loosen the left and right chain adjuster clamp bolts [A].
 - Loosening of the torque link nut [B] is not needed.

- Turn the chain adjusters [B] forward or rearward with an Allen wrench [A] until the drive chain has the correct amount of chain slack.
- The left and right notches on the swing arm should point to the same marks or positions on the left and right adjusters.

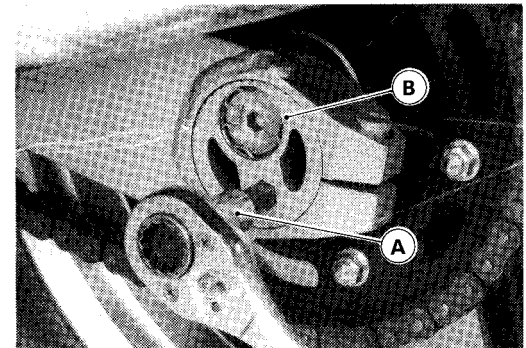

⚠ WARNING

Misalignment of the wheel will result in abnormal wear, and may result in an unsafe riding condition.

- Tighten the chain adjuster clamp bolts.
- Torque – Chain Adjuster Clamp Bolts : 39 N-m(4.0 kg-m, 29 ft-lb)**

Wheel Alignment Adjustment

- Set the motorcycle up on its center stand.
- Check to see if wheel alignment is properly adjusted. The left and right notches [A] on the swing arm should point to the same marks [B] or positions on the left and right adjusters.

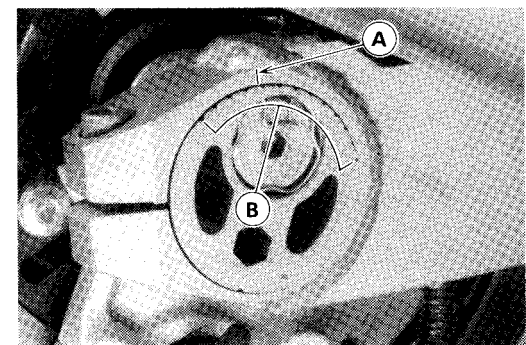

- If not, adjust the wheel alignment.
- Remove the left retaining ring [A].
- Loosen the rear axle shaft [B].
- Loosen both left and right chain adjuster clamp bolts [C].
- Loosening of the require link nut is not required.

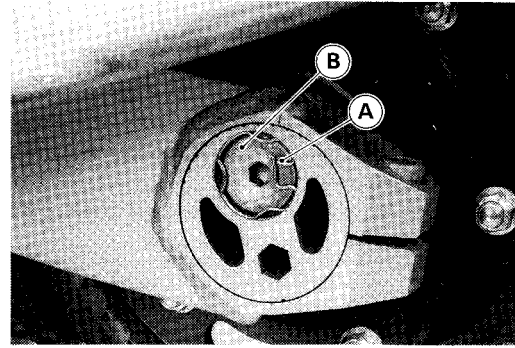

- Turn the chain adjusters together to position the triangle mark [A] on both left and right chain adjusters at the parting line [B] of the swing arm end.
- Tighten both left and right chain adjuster clamp bolts [C].
- Tighten the rear axle shaft [D].

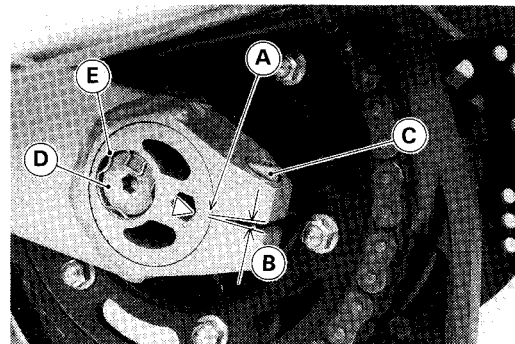

Torque – Axle Nut : 110 N-m (11.0 kg-m, 80 ft-lb)

- Insert the retaining ring [E] to secure the axle shaft.

- Loosen the chain adjuster clamp bolts [A] again, then turn the chain adjuster so that the left and right notches on the swing arm point to the same marks [B] or positions on the left and right adjuster.
- Tighten both chain adjuster clamp bolt.

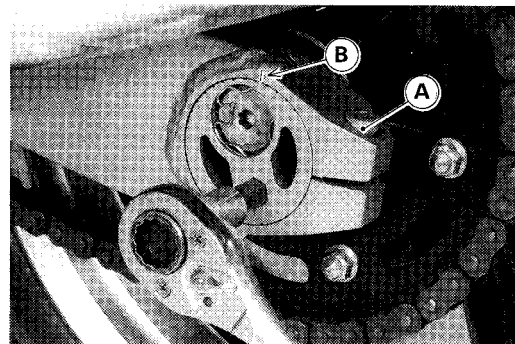

Torque – Chain Adjuster Clamp Bolts: 39 N-m (4.0 kg-m, 29 ft-lb)

▲WARNING

If the axle nut or clamp bolts are not securely tightened or the retaining ring is not installed, an unsafe riding condition may result.

Wear Inspection

- Remove:
 - Chain Cover
- Rotate the rear wheel to inspect the drive chain for damaged rollers, and loose pins and links.
- ★ If there is any irregularity, replace the drive chain.
- ★ Lubricate the drive chain if it appears dry.
- Stretch the chain taut by hanging a 98 N (10 kg, 20 lb) weight [A] on the chain.

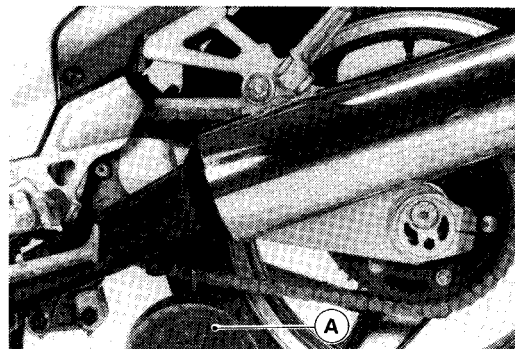

- Measure the length of 20 links [A] on the straight part of the chain from the pin center of the 1st pin to the pin center of the 21st pin. Since the chain may wear unevenly, take measurements at several places.

- ★ If any measurements exceed the service limit, replace the chain. Also, replace the front and rear sprockets when the drive chain is replaced.

Chain 20-link Length

Standard: 317.5 ~ 318.2 mm
Service Limit: 323 mm

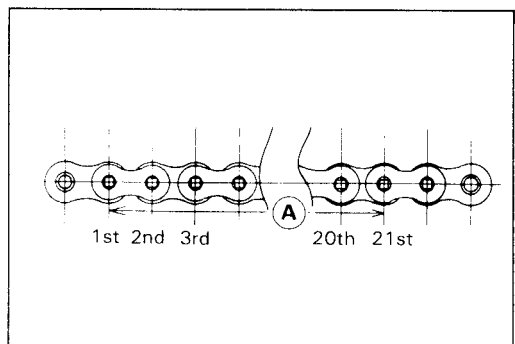

⚠WARNING

If the drive chain wear exceeds the service limit, replace the chain or an unsafe riding condition may result. A chain that brakes or jumps off the sprockets could snag on the engine sprocket or lock the rear wheel, severely damaging the motorcycle and causing it to go out of control.

For safety, use only the standard chain. It is an endless type and should not be cut for installation.

Standard Chain

Mark: ENUMA
Type: EK50ZV-X
Link: 110 Link

Lubrication

The chain should be lubricated with a lubricant which will both prevent the exterior from racing and also absorb shock and reduce friction in the interior of the chain. An effective, good quality lubricant specially formulated for chains is best for regular chain lubrication. If a special lubricant is not available, a heavy oil such as SAE 90 is preferred to a lighter oil because it will stay on the chain longer and provide better lubrication.

- If the chain appears especially dirty, clean it before lubrication.

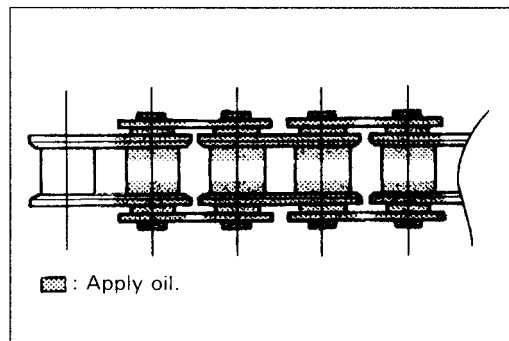

CAUTION

The O-rings between the side plates seal in the lubricant between the pin and the bushing. To avoid damaging the O-rings and resultant loss of lubricant, observe the following rules.

Use only kerosene or diesel oil for cleaning an O-ring drive chain.

Any other cleaning solution such as gasoline or trichloroethylene will cause deterioration and swelling of the O-ring.

Immediately blow the chain dry with compressed air after cleaning.

Complete cleaning and drying the chain within 10 minutes.

- Apply oil to the sides of the rollers so that oil will penetrate to the rollers and bushings. Apply the oil to the O-rings so that the O-rings will be coated with oil. Wipe off any excess oil.

Drive Chain Removal

- Remove the following.
 - Clutch Slave Cylinder (see Clutch chapter)
 - Sprocket Cover
 - Engine Sprocket Nut

NOTE

- When loosening the engine sprocket nut [A], insert the steel rod into the rod hole [B] to hold the sprocket.

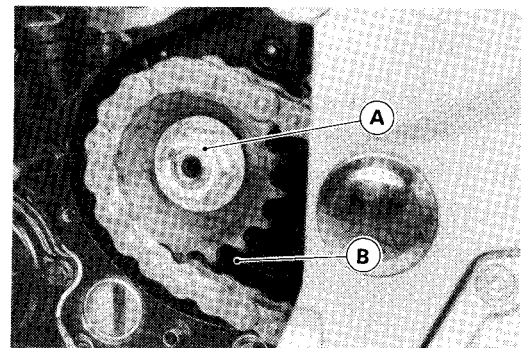

Rear Wheel (see Wheels/Tires)
Swing Arm (see Suspension chapter)

- Pull the engine sprocket off the output shaft with the drive chain, and then separate them.

Installation Notes

- Adjust the chain slack after installing the chain.

10-8 FINAL DRIVE

Sprocket, Coupling

Engine Sprocket Removal

- Loosen the drive chain.
- Remove the following.
 - Clutch Slave Cylinder (see Clutch chapter)
 - Sprocket Cover
 - Engine Sprocket nut

NOTE

- When loosening the engine sprocket nut [A], insert the steel rod into the rod hole [B] to hold the sprocket.

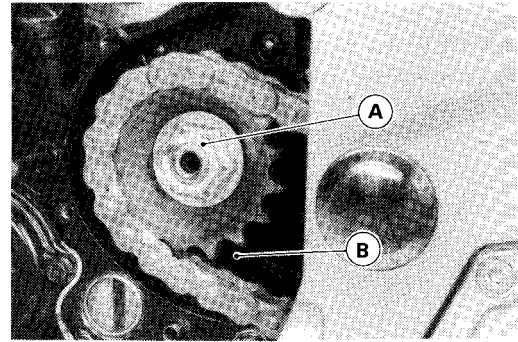

- Remove the drive chain from the rear sprocket.

NOTE

- If it is difficult to remove the drive chain from the rear sprocket, remove the rear axle (see Wheels/Tires chapter).

- Pull the engine sprocket off the output shaft.

Engine Sprocket Installation Notes

- Install the engine sprocket onto the output shaft with the drive chain engaged.
- After torquing the engine sprocket nut [A], bend the one side [B] of the washer over the nut.

NOTE

- Tighten the nut while applying the rear brake.

Torque – Engine Sprocket Nut : 125 N-m (13.0 kg, 94 ft-lb)

- Adjust the drive chain slack after installing the sprocket (see Drive Chain Slack Adjustment).

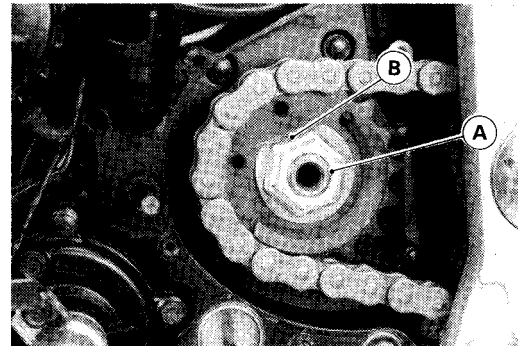

Rear Sprocket Removal

- Remove the rear wheel (see Wheel/Tires chapter).

CAUTION

Do not lay the wheel on the ground with the disc facing down. This can damage or warp the disc. Place blocks under the wheel so the disc does not touch the ground.

- Remove the rear sprocket nuts.
- Remove the rear sprocket.

Rear Sprocket Installation

- Installation is the reverse of removal. Note the following.
- Install the sprocket facing the tooth number marking outward [A].

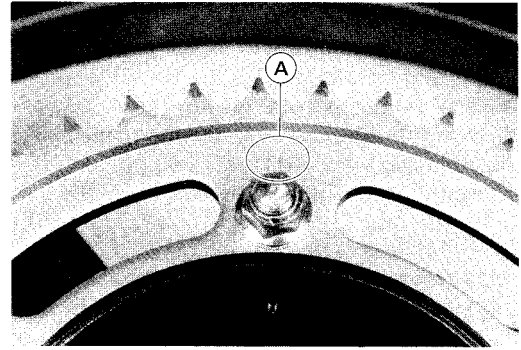

- Tighten the rear sprocket nuts.
- Torque – Rear Sprocket Nut : 74 N-m (7.5 kg-m, 54 ft-lb)**
- Install the rear wheel (see Wheels/ Tires chapter).

Sprocket Warp Inspection

- Set the motorcycle on its center stands.
- Set a dial gauge [A] against the rear sprocket [B] near the teeth as shown, and rotate [C] the rear wheel to measure the sprocket runout (warp). The difference between the highest and lowest dial gauge readings is the amount of runout (warp).
- ★ If the runout exceeds the service limit, replace the rear sprocket.

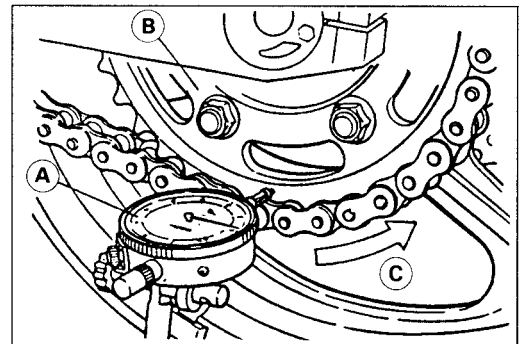

Rear Sprocket Warp

Standard: Under 0.4 mm
Service Limit: 0.5 mm

Coupling Bearing Removal

- Remove the coupling.
- Remove the circlip.
- Special Tool – Inside Circlip Pliers: 57001-143**
- Remove the bearing by tapping from the wheel side.
- Special Tool – Bearing Driver Set: 57001-1129 [A]**

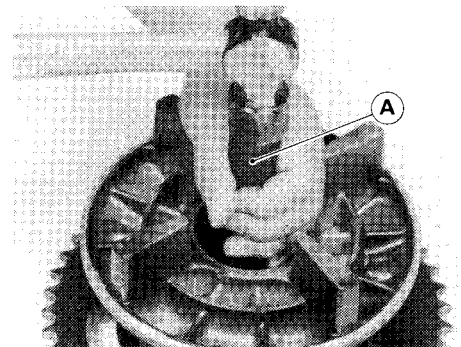

Coupling Bearing Installation Notes

- Replace the bearing with a new one.
- Press in the bearing until it is bottomed.
- Special Tool – Bearing Driver Set: 57001-1129**
- Pack the bearing with high temperature grease.
- Replace the circlip with a new one.
- Special Tool – Inside Circlip Pliers: 57001-143 [A]**

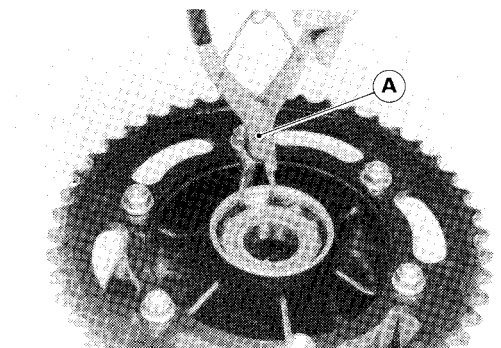

10-10 FINAL DRIVE

Coupling Installation Notes

- Use an oilless solvent to thoroughly clean any oil off the damper [C], hub, and coupling [A].
- Install the damper into the rear hub.
- Use a little adhesive to fasten the spacers [B] into the coupling during assembling.
- Insert the coupling into the rear hub.

NOTE

- *Always use a soap and water solution to ease inserting the coupling into the hub. Never use such lubricant that leaves oily residue.*

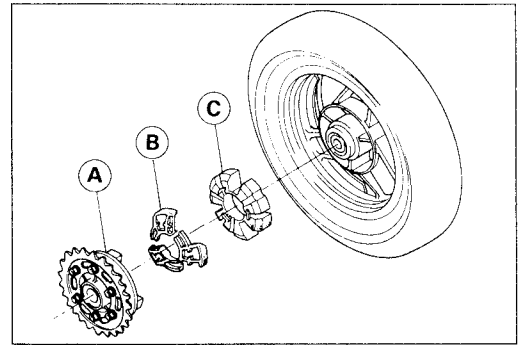

Brakes

Table of Contents

Exploded View	11-2
Specifications	11-4
Brake Pedal	11-5
Brake Pedal Position Adjustment.....	11-5
Rear Brake Light Switch Adjustment.....	11-5
Calipers.....	11-6
Front Caliper Removal	11-6
Rear Caliper Removal	11-6
Caliper Installation	11-6
Disassembly Notes.....	11-7
Assembly Notes	11-7
Brake Pads	11-9
Removal	11-9
Installation Notes	11-9
Lining Wear.....	11-9
Master Cylinder.....	11-10
Front Master Cylinder Installation.....	11-10
Rear Master Cylinder Removal Note.....	11-10
Rear Master Installation Notes.....	11-10
Inspection and Adjustment after Installation	11-11
Disassembly.....	11-11
Assembly Notes	11-11
Inspection(Visual Inspection)	11-12
Brake Disc	11-13
Wear	11-13
Warp.....	11-13
Brake Fluid	11-14
Level Inspection.....	11-14
Change.....	11-14
Bleeding the Brake Line	11-15

11-2 BRAKES

Exploded View

- 1. Front Brake Light Switch
- 2. Rear Brake Light Switch

G: Apply grease.

S: Follow the specified tightening sequence.

T1: 5.9 N-m (0.60 kg-m, 52 in-lb)

T2: 7.8 N-m (0.80 kg-m, 69 in-lb)

T3: 8.8 N-m (0.90 kg-m, 78 in-lb)

T4: 11 N-m (1.1 kg-m, 95 in-lb)

T5: 18 N-m (1.8 kg-m, 13.0 ft-lb)

T6: 21 N-m (2.1 kg-m, 15.0 ft-lb)

T7: 23 N-m (2.3 kg-m, 16.5 ft-lb)

T8: 25 N-m (2.5 kg-m, 18.0 ft-lb)

T9: 34 N-m (3.5 kg-m, 25 ft-lb)

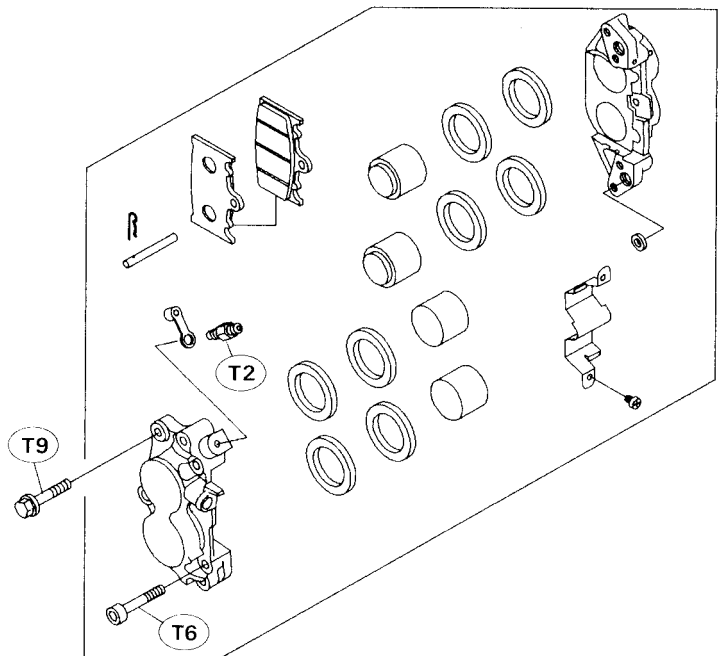
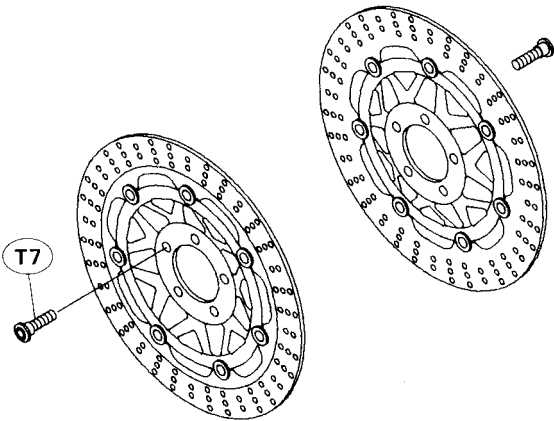
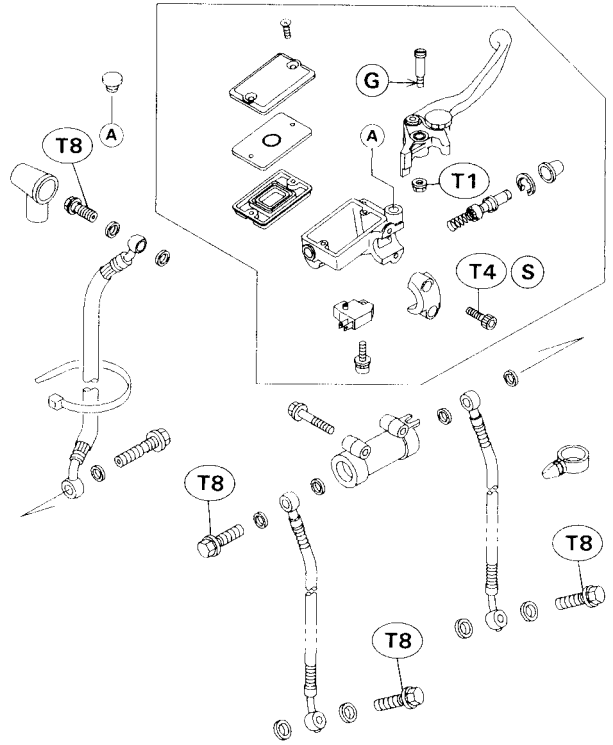

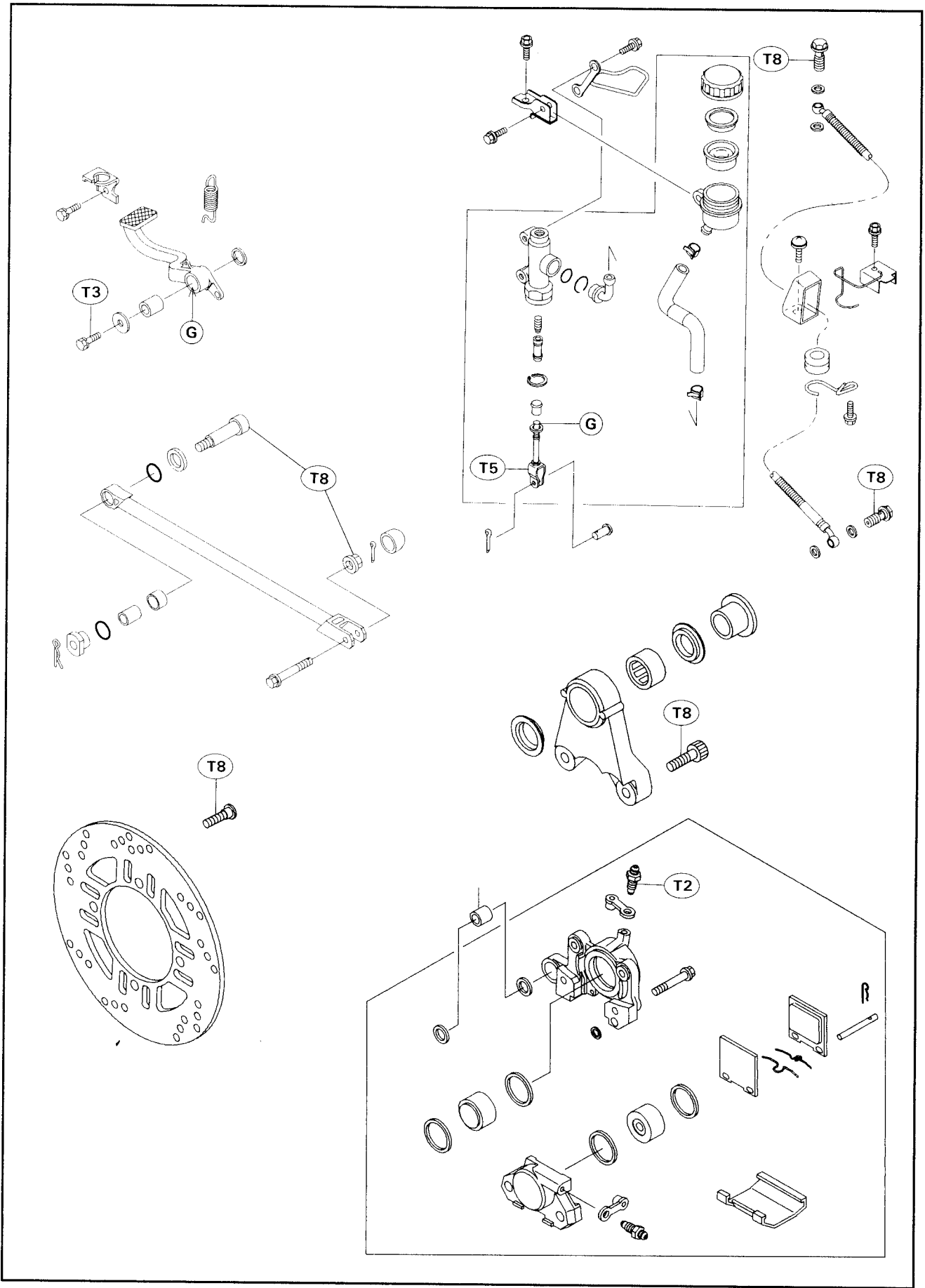

11-4 BRAKES

Specifications

Item	Standard	Service Limit
Brake Pedal: Brake pedal position Rear brake light switch	45 mm below top of footpeg ON after about 10 mm pedal travel	--- ---
Brake Pad: Pad lining thickness: Front Rear	4.0 mm 4.0 mm	1 mm 1 mm
Brake Discs: Disc thickness: Front Rear Disc runout	4.8 ~ 5.1 mm 5.8 ~ 6.1 mm ---	4.5 mm 5.0 mm 0.3 mm
Brake Fluid: Grade Brand (recommended)	D.O.T.4. Castrol Girling-Universal Castrol GT(LMA) Castrol Disc Brake Fluid Check Shock Premium Heavy Duty	--- --- --- --- ---

Brake Pedal

Brake Pedal Position Adjustment

- Check that the brake pedal [B] is in the correct position.

Pedal Position [A]

Standard: About 45 mm below top of footpeg.

[C] Footpeg

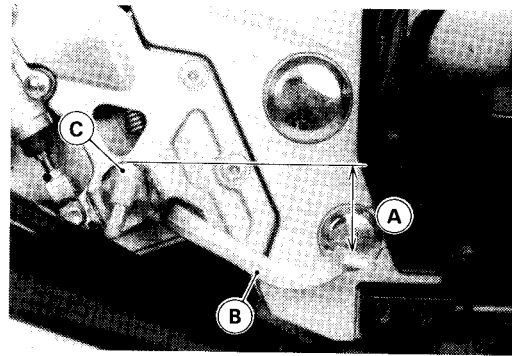

NOTE

- Usually it's not necessary to adjust the pedal position, but always adjust it when the master cylinder [B] is disassembled.
- If the pedal position cannot be adjusted by turning the clevis [D], the brake pedal may be deformed or incorrectly installed.
- When the brake pedal is in its rest position, measure the length (A) indicated in the figure.
- ★ If the length (A) is not within the specified length, adjust a lock nut (C).

Length (A)

Standard: 80 ± 1 mm

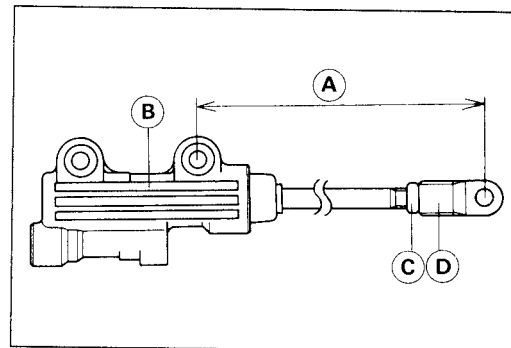

Rear Brake Light Switch Adjustment

- Check the operation of the rear brake light switch by depressing the brake pedal [A]. The brake light should go on after about 10 mm of pedal travel [B].

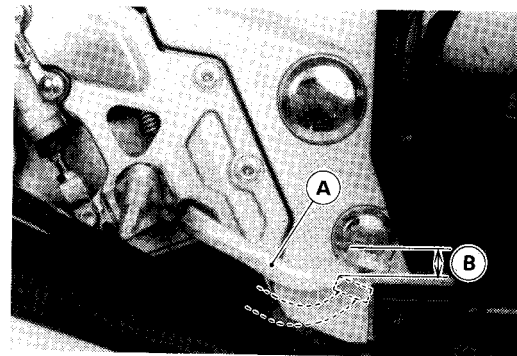

- ★ If it does not, adjust the brake light switch [A].
- Turn the adjusting nut [B] to adjust the switch.

[C] Light sooner.

[D] Light later.

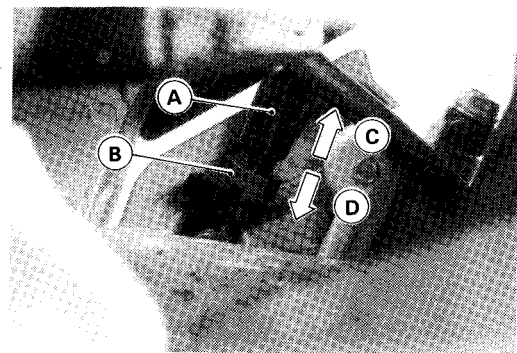

CAUTION

To avoid damaging the electrical connections inside the switch, be sure that the switch body does not turn during adjustment.

11-6 BRAKES

Calipers

Front Caliper Removal

- Remove the following if the caliper is to be removed from the vehicle completely.
Brake Hose Banjo Bolt (at the caliper)

CAUTION

Immediately wipe up any brake fluid that spills.

- Remove the following.
Caliper Mounting Bolts [C].

CAUTION

Do not loosen the caliper bolts. Take out only the caliper mounting bolts for caliper removal. Loosening the caliper bolts will cause brake fluid leakage.

[A] Banjo Bolt

Do not loosen the caliper bolts [B].

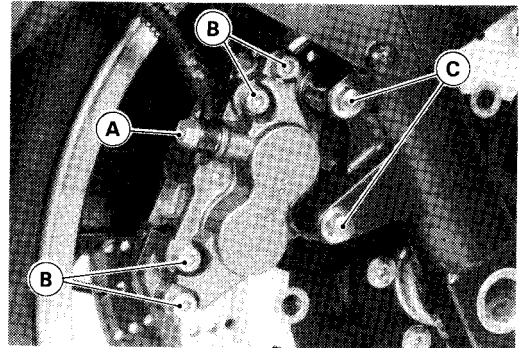

- ★ If the caliper is to be disassembled after removal and if compressed air is not available, remove the piston using the following steps before disconnecting the brake hose from the caliper.

- Remove the pads.
- Pump the brake lever to remove the caliper piston.

CAUTION

Immediately wipe up any brake fluid that spills.

Rear Caliper Removal

- Remove the rear caliper in the same way as the front caliper.

[A] Banjo Bolt [B] Caliper Mounting Bolts
[C] Torque Link Bolt

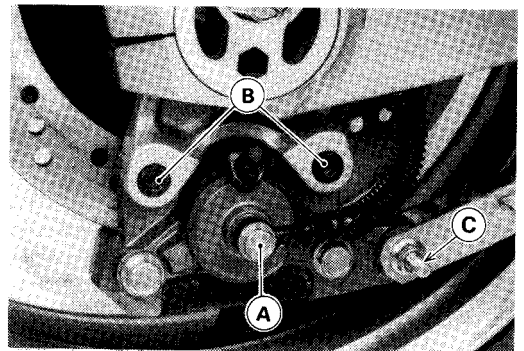

Caliper Installation

- Tighten the caliper mounting bolts.

Torque – Front Caliper Mounting Bolt : 34 N-m(3.5 kg-m, 25 ft-lb)

Rear Caliper Mounting Bolt : 25 N-m(2.5 kg-m, 18 ft-lb)

- Connect the brake hose to the caliper putting a new flat washer on each side of the brake hose fitting.
- Tighten the banjo bolt.

Torque – Banjo bolt : 25 N-m(2.5 kg-m, 18 ft-lb)

- Check the fluid level in the master cylinder (reservoir), and bleed the brake line (see Bleeding the Brake).
- Check the brake for weak braking power, brake drag, and fluid leakage.

▲WARNING

Do not attempt to drive the motorcycle until a full brake lever or pedal is obtained by pumping the brake lever or pedal until the pads are against the disc. The brakes will not function on the first application of the lever or pedal if this is not done.

Disassembly Notes

- To disassemble the front caliper, perform the following.
 - Remove the following.
 - Brake Pads
 - Caliper Bolts
 - Piston Insulators
 - Using compressed air, remove the pistons. One way to remove the pistons is as follows.

- Install a wooden board [C] more than 10 mm thick and a rubber gasket [B] on the caliper half as shown. Leave one of the oil passages open.

[A] Bolt and Nut [D] Oil Passage sealed by Rubber Gasket
 [E] Oil Passage

- Lightly apply compressed air [A] to the oil passage until the pistons hit the rubber gasket. Block the hose joint opening during this operation if the caliper half has opening.

[B] Cloth

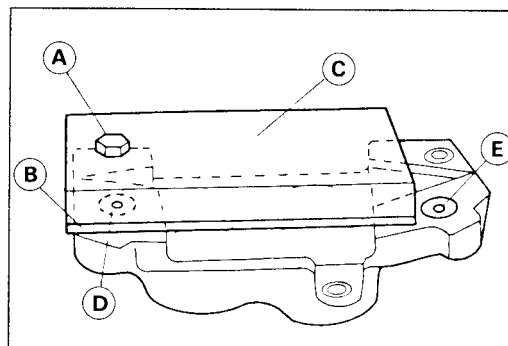

▲WARNING

To avoid serious injury, never place your fingers or palm inside the caliper opening. If you apply compressed air into the caliper, the piston may crush your hand or fingers.

Assembly Notes

- Apply brake fluid to the outside of the piston and the fluid seal, and push the piston into the cylinder by hand. Take care that neither the cylinder nor the piston skirt get scratched.
- Apply a thin coat of PBC (Poly Butyl Cuprysil) grease to the caliper holder shafts and holder holes. (PBC is a special high temperature, water-resistant grease).

11-8 BRAKES

- Tighten the front caliper mounting bolts.

Torque – Front Caliper Mounting Bolts : 34 N-m(3.5 kg-m, 25 ft-lb).

Brake Pads

Removal

- Remove the caliper (see Front or Rear Caliper Removal).
- Remove the following to remove the front caliper pads.
 - Screws [A]
 - Pad Spring [B]

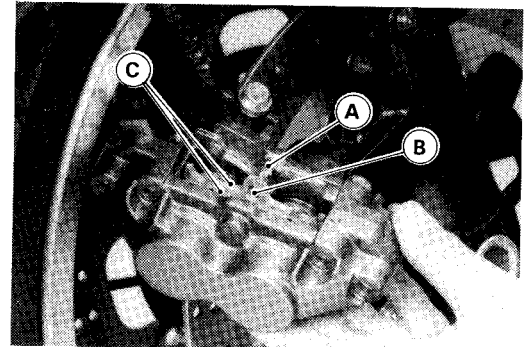
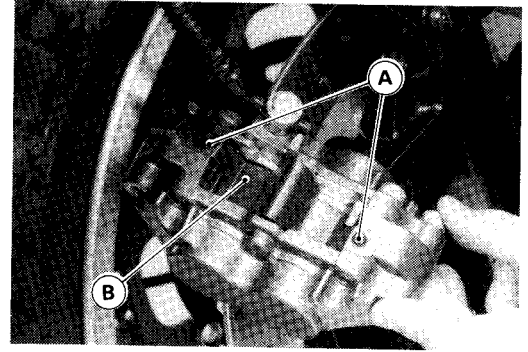

Clip [A]
Pad Pin [B]
Pads [C]

Installation Notes

- Push the caliper pistons in by hand as far as they will go.
- For the front caliper, the pad pin clip must be "outside" of the pads.

⚠ WARNING

Do not attempt to drive the motorcycle until a full brake lever or pedal is obtained by pumping the brake lever or pedal until the pads are against the disc. The brake will not function on the first application of the lever or pedal if this is not done.

Lining Wear

- ★ If the lining thickness of either pad is less than the service limit, replace both pads in the caliper as a set.

Pad Lining Thickness [A]

Standard: 4.0 mm
Service Limit [B]: 1 mm

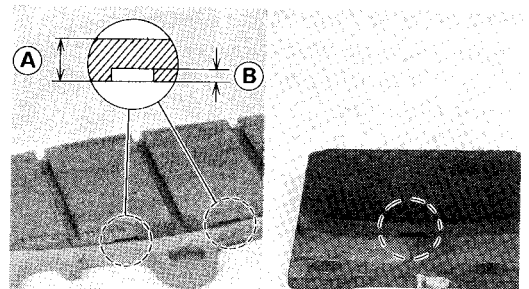

11-10 BRAKES

Master Cylinder

Front Master Cylinder Installation

- The Master cylinder clamp must be installed with the arrow mark upward[C].
- Torque the upper clamp bolt[A] first, and then the lower clamp bolts [B]. There will be a gap at the lower part of the clamp after tightening.

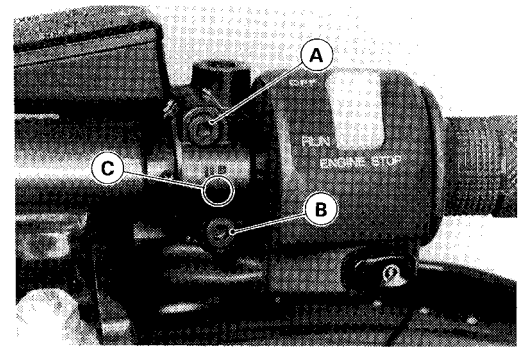

Torque – Upper/Lower Clamp Bolts : 11 N-m(1.1 kg-m, 95 in-lb)

- Use a new flat washer on each side of the brake hose fitting.
- Tighten the banjo bolts.

Torque – Banjo Bolts : 25 N-m(2.5 kg-m, 18 ft-lb)

Rear Master Cylinder Removal Note

- Remove the cotter pin[B] and then pull the joint pin[C] out of the push rod clevis[A] and brake pedal.

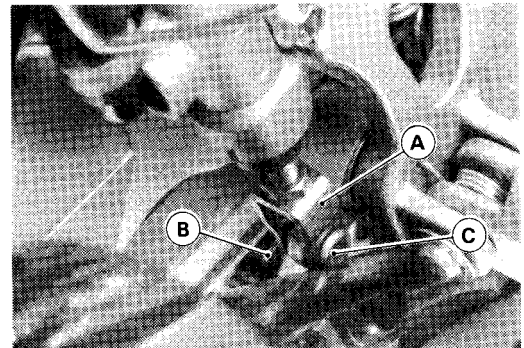

Rear Master Installation Notes

- Use a new flat washer on each side of the brake hose fitting. Be sure that the metal pipe is properly fitted into the projection[A] on the master cylinder.

[B] Metal Pipe

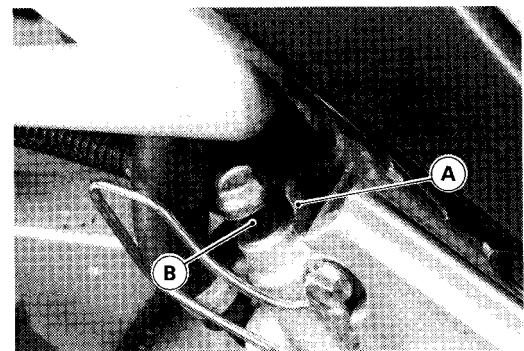

- Tighten the banjo bolts.

Torque – Banjo Bolts : 25 N-m(2.5 kg-m, 18 ft-lb)

- Tighten the rear master cylinder mounting bolts (2).

Torque – Master Cylinder Mounting Bolts : 23 N-m(2.3 kg-m, 16.5 ft-lb)

Inspection and Adjustment after Installation

- Check and adjust the following items after installation.
 - Brake Pedal Position
 - Rear Brake Light Switch Position
 - Brake Line Air Bleed
 - Brake Drag
 - Braking Power
 - Brake Fluid Leak

Disassembly

- Remove the following parts.
 - Dust Cover
 - Retainer[D]
 - Piston[C] with Secondary Cup [B]
 - Primary Cup [A]
 - Spring

CAUTION

Do not remove the secondary cup from the piston since removal will damage them.

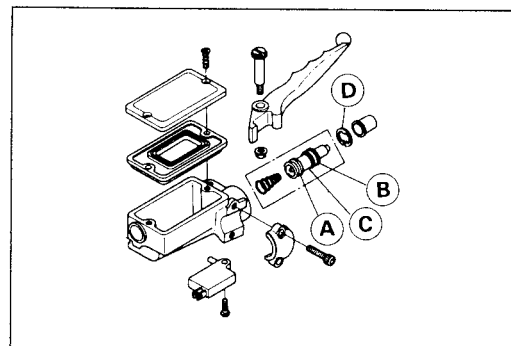
*Assembly Notes*

- Before assembly, clean all parts including the master cylinder with brake fluid or alcohol.

CAUTION

Except for the disc pads and disc, use only disc brake fluid, isopropyl alcohol, or ethyl alcohol for cleaning brake parts. Do not use any other fluid for cleaning these parts. Gasoline, engine oil, or any other petroleum distillate will cause deterioration of the rubber parts. Oil spilled on any part will be difficult to wash off completely, and will eventually deteriorate the rubber used in the disc brake.

- Apply brake fluid to the removed parts and to the inner wall of the cylinder.
- Take care not to scratch the piston or the inner wall of the cylinder.
- Tighten the brake lever pivot bolt and the locknut.
 - Torque – Brake Lever Pivot Bolt: 1.0 N-m (0.1 kg-m, 9 in-lb)**
 - Brake Lever Pivot Bolt Locknut : 5.9 N-m (0.6 kg-m, 52 in-lb)**

11-12 BRAKES

Inspection(Visual Inspection)

- Disassemble the front and rear master cylinders.
- Check that there are no scratches, rust or pitting on the inner wall of each master cylinder [A] and on the outside of each piston [B].
- ★ If a master cylinder or piston shows any damage, replace them.
- Inspect the primary [C] and secondary [D] cups.
- ★ If a cup is worn, damaged, softened (rotted), or swollen, the piston assembly should be replaced to renew the cups.
- ★ If fluid leakage is noted at the brake lever, the piston assembly should be replaced to renew the cups.

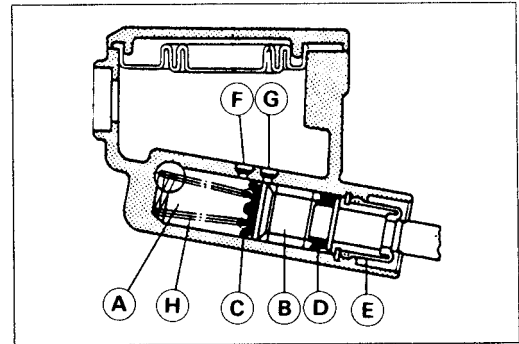

- Check the dust covers [E] for damage.
- ★ If they are damaged, replace them.
- Check that relief [F] and supply [G] ports are not plugged.
- ★ If the relief port becomes plugged, the brake pads will drag on the disc.
Blow the ports clean with compressed air.
- Check the piston return springs [H] for any damage.
- ★ If the springs are damaged, replace them.

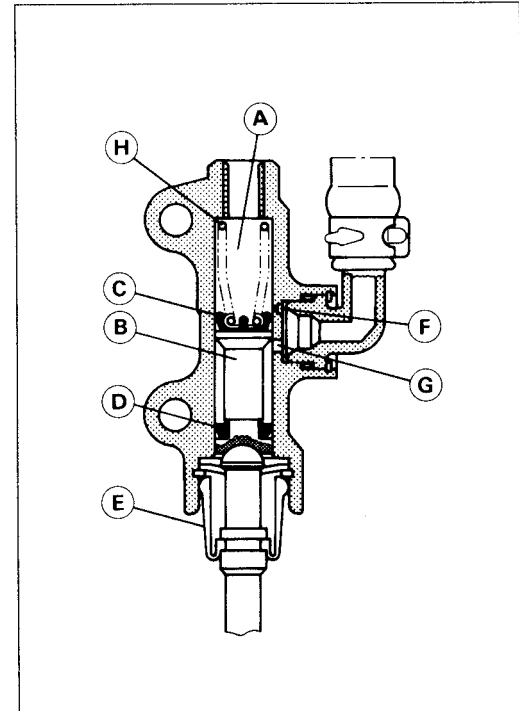

Brake Disc

Wear

★ Replace the disc [A] if it has worn past the service limit.

Front Disc Thickness

Standard: 4.8 – 5.1 mm

Service Limit: 4.5 mm

[B] Measuring Area

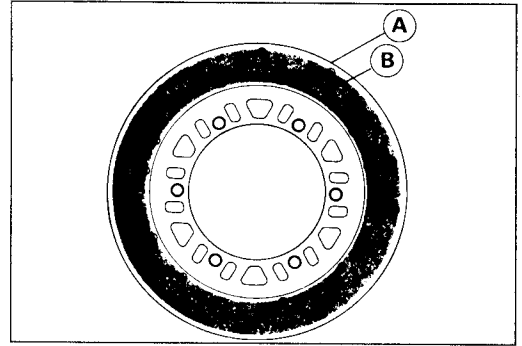

Rear Disc Thickness

Standard: 5.8 – 6.1 mm

Service Limit: 5.0 mm

Warp

★ If runout exceeds the service limit, replace the disc [A].

Disc Runout

Standard: Under 0.2 mm

Service Limit: 0.3 mm

[B] Measuring Area

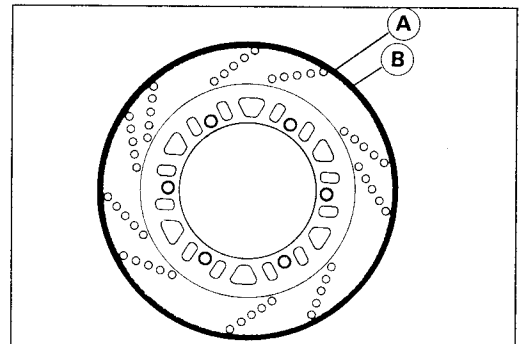

11-14 BRAKES

Brake Fluid

Level Inspection

In accordance with the Periodic Maintenance Chart, inspect the brake fluid level in the front and rear brake fluid reservoirs.

- Check that the brake fluid level in the front brake reservoir [A] is above the lower level line [B].

NOTE

- Hold the reservoir horizontal by turning the handlebar when checking brake fluid level.

- ★ If the fluid level is lower than the lower level line, fill the reservoir to the upper level line [A] in the reservoir [B].

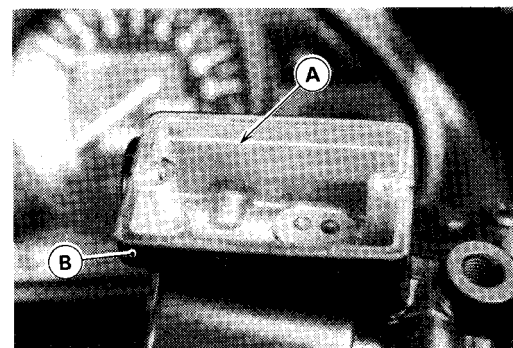
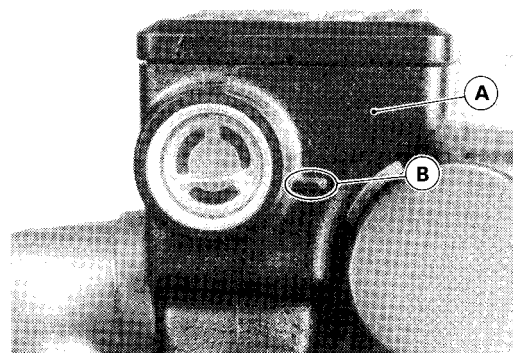

- Remove the seat, and check that the brake fluid level in the rear brake reservoir [A] is between the upper [B] and the lower [C] level lines.

- ★ If the fluid level is lower than the lower level line, fill the reservoir to the upper level line.

⚠WARNING

Change the brake fluid in the brake line completely if the brake fluid must be refilled but the type and brand of the brake fluid that is already in the reservoir are unidentified. After changing the fluid, use only the same type and brand of fluid thereafter.

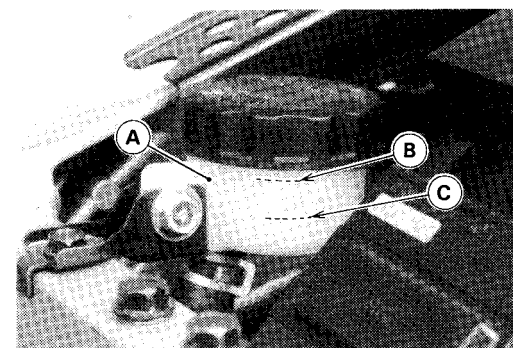

Recommended Disc Brake Fluid

Grade: D.O.T.4

Brand: Castrol Girdling-Universal

Castrol GT (LMA)

Castrol Disc Brake Fluid

Check Shock Premium Heavy Duty

Change

NOTE

- The procedure to change the front brake fluid is as follows.
Changing the rear brake fluid is the same as for the front brake.

- Level the brake fluid reservoir.
- Remove the reservoir cap.
- Remove the rubber cap from the bleed valve [A] on the caliper.
- Attach a clear plastic hose [B] to the bleed valve, and run the other end of the hose into a container.

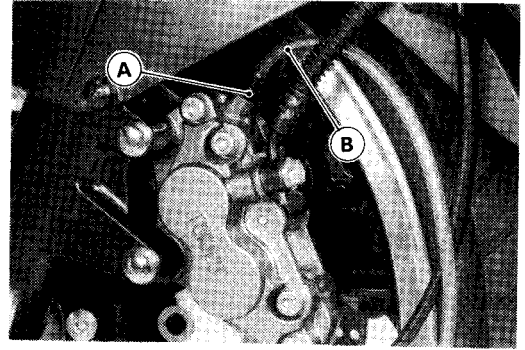

- Change the brake fluid as follows:
- Repeat this operation until fresh brake fluid comes out from the plastic hose or the color of the fluid changes.

1. Open the bleed valve [A].
2. Apply the brake and hold it [B].
3. Close the bleed valve [C].
4. Release the brake [D].

NOTE

- The fluid level must be checked often during the changing operation and replenished with fresh brake fluid. If the fluid in the reservoir runs out any time during the changing operation, the brakes will need to be bled since air will have entered the brake line.
- Front Brake: Repeat the above steps for the other caliper.
- Rear Brake: Repeat the above steps for the other bleed valve.

- Remove the clear plastic hose.
- Install the reservoir cap.
- Tighten the bleed valve, and install the rubber cap.

Torque – Caliper Bleed Valve: 7.8 N-m (0.8 kg-m, 69 in-lb)

- After changing the fluid, check the brake for good braking power, no brake drag, and no fluid leakage.
- ★ If necessary, bleed the air from the lines.

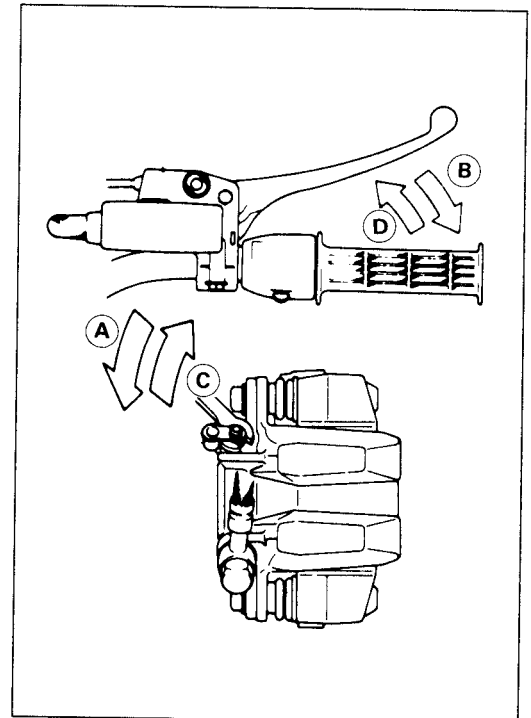

Bleeding the Brake Line

The brake fluid has a very low compression coefficient so that almost all the movement of the brake lever or pedal is transmitted directly to the caliper for braking action. Air, however, is easily compressed. When air enters the brake lines, brake lever or pedal movement will be partially used in compressing the air. This will make the lever or pedal feel spongy, and there will be a loss in braking power.

▲ WARNING

Be sure to bleed the air from the brake line whenever brake lever or pedal action feels soft or spongy after the brake fluid is changed, or whenever a brake line fitting has been loosened for any reason.

NOTE

○ *The procedure to bleed the front brake line is as follows. Bleeding the rear brake line is the same as for the front brake.*

- Remove the reservoir cap, and fill the reservoir with fresh brake fluid to the upper level line in the reservoir.
- With the reservoir cap off, slowly pump the brake lever several times until no air bubbles can be seen rising up through the fluid from the holes at the bottom of the reservoir.
- Bleed the air completely from the master cylinder by this operation.
- Install the reservoir cap.
- Remove the rubber cap from the bleed valve on the caliper.
- Attach a clear plastic hose to the bleed valve, and run the other end of the hose into a container.
- Bleed the brake line and the caliper as follows:
- Repeat this operation until no more air can be seen coming out into the plastic hose.
 1. Pump the brake lever until it becomes hard, and apply the brake and hold it [A].
 2. Quickly open and close [B] the bleed valve while holding the brake applied.
 3. Release the brake [C].

NOTE

- *The fluid level must be checked often during the bleeding operation and replenished with fresh brake fluid as necessary. If the fluid in the reservoir runs completely out any time during bleeding, the bleeding operation must be done over again from the beginning since air will have entered the line.*
- *Tap the brake hose lightly from the caliper to the reservoir for more complete bleeding.*
- *Front Brake: Repeat the above steps for the other caliper.*
- *Rear Brake: Repeat the above steps for the other bleed valve.*

- Remove the clear plastic hose.
- Tighten the bleed valve, and install the rubber cap.

Torque – Caliper Bleed Valve: 7.8 N-m (0.8 kg-m, 69 in-lb)

- Check the fluid level.
- After bleeding is done, check the brake for good braking power, no brake drag, and no fluid leakage.

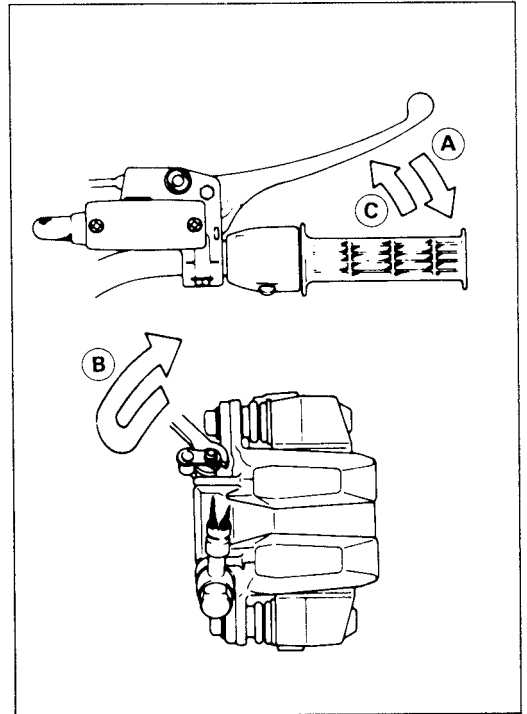

Suspension

Table of Contents

Exploded View	12-2
Specifications	12-4
Front Fork	12-5
Rebound Damping Force Adjustment	12-5
Spring Preload Adjustment	12-5
Fork Oil Change	12-6
Removal (each fork leg)	12-7
Installation	12-7
Disassembly	12-7
Assembly	12-8
Inner Tube Inspection	12-9
Dust Seal Inspection	12-9
Spring Tension	12-9
Rear Suspension	12-10
Rear Shock Absorber:	12-10
Rebound Damping Force Adjustment	12-10
Spring Preload Adjustment	12-10
Removal	12-11
Installation	12-11
Scrapping	12-11
Swing Arm	12-12
Removal	12-12
Installation	12-13
Tie-Rod, Rocker Arm:	12-14
Tie-Rod Removal	12-14
Tie-Rod Installation	12-14
Rocker Arm Removal	12-14
Rocker Arm Installation	12-14
Needle Bearing Inspection	12-14
Tie-Rod, Rocker Arm Sleeve Inspection	12-15
Tie-Rod, Rocker Arm Needle Bearing Lubrication	12-15

12-2 SUSPENSION

Exploded View

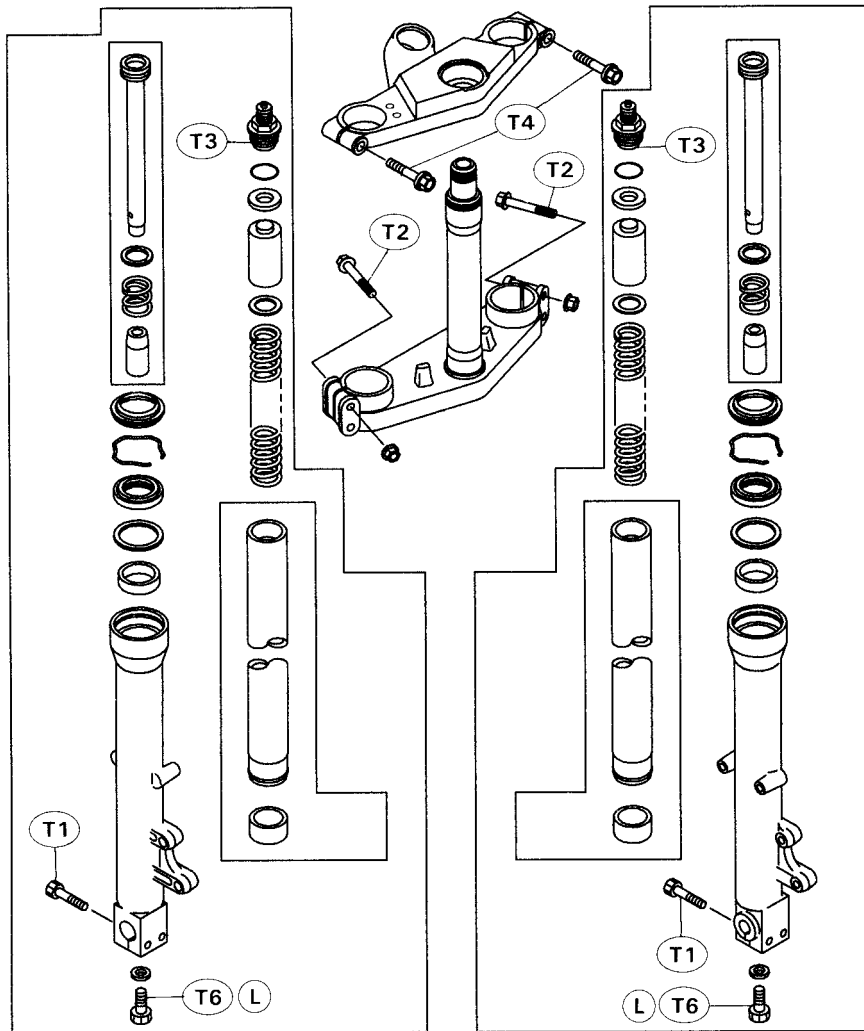

- G:** Apply grease
- L:** Apply non-permanent locking agent.
- M:** Apply molybdenum disulfide grease.
- T1:** 20 N-m (2.0 kg-m, 14.5 ft-lb)
- T2:** 21 N-m (2.1 kg-m, 15.0 ft-lb)
- T3:** 23 N-m (2.3 kg-m, 16.5 ft-lb)
- T4:** 28 N-m (2.9 kg-m, 21 ft-lb)
- T5:** 59 N-m (6.0 kg-m, 43 ft-lb)
- T6:** 61 N-m (6.2 kg-m, 45 ft-lb)
- T7:** 88 N-m (9.0 kg-m, 65 ft-lb)

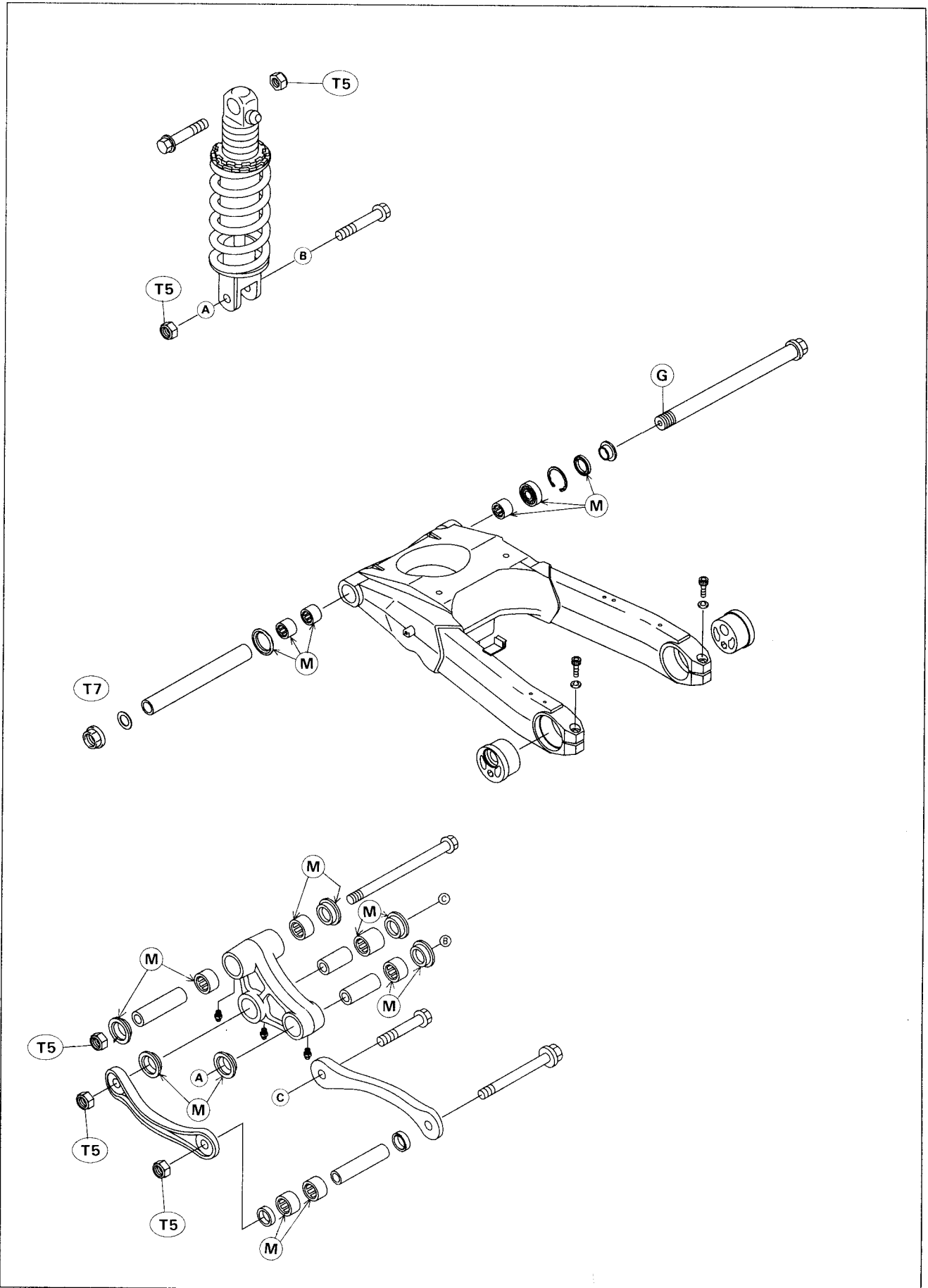

12-4 SUSPENSION

Specifications

Item	Standard	Service Limit
Front Fork:		
Damper adjuster position	2nd click (clockwise)	1 ~ 4
Spring preload adjuster position	6th mark from top	1 ~ 8
Fork oil: Viscosity	SAE 10W-20	---
Amount per unit	465 ± 4 mL * 467 ± 4 mL	---
	410 mL: When changing oil	---
Fork oil level	133 ± 2 mm * 131 ± 2 mm (Fully compressed, without spring)	---
Fork spring free length	295 mm * 296 mm	289 mm
Rear Suspension:		
Rear shock absorber damper adjuster position	# 2	1 ~ 4
Rear shock absorber spring preload adjustment	19 mm (compressed from spring free length)	19 ~ 31 mm

(*) : ZX1100-D3

Special Tool – Fork Cylinder Holder Handle: 57001-183
Oil Seal & Bearing Remover: 57001-1058
Steering Stem Nut Wrench: 57001-1100
Bearing Driver Set: 57001-1129
Fork Outer Tube Weight: 57001-1218
Front Fork Oil Seal Driver: 57001-1219
Fork Oil Level Gauge: 57001-1290
Hexagon Wrench, Hex 29: 57001-1335

Front Fork

Rebound Damping Force Adjustment

● To adjust the rebound damping force, turn the adjuster [A] clockwise until you feel a click [B]. Each adjuster has 4 adjustment clicks. Be sure to turn both adjusters by the same number of clicks.

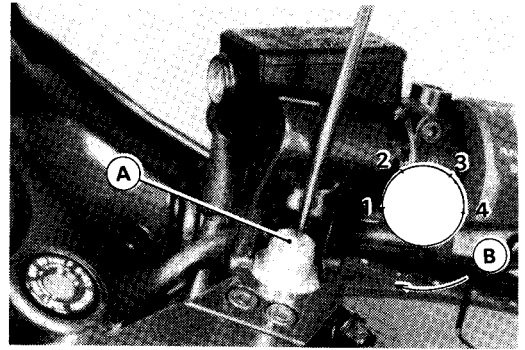

⚠ WARNING

If both adjusters are not adjusted equally, handling may be impaired and a hazardous condition may result.

○ The damping force can be left soft for average riding. But it should be adjusted harder for high speed riding or riding with a passenger. If the damping feels too soft or too stiff, adjust it in accordance with the following table.

Rebound Damping Force Adjustment

Adjuster Position	Damping Force	Setting	Load	Road	Speed
1	Weak	Soft	Light	Good	Low
↑	↑	↑	↑	↑	↑
↓	↓	↓	↓	↓	↓
4	Strong	Hard	Heavy	Bad	High

○ The standard adjuster setting for an average-build rider of 68 kg (150 lb) with no passenger and no accessories is the **2nd click** position.

Spring Preload Adjustment

● Turn the adjuster [A] in to increase spring preload and out to decrease spring preload. Each adjuster has 8 adjustment marks [B]. Be sure to position both adjusters to the same mark.

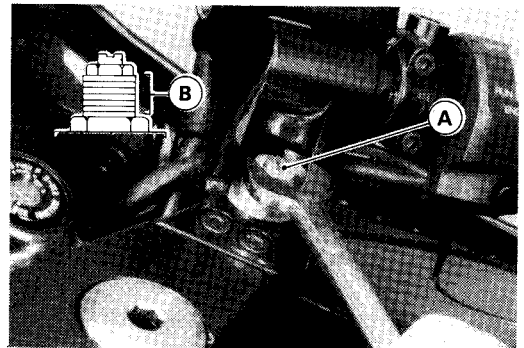

⚠ WARNING

If both adjusters are not adjusted equally, handling may be impaired and a hazardous condition may result.

○ The spring preload can be left soft for average riding. But it should be adjusted harder for high speed riding or riding with a passenger. If the spring action feels too soft or too stiff, adjust it in accordance with the following table.

Spring Action

Adjuster Position	Dumping Force	Setting	Load	Road	Speed
8	Weak	Soft	Light	Good	Low
↑	↑	↑	↑	↑	↑
↓	↓	↓	↓	↓	↓
1	Strong	Hard	Heavy	Bad	High

○ The standard adjuster setting for an average-build rider of 68 kg (150 lb) with no passenger and no accessories is the **6th mark** position from the top.

12-6 SUSPENSION

Fork Oil Change

- Remove the following.
 - Seat
 - Fuel Tank
 - Upper Fairing
 - Lower Fairing
 - Fork Leg
 - Fork Top Bolt
 - Spring Seat
 - Main Spring
- Pour out the fork oil into a suitable container. Pump as necessary to empty out all the oil.
- Pour in the specified type and amount of oil.

Front Fork Oil

Viscosity: SAE 10W-20

Amount per side:

When changing oil: 410 mL

After disassembly and completely dry:

ZX1100-D1, D2 465 ± 4 mL

ZX1100-D3 467 ± 4 mL

- ★ If necessary, measure the oil level as follows.
 - Hold the outer tube vertically in a vise.
 - Pump the inner tube several times to expel air bubbles.
 - Wait until the oil level settle.
 - With the fork fully compressed, insert a tape measure or rod into the inner tube, and measure the distance from the top of the inner tube to the oil.

NOTE

- Fork oil level may also be measured using the fork oil level gauge (special tool).

Special Tool – Fork Oil Level Gauge: 57001-1290 [A]

- Set the gauge stopper [B] so that its lower side shows the oil level distance specified.

Oil Level (fully compressed, without spring)

Standard: ZX1100-D1, D2 133 ± 2 mm

ZX1100-D3 131 ± 2 mm

(from the top of the inner tube.)

- With the fork fully compressed, insert the gauge tube into the inner tube and position the stopper across the inner tube top end.

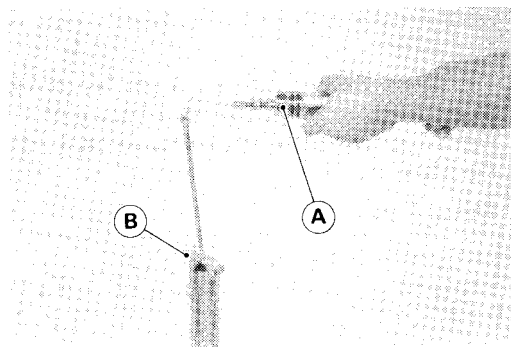

NOTE

- Adjust the oil level with the fork fully compressed and without the fork spring.
- Position the stopper so that the gauge tube is the center of inner tube diameter, or the specified oil level cannot be obtained.
- Pull the handle slowly to pump out the excess oil until the oil no longer comes out.
- ★ If no oil is pumped out, there is insufficient oil in the inner tube. Pour in enough oil, then pump out the excess oil as shown above.
- Change the oil of the other fork leg in the same manner.
- Install the fork (see Installation Notes).

Removal (each fork leg)

- Loosen the fork top plug beforehand if the fork leg is to be disassembled.
- Remove the following.
 - Upper Fairing
 - Lower Fairing
 - Front Fender
 - Front Wheel
 - Fork Clamp Bolts and Nuts (Upper [A] and lower [B], loosen)
- With a twisting motion, work the fork leg down and out.

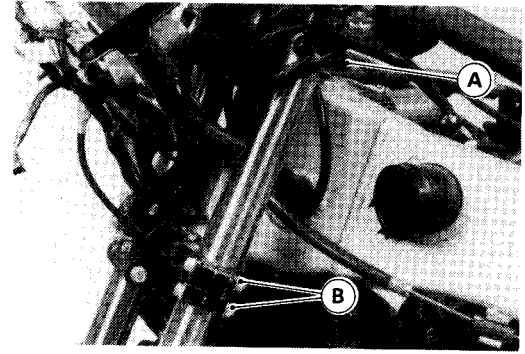

Installation

- Pull back the fork leg.
- Tighten the front fork upper clamp bolts.
 - Torque – Front Fork Upper Clamp Bolts : 28 N-m(2.9 kg-m, 21 ft-lb)**
- Tighten the steering stem head nut.
 - Torque – Steering Stem Head Nut : 39 N-m(4.0 kg-m, 29 ft-lb)**
- Tighten the front fork lower clamp bolts.
 - Torque – Front Fork Lower Clamp Bolts : 21 N-m(2.1 kg-m, 15 ft-lb)**
- Adjust the following.
 - Rebound Damping Force
 - Spring Preload

Disassembly

- Drain the fork oil (see Fork Oil Change).

- Unscrew the Allen bolt [A], and take the gasket out of the bottom of the outer tube.

**Special Tool – Fork Cylinder Holder Handle: 57001-183 [B]
Hexagon Wrench, Hex 29: 57001-1335 [C]**

- Hold the fork outer tube in a vice.
- Stopping the cylinder from turning by using the special tools, unscrew the Allen bolt.

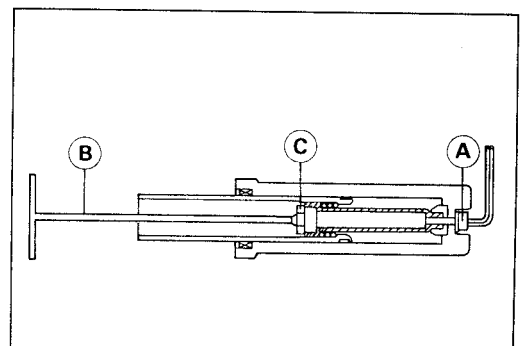

12-8 SUSPENSION

- Use the fork outer tube weight [A] to separate the inner tube [B] from the outer tube [C].
- Holding the inner tube by hand in a vertical position, pull down [D] the outer tube several times to pull out the inner tube.

Special Tool – Fork Outer Tube Weight: 57001-1218

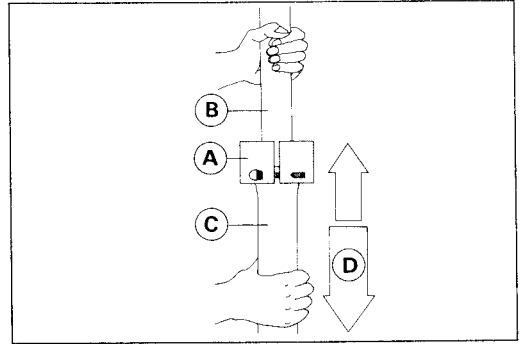

- The oil seal [A], washer [B], and gauge bushes [C] come off with the inner tube.

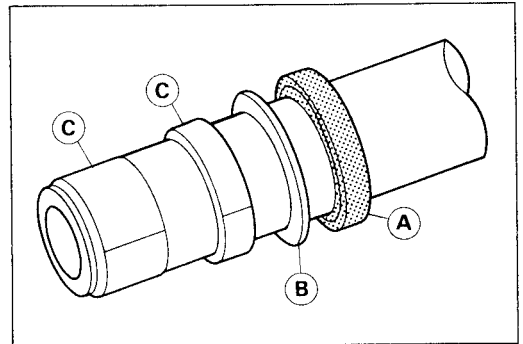

Assembly

- Assembly is the reverse of disassembly. Note the following.
- Check the top plug O-ring and replace it with a new one if necessary.
- Replace the following parts removed with a new one,
 - Guide Bushes
 - Oil Seal
 - Bottom Allen Bolt Gasket
- Install the cylinder base [A] so that the small diameter end [B] of it comes to the cylinder.
 - [C] Large Diameter End

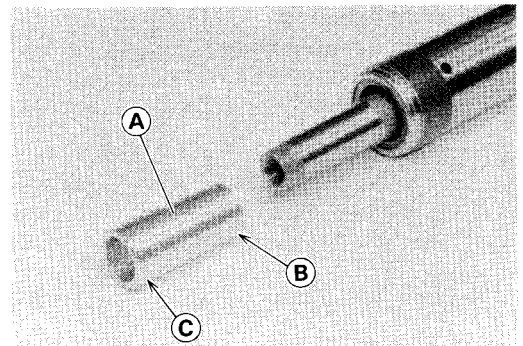

- Apply a non-permanent locking agent to the following.
 - Bottom Allen Bolt Threads
- Tighten the bottom Allen bolt and fork top bolt.

Torque – Bottom Allen Bolt : 61 N-m(6.2 kg-m, 45 ft-lb)

Fork Top Bolt (after fork leg installation): 23 N-m(2.3 kg-m, 16.5 ft-lb)

- Fit the new outer guide bush [A] into the outer tube.

NOTE

- Hold the used guide bush [B] against the new one, and tap the used guide bush.

Special Tool – Fork Oil Seal Driver: 57001-1219 [C]

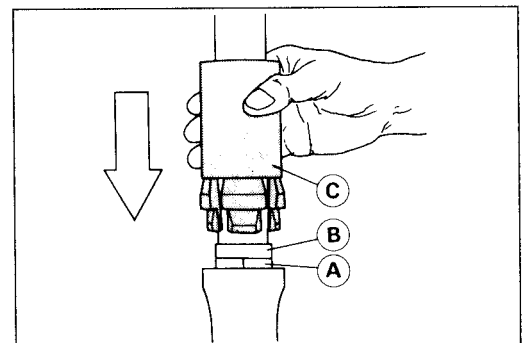

- Pour in the type and amount of fork oil specified.
- Install the top bolt [A] so that the rod [D] of it inserts into the center hole [E] of the damping valve. The spring seat [C] must be fitted onto the stepped portion [B] of the top bolt.

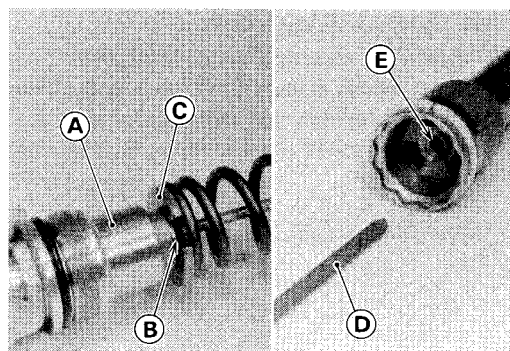

Inner Tube Inspection

- Visually inspect the inner tube, and repair any damage.
- Nicks or rust damage can sometimes be repaired by using a wet-stone to remove sharp edges or raised areas which cause seal damage.
- ★ If the damage is not repairable, replace the inner tube. Since damage to the inner tube damages the oil seal, replace the oil seal whenever the inner tube is repaired or replaced.
- Temporarily assemble the inner and outer tubes, and pump them back and forth manually to check for smooth operation.

CAUTION

If the inner tube is badly bent or creased, replace it. Excessive bending, followed by subsequent straightening, can weaken the inner tube.

Dust Seal Inspection

- Inspect the dust seal [A] for any signs of deterioration or damage.
- ★ Replace it if necessary.

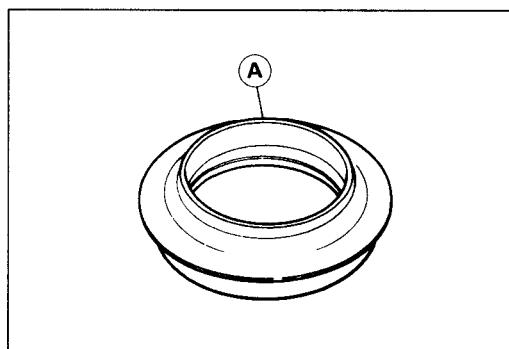

Spring Tension

- Since a spring becomes shorter as it weakens, check its free length [A] to determine its condition.
- ★ If the spring of either fork leg is shorter than the service limit, it must be replaced. If the length of a replacement spring and that of the remaining spring vary greatly, the remaining spring should also be replaced in order to keep the fork legs balanced for motorcycle stability.

Spring Free Length

Standard: 295 mm, ZX1100-D3 : 296 mm
 Service Limit: 289 mm

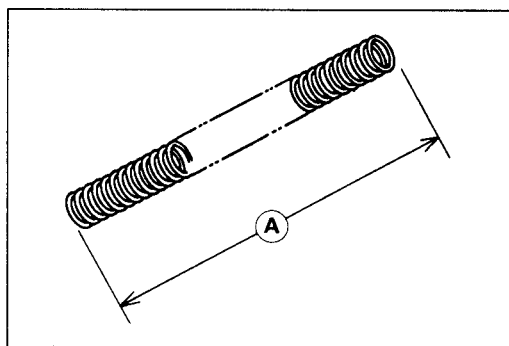

12-10 SUSPENSION

Rear Suspension

Rear Shock Absorber:

Rebound Damping Force Adjustment

- Pull the plastic cover off the lower end of the shock absorber.
- To adjust the rebound damping force, turn the adjuster [A] rightward [B] to the desired number until you feel a click.

NOTE

- The damping adjuster will turn in one direction only as indicated on it.
- The damping force can be left soft for average riding. But it should be adjusted harder for high speed riding or riding with a passenger. If the damping feels too soft or too stiff, adjust it in accordance with the table.
- The standard adjuster setting for an average-build rider of 68 kg (150 lb) with no passenger and no accessories is (2).

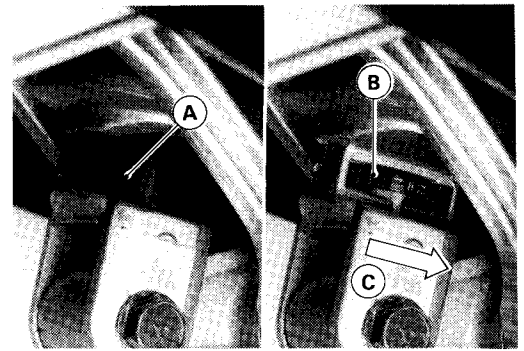

Rebound Damping Force Adjustment

Adjuster Position	Damping Force	Setting	Load	Road	Speed
1	Weak	Soft	Light	Good	Low
↑	↓	↓	↓	↓	↓
4	Strong	Hard	Heavy	Bad	High

Spring Preload Adjustment

- Remove the rear shock absorber.
- Loosen the locknut and turn out the adjusting nut to free the spring.

Special Tool – Steering Stem Nut Wrench: 57001-1100

- Measure the spring [D] free length [A].
- Turn in the adjusting nut [C] to the desired position and tighten the locknut [B].

Spring Preload Setting

Standard: Spring free length minus 19.5 mm
Usable Range: Spring free length minus 19 to 31 mm (weaker to stronger)

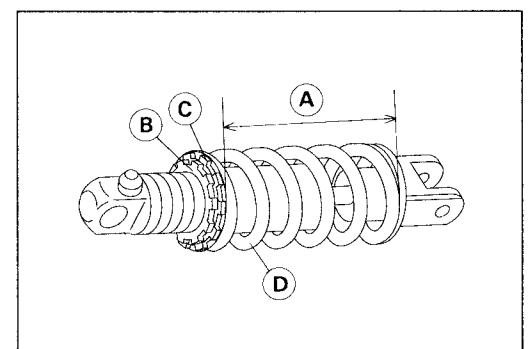

- The spring preload can be left soft for average riding. But it should be adjusted harder for high speed riding or riding with a passenger. If the spring action feels too soft or too stiff, adjust it in accordance with the table.
- The standard adjusting nut setting for an average-build rider of 68 kg (150 lb) with no passenger and no accessories is 19.5 mm of spring preload from the free length.

Spring Action

Spring Force	Setting	Load	Road	Speed
Weak	Soft	Light	Good	Low
↑	↓	↓	↓	↓
Strong	Hard	Heavy	Bad	High

Removal

- Remove the following.
 - Seat
 - Fuel Tank
 - Side Covers
 - Rear Wheel (see Wheel/Tires chapter)
 - Rear Fenders (see Frame chapter)

- Remove the following.
 - Rear Shock Absorber Mounting Bolts[A].

CAUTION

When pulling out the mounting bolts, lift the rear wheel slightly. Forcing or tapping on a bolt could damage the bolt, sleeve, and bearing.

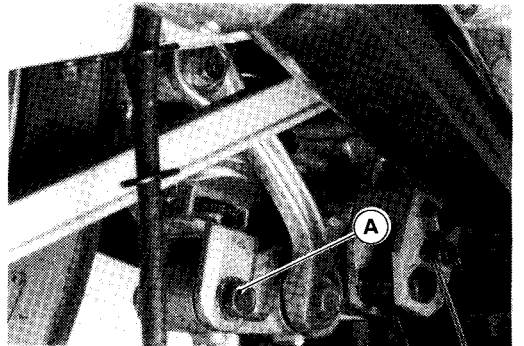
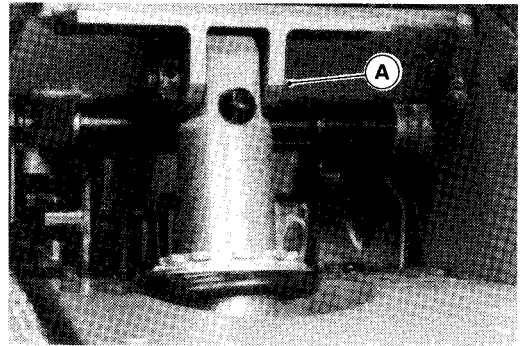
*Installation*

- Installation is the reverse of removal. Note the following.
- Adjust the following.
 - Rebound Damping Force
 - Spring Preload
- Install the rear shock absorber on the frame so that the rebound damping force adjuster cover faces toward the right side.
- Tighten the rear shock absorber mounting bolts.

Torque – Rear Shock Absorber Mounting Bolts : 59 N-m(6.0 kg-m, 43 ft-lb)

*Scrapping***⚠WARNING**

Since the rear shock absorber contains nitrogen gas, do not incinerate the rear shock absorber without first releasing the gas or it may explode.

12-12 SUSPENSION

Swing Arm

Removal

CAUTION

Holding the brake lever keeps the motorcycle from falling down during the following procedure.

- Remove the chain case[A].

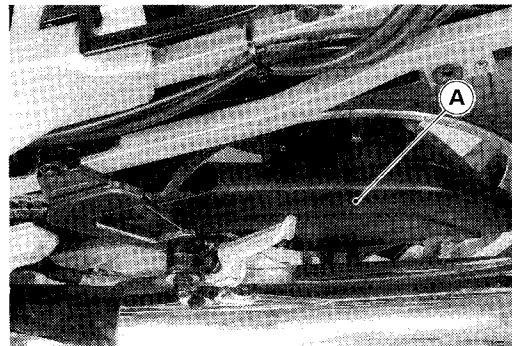

- Remove the torque link rear bolt[A].
- Remove the rear wheel (see Wheel/Tire chapter).

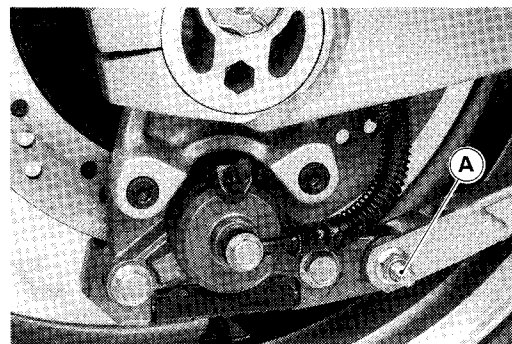

- Remove the Allen bolts[A] and off the rear brake pedal bracket[B] with the master cylinder fitted from the frame.

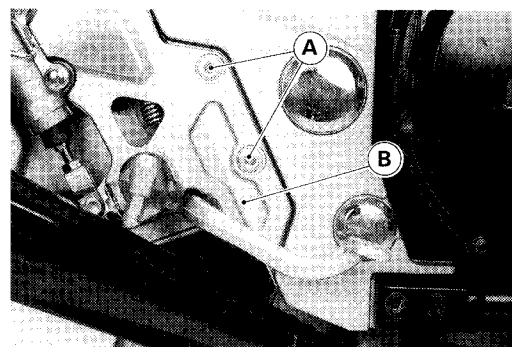

- Remove the circlip [A] and unscrew the torque link front bolt[B] to take off the torque link[C].

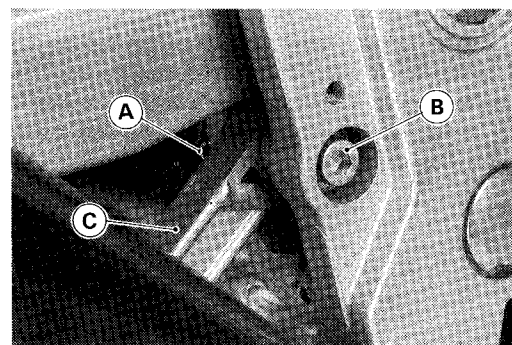

- Remove the rear brake hose[A] from the clamps[B].

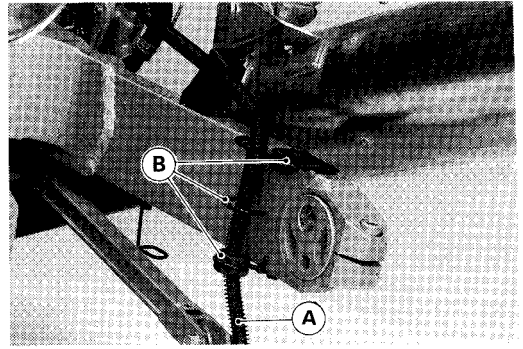

- Remove the lower tie-rod bolt[A] and lower shock absorber bolt[B].

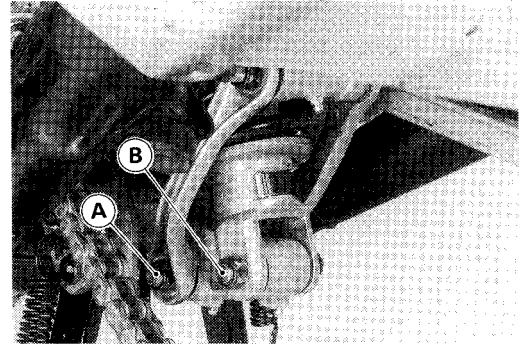

- Remove the swing arm pivot shaft[A] whole supporting the swing arm.
- Remove the swing arm toward the rear with the chain inward of the swing arm.

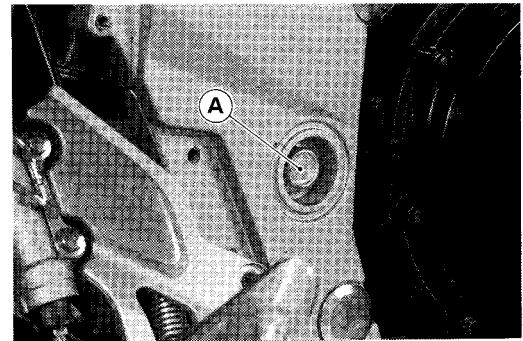

Installation

- Installation is the reverse of removal. Note the following.
- If the swing arm is hard to be installed in place, removal of the rear fender and rear shock are recommended.
- Apply molybdenum disulfide grease to the inside of the needle bearings.
- Be sure that the washer[A] is fitted at the left side of the swing arm pivot.

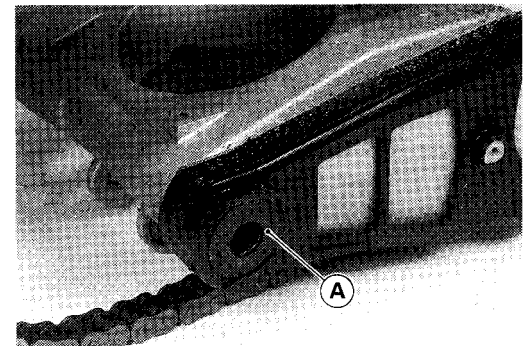

- Tighten the following nuts.

Torque – Swing Arm Pivot Nut :	88 N-m(9.0 kg-m, 65 ft-lb)
Shock Absorber Nut :	59 N-m(6.0 kg-m, 43 ft-lb)
Tie Rod Nut :	59 N-m(6.0 kg-m, 43 ft-lb)
Torque Link Nut :	25 N-m(2.5 kg-m, 18 ft-lb)

- Adjust the drive chain after installation (see Final Drive chapter).

12-14 SUSPENSION

Tie-Rod, Rocker Arm:

Tie-Rod Removal

- Remove the torque link from the caliper holder.
- Remove the tie-rod lower bolt. [A]
- Remove the tie-rod upper bolts [B] and take the tie-rod [C] off.
- Remove the other tie-rod.

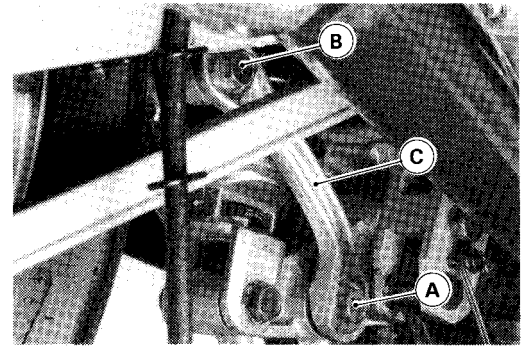

Tie-Rod Installation

- Apply molybdenum disulfide grease to the inside of the needle bearings.
- Tighten the tie-rod upper and lower bolts.

Torque – Tie-Rod Bolts : 59 N-m(6.0 kg-m, 43 ft-lb)

Rocker Arm Removal

- Remove the following.
 - Lower Fairing
 - Radiator
 - Muffler
- Remove the shock absorber bolt [A], tie-rod bolt [B], and rocker arm shaft [C].

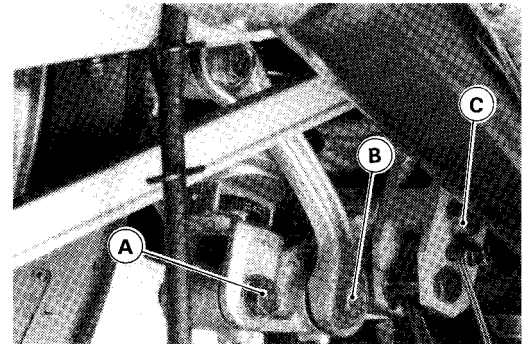

Rocker Arm Installation

- Installation is the reverse of removal. Note the following.
- Apply molybdenum disulfide grease to the inside of the needle bearings.

Torque – Rocker Arm Nut 59 N-m(6.0 kg-m, 43 ft-lb)
Shock Absorber Nut 59 N-m(6.0 kg-m, 43 ft-lb)
Tie-Rod Nut 59 N-m(6.0 kg-m, 43 ft-lb)

Needle Bearing Inspection

- ★ If there is any doubt as to the condition of either needle bearing, replace the bearing and sleeve as a set.

Tie-Rod, Rocker Arm Sleeve Inspection

- ★ If there is visible damage, replace the sleeve and needle bearing as a set.

Tie-Rod, Rocker Arm Needle Bearing Lubrication

There is a grease nipple on the tie-rod and rocker arm for lubrication.

- Force the molybdenum disulfide grease into the nipple until it comes out at both sides of the tie-rod or rocker arm, and wipe off any excess.

Steering

Table of Contents

Exploded View	13-2
Steering	13-4
Adjustment	13-4
Steering Stem	13-5
Removal	13-5
Stem, Stem Bearing Installation	13-5
Stem Bearing Lubrication	13-7

13-2 STEERING

Exploded View

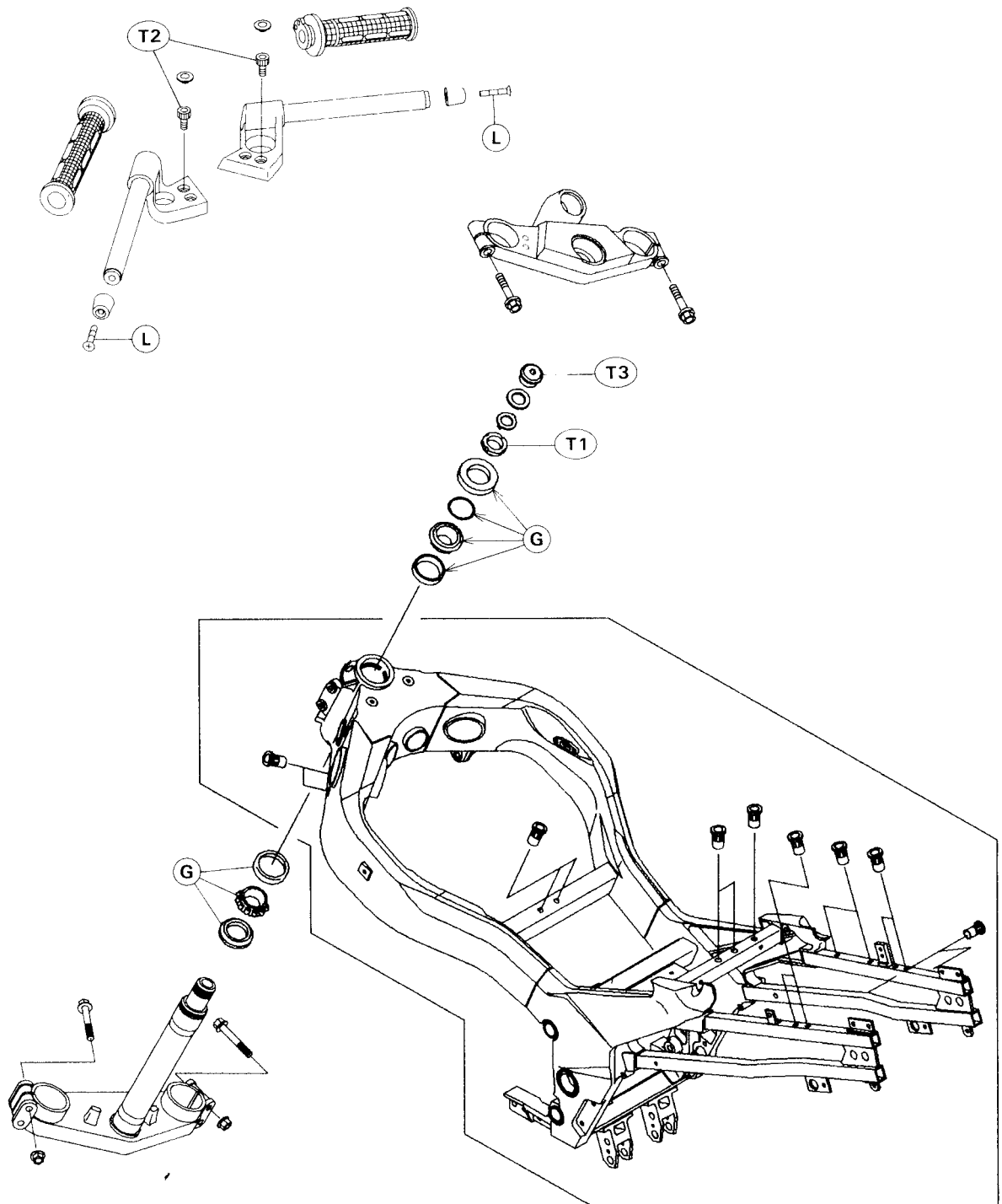

G : Apply grease
L : Apply non-permanent locking agent

T1 : 4.9 N-m (0.50 kg-m, 43 in-lb)

T2 : 20 N-m (2.0 kg-m, 14.5 ft-lb)

T3 : 39 N-m (4.0 kg-m, 29 ft-lb)

Special Tool – Bearing Puller Adapter: 57001-136
Steering Stem Bearing Driver: 57001-137
Bearing Puller: 57001-158
Bearing Puller Adapter: 57001-317
Steering Stem Bearing Driver Adapter: 57001-1074
Head Pipe Outer Race Press Shaft: 57001-1075
Head Pipe Outer Race Driver: 57001-1076
Head Pipe Outer Race Driver: 57001-1077
Steering Stem Nut Wrench: 57001-1100
Head Pipe Outer Race Remover: 57001-1107
Jack: 57001-1238

13-4 STEERING

Steering

Adjustment

- Check the steering.
- Lift the front wheel off the ground using the jack stand.

Special Tool – Jack: 57001-1238

- With the front wheel pointing straight ahead, alternately tap each end of the handlebar. The front wheel should swing fully left and right from the force of gravity until the fork hits the stop.
- ★ If the wheel binds or catches before the stop, the steering is too tight.
- Feel for steering looseness by pushing and pulling the forks.
- ★ If you feel looseness, the steering is too loose.

NOTE

- *The cables and wiring will have some effect on the motion of the fork which must be taken into account.
Be sure the wires and cables are properly routed.*
- *The bearings must be in good condition and properly lubricated in order for any test to be valid.*

★ Adjust the steering if necessary.

● Remove the following parts.

Seat

Fuel Tank

Inner Rear Fairing

Fork Lower Clamp Bolts (both sides)

Stem Head Cover

Stem Head Nut (Loosen) [A]

● Adjust the steering. [A]

Special Tool – Steering Stem Nut Wrench: 57001-1100 [B]

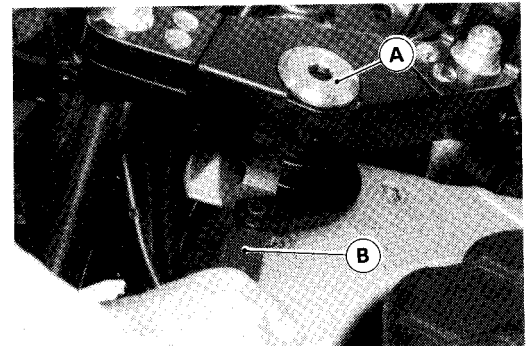

- ★ If the steering is too tight, loosen the stem locknut a fraction of a turn.
- ★ If the steering is too loose, tighten the locknut a fraction of a turn.

NOTE

- *Turn the locknut 1/8 turn at a time maximum.*

● Tighten the steering stem head nut.

Torque – Steering Stem Head Nut: 39 N-m(4.0 kg-m, 29 ft-lb)

● Check the steering again.

★ If the steering is still too tight or too loose, repeat the adjustment.

Steering Stem

Removal

- Remove the following parts.
 - Seat
 - Fuel Tank
 - Upper Fairing
 - Inner Fairings
 - Front Wheel
 - Front Fork Legs
- Remove the brake hose joint [A] from the stem base, and remove the front brake assembly as a set.
 - [B] Brake Hose Joint Mounting Bolts
- Remove stem head nut and take off the steering stem head.
- Push up on the stem base, and remove the lock washer [A], the steering stem locknut [B], then remove the steering stem base.

Special Tool – Steering Stem Nut Wrench: 57001-1100

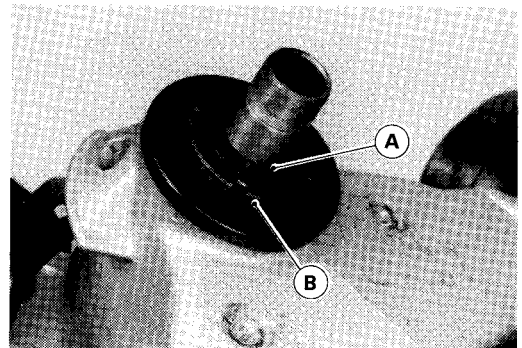
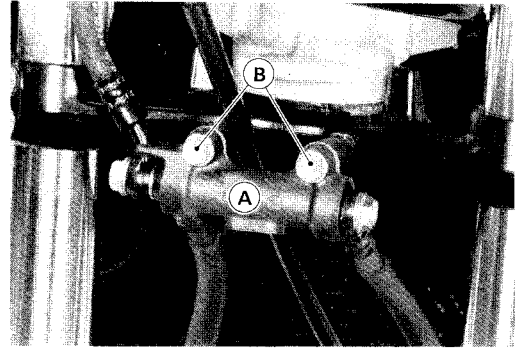

- Drive out the bearing outer races from the head pipe.

Special Tool – Head Pipe Outer Race Remover: 57001-1107 [A]

NOTE

- If either steering stem bearing is damaged, it is recommended that both the upper and lower bearings (including outer races) be replaced with new ones.

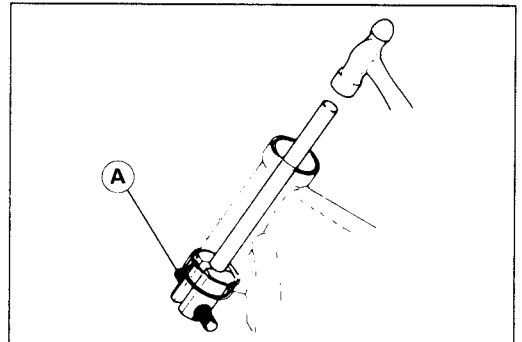

- Remove the lower stem bearing inner race [A] from the stem.

Special Tool – Bearing Puller: 57001-158 [B]

Bearing Puller Adapter: 57001-136 [C]

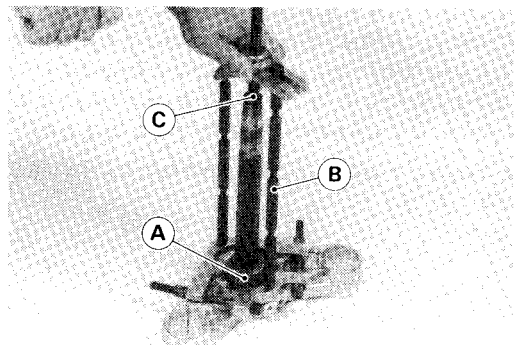

Stem, Stem Bearing Installation

- Replace the bearing outer races with new ones.
- Apply grease to the outer races, and drive them into the head pipe at the same time.

Special Tool – Head Pipe Outer Race Press Shaft: 57001-1075 [A]

Head Pipe Outer Race Driver: 57001-1076 [B]

Head Pipe Outer Race Driver: 57001-1077 [C]

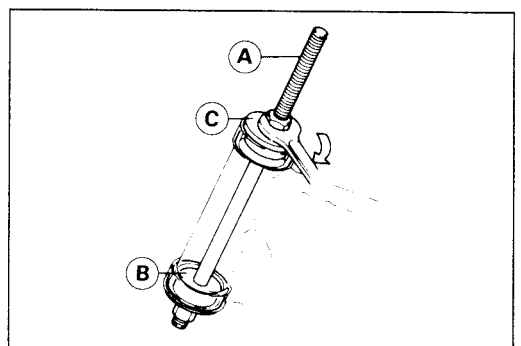

13-6 STEERING

- Replace the stem bearing inner races with new ones.
- Apply grease to the lower inner races, and drive it onto the stem.

**Special Tool – Steering Stem Bearing Driver: 57001-137 [A]
Steering Stem Bearing Driver Adapter: 57001-1074 [B]**

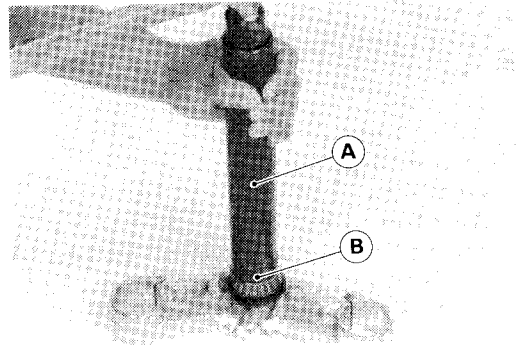

- Apply grease to the upper inner race, and install it in the head pipe.
- Install the stem through the head pipe and the upper bearing, and install the O-ring [A] on the stem shaft while pushing up on the stem base.
- Install the stem cap [B], and hand tighten the locknut [C].

NOTE

- Install the steering stem locknut so that the stepped side [D] faces down.

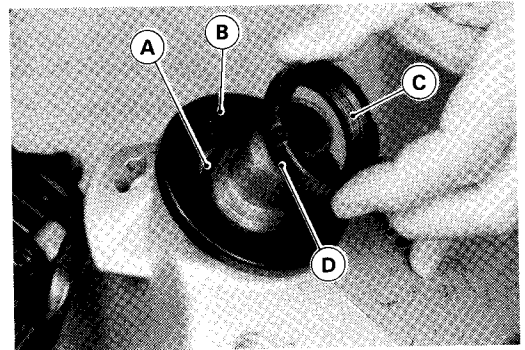

- Install the stem head and the meter assembly.
- Install the washer, and tighten the stem head nut lightly.
- Settle the bearings in place as follows:
- Tighten the stem locknut to 39 N-m (4.0 kg-m, 29 ft-lb) of torque. (To tighten the steering stem locknut to the specified torque, hook the wrench on the stem locknut, and pull the wrench at the hole by 22.2 kg force in the direction shown.)

Special Tool – Steering Stem Nut Wrench: 57001-1100 [A]

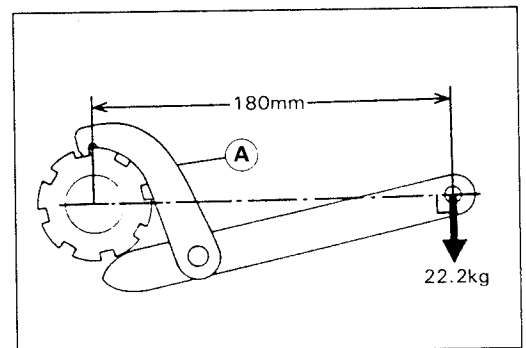

- Check that there is no play and the steering stem turns smoothly without rattles. If not, the steering stem bearings may be damaged.
- Again back out the stem locknut a fraction of a turn until it turns lightly.
- Turn the stem locknut lightly clockwise until it just becomes hard to turn. Do not overtighten, or the steering will be too tight.

Torque – Steering Stem Locknut: 4.9 N-m (0.5 kg-m, 43 in-lb)

- Install the front fork (see Suspension chapter).

NOTE

- With the top end of the fork inner tube flush with upper surface of the stem head, tighten the fork upper clamp bolt first, next the stem head nut, last the fork lower clamp bolts.

**Torque – Steering Stem Head Nut : 39 N-m(4.0 kg-m, 29 ft-lb)
Front Fork Clamp Bolts : 20 N-m (2.0 kg-m, 14.5 ft-lb)
Front Fork Clamp Bolts (Upper) : 28 N-m (2.9 kg-m, 21 ft-lb)
(Lower) : 21 N-m (2.1 kg-m, 15 ft-lb)**

- Install the parts removed (see appropriate chapter).

⚠ WARNING

Do not impede the handlebar turning by routing the cables, harnesses and hoses improperly (see General Information chapters).

Stem Bearing Lubrication

In accordance with the Periodic Maintenance Chart, lubricate the steering stem bearings.

- Remove the steering stem.
- Using a high flash-point solvent, wash the upper and lower tapered roller bearing in the cages, and wipe the upper and lower outer races, which are press-fitted into the frame head pipe, clean of grease and dirt.
- Visually check the outer races and the rollers.
- ★ Replace the bearing assemblies if they show wear or damage.
- Pack the upper and lower tapered roller bearings [A] in the cages with grease, and apply a light coat of grease to the upper and lower outer races.
- Install the steering stem, and adjust the steering.

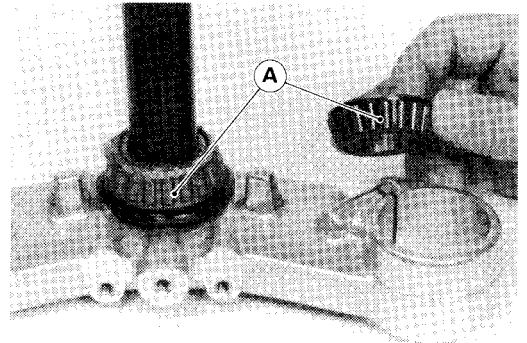

Frame

Table of Contents

Exploded View	14-2
Fairing	14-5
Lower Fairing Removal	14-5
Inner and Upper Fairings	14-5
Upper Fairing Removal	14-5
Side Cover and Tail Cover Removal	14-6
Rear Fender Removal	14-7

14-2 FRAME

Exploded View

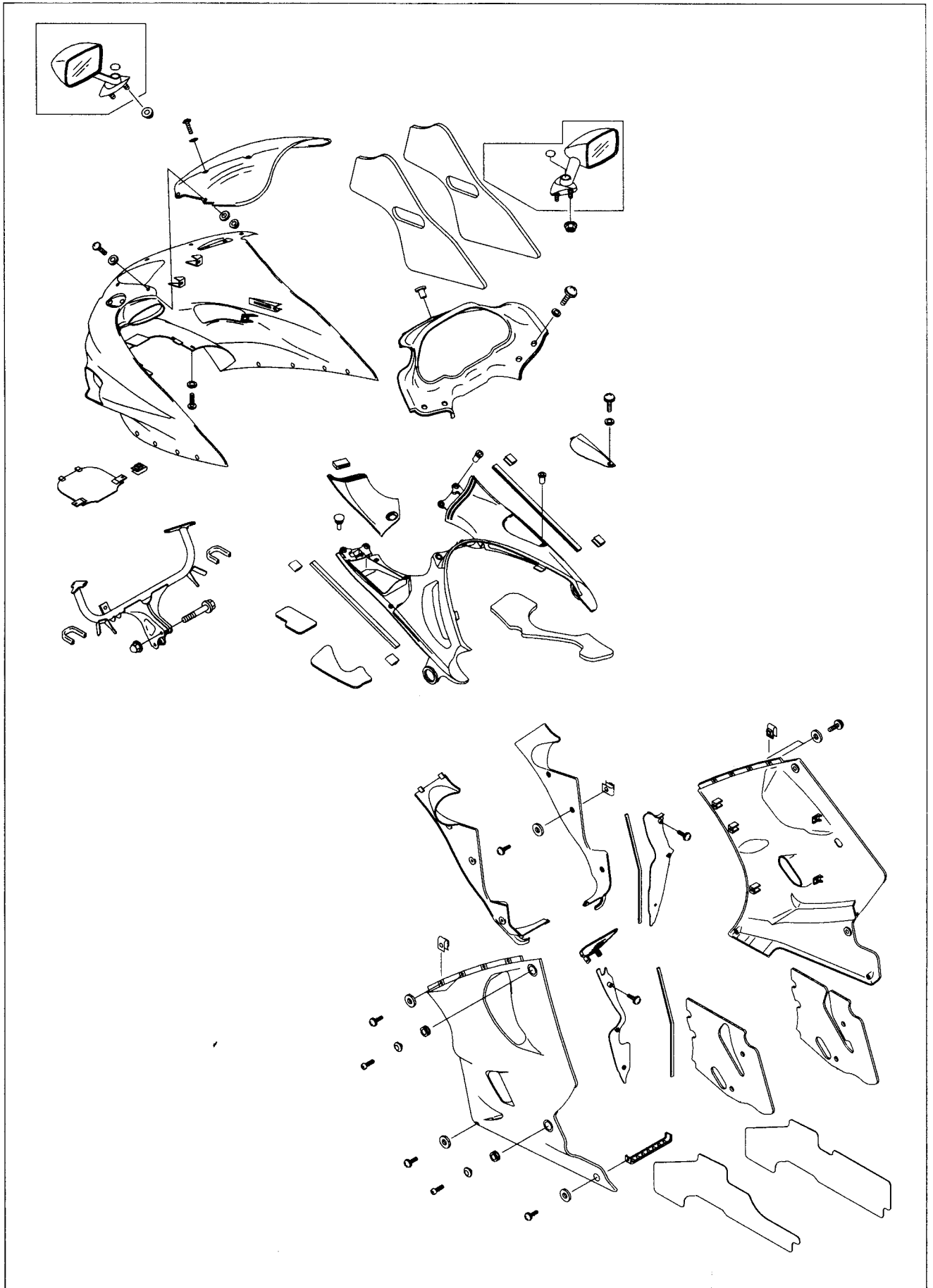

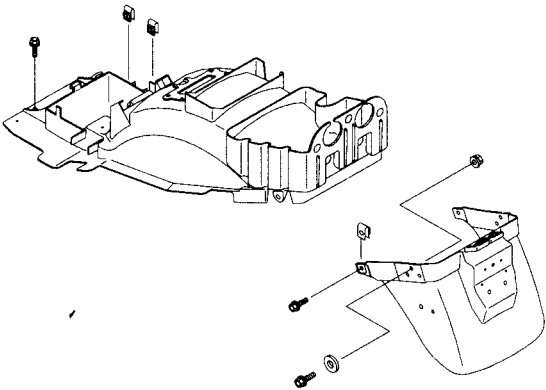
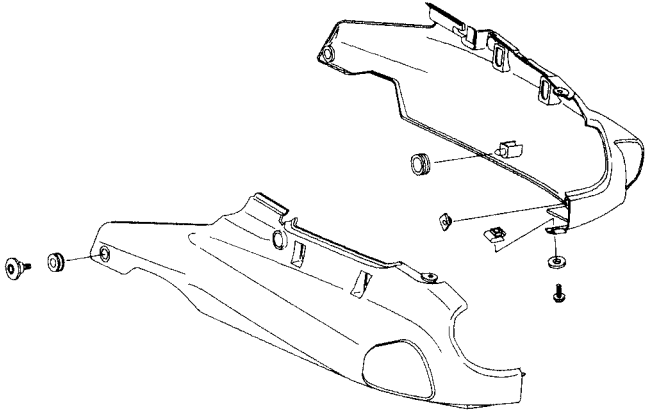
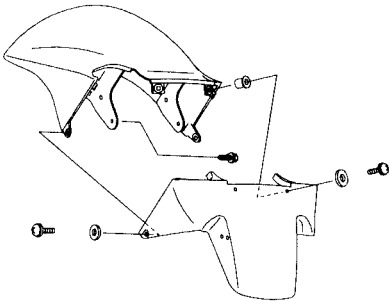

14-4 FRAME

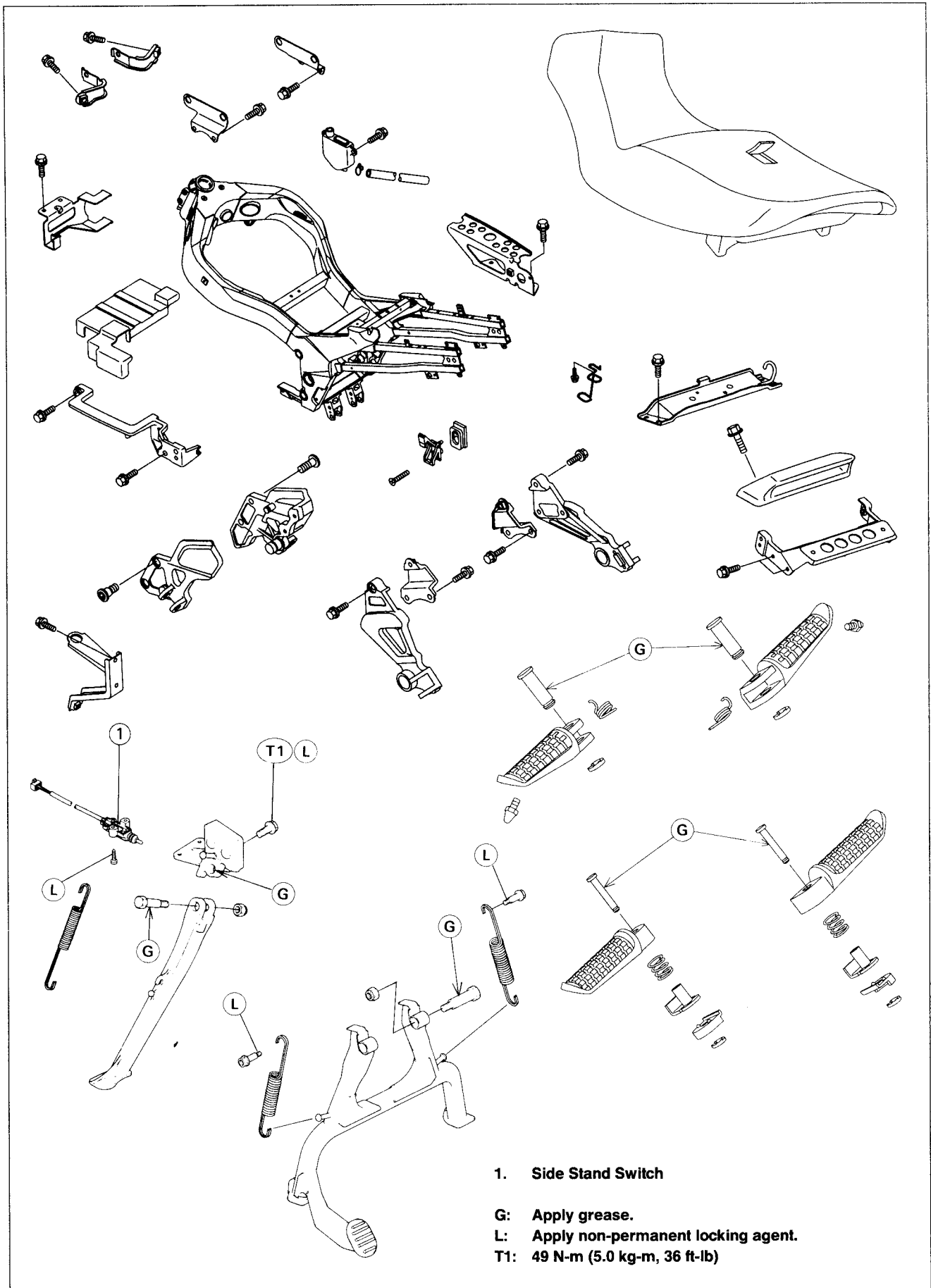

1. Side Stand Switch

G: Apply grease.

L: Apply non-permanent locking agent.

T1: 49 N-m (5.0 kg-m, 36 ft-lb)

Fairing

Lower Fairing Removal

- Remove the fasteners[A], reflector[B] and take off the left and right fenders[C] together.

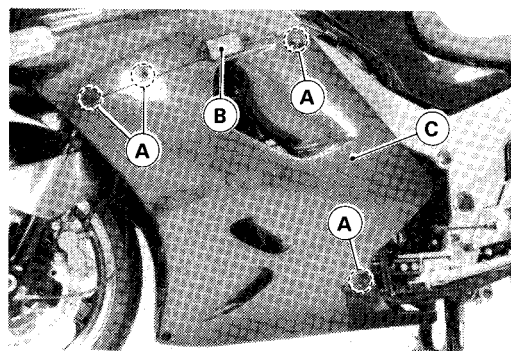

Inner and Upper Fairings

- Remove the screws[A] and take off the wind shield [B].

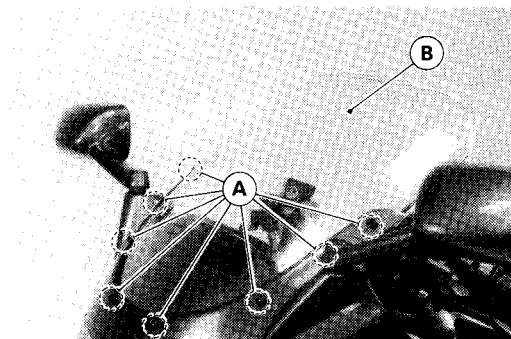

- Remove the screws[A] and take off the inner front fairing [B].

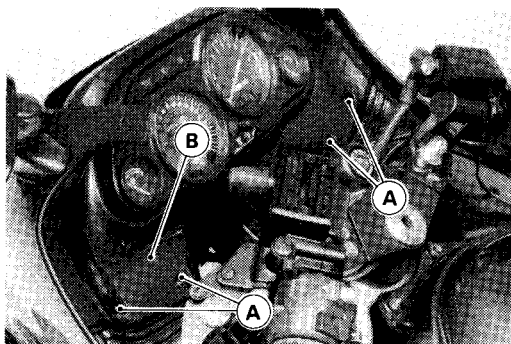

- Remove the seat.
- Remove the fuel tank (see Fuel System chapter).
- Remove the screws[A], Allen bolt[B] and take off the inner rear fairing[C].

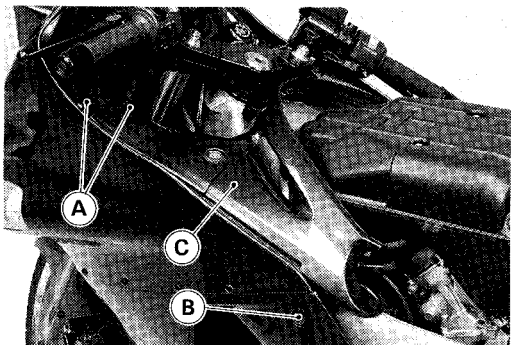

Upper Fairing Removal

- Remove the nuts[A] and take off the left and right [B] rear view mirrors.

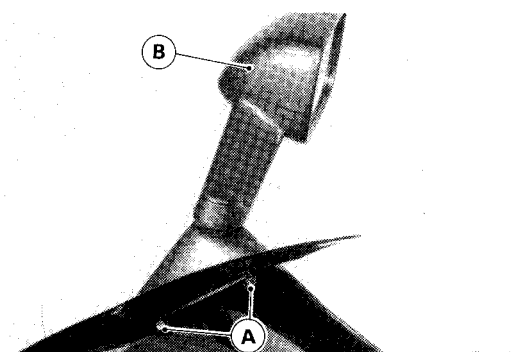

14-6 FRAME

- Loosen the air duct clamp bolt and pull out the upper fairing slightly then disconnect the headlight lead connector[A] from the main harness.
- Pull out the upper fairing with the headlight, turn signal lights and air ducts mounted on it.

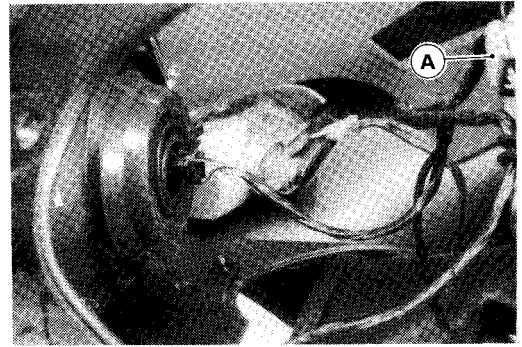

Side Cover and Tail Cover Removal

- Remove the seat.
- Remove the Allen bolts[A] and take off the passenger grab rail[B].

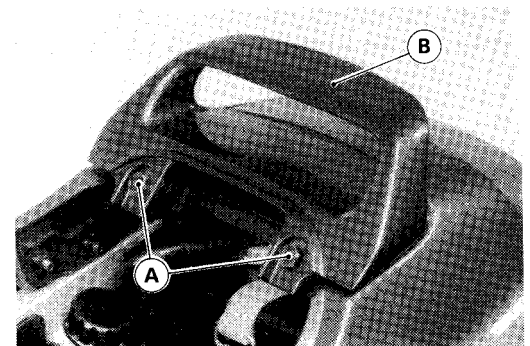

- Remove the side cover mounting screws[A], tying hooks [B] and tail cover screws[C].

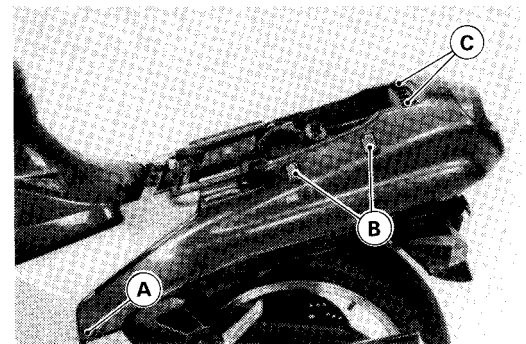

- Remove the screw[A] and separate the rear end of left [B] from the right [C] side covers at the notch [D].
- Disconnect the rear turn signal lead connector on each side cover.

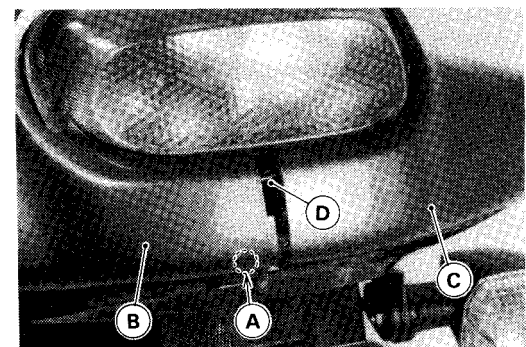

Rear Fender Removal

● Remove the following.

- Seat
- Fuel Tank
- Side Covers
- Tail Cover
- Wiring Harness
- Oil Hose Clamp
- Battery [A]
- Junction Box [B]
- IC Igniter [C]
- Turn Signal Relay

- Rear Fender Rear [A]
- Mounting Bolts [B]
- Rear Wheel

- Rear Fender Front [A]
- [B] Mounting Bolts

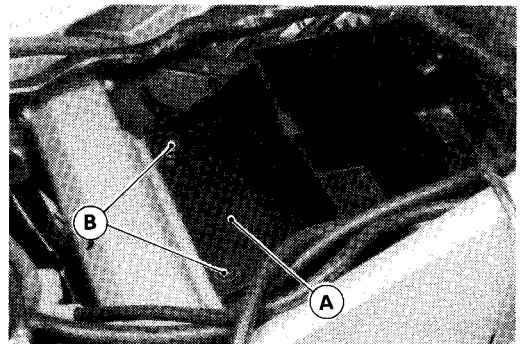
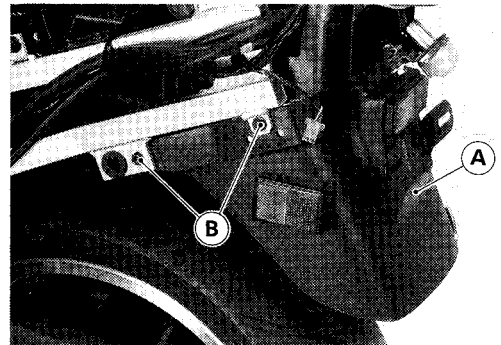
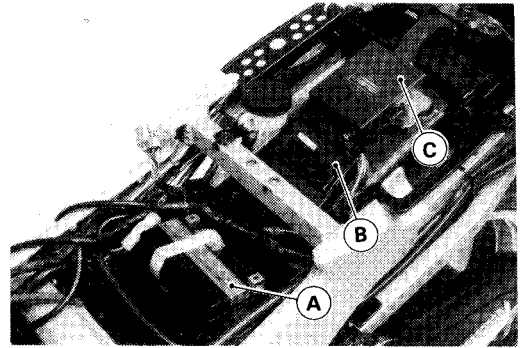

Electrical System

Table of Contents

Parts Location	15-2	Disassembly	15-30
Exploded View	15-3	Assembly	15-31
Specifications	15-6	Brush Inspection	15-32
Wiring Diagram	15-7	Commutator Cleaning and Inspection	15-32
Precautions	15-13	Armature Inspection	15-32
Electrical Wiring	15-14	Negative Brush and Lead Assembly	
Inspection	15-14	Inspection	15-33
Battery	15-15	Brush Plate Inspection	15-33
Electrolyte Level Inspection	15-15	Starter Relay Inspection	15-33
Electrolyte Specific Gravity Inspection	15-15	Electric Starter System Circuit	15-34
Initial Charging	15-15	Headlight	15-35
Ordinary Charging	15-16	Headlight Bean Horizontal Adjustment	15-35
Alternator	15-17	Headlight Beam Vertical Adjustment	15-35
Removal	15-17	Headlight Bulb Replacement Notes	15-36
Installation	15-17	Headlight Circuit Inspection	15-36
Disassembly	15-17	Fuel Pump	15-38
Assembly	15-18	Removal/Installation	15-38
Starter Coil Inspection	15-19	Fuel Pump Relay Internal Resistance	15-38
Rotor Coil Inspection	15-19	Check for Proper Operation	15-38
Slip Ring Cleaning	15-19	Fuel Pump Circuit	15-39
Slip Ring Diameter	15-19	Cooling Fan System	15-40
Carbon Brush Length	15-19	Fan System Circuit Inspection	15-40
Rectifier Inspection	15-20	Fan Inspection	15-40
Regulator Inspection	15-20	Fan Switch Inspection	15-40
Alternator Troubleshooting:	15-21	Meters, Gauge	15-41
Test No.1 - Battery Discharged	15-21	Meter Removal	15-41
Test No.2 - Battery Overcharged	15-22	Tachometer Inspection	15-41
Test No.3 - Noise	15-22	Fuel Level Sensor Inspection	15-42
Ignition System	15-23	Fuel Level Sensor Operation Circuit	15-42
Pickup Coil Removal	15-23	Water Temperature Gauge	
Pickup Coil Installation	15-23	Operation Inspection	15-43
Pickup Coil Inspection	15-24	Water Temperature Gauge	
Ignition Coil Removal/Installation	15-24	Operation Circuit	15-43
Ignition Coil Inspection	15-24	Water Temperature Sensor Inspection	15-44
Spark Plug Removal/Inspection	15-26	Junction Box	15-45
Spark Plug Cleaning and Inspection	15-26	Fuse Removal	15-45
Spark Plug Gap Inspection	15-26	Fuse Installation Note	15-45
IC Igniter Inspection	15-26	Fuse Inspection	15-45
Ignition System Troubleshooting	15-27	Fuse Circuit Inspection	15-45
Electric Starter System	15-30	Headlight/Starter Circuit Relay	
Starter Motor Removal	15-30	Inspection	15-46
Starter Motor Installation	15-30	Diode Circuit Inspection	15-46

15-2 ELECTRICAL SYSTEM

Parts Location

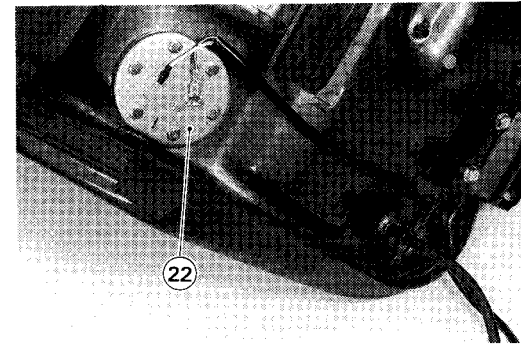
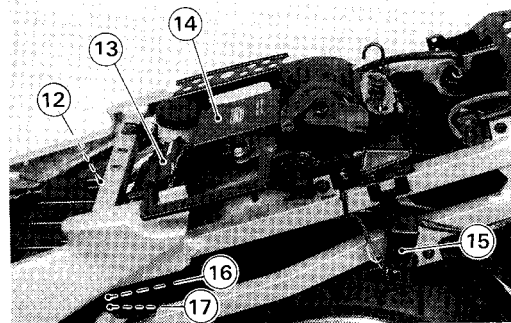
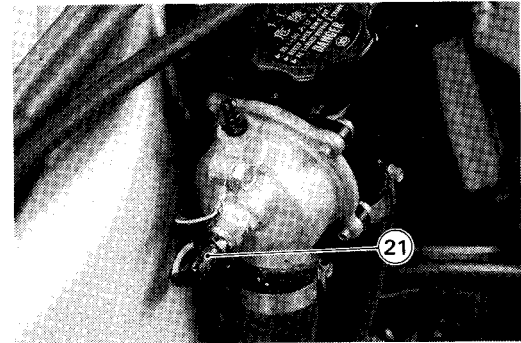
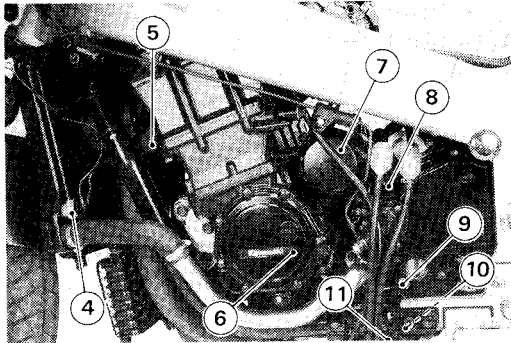
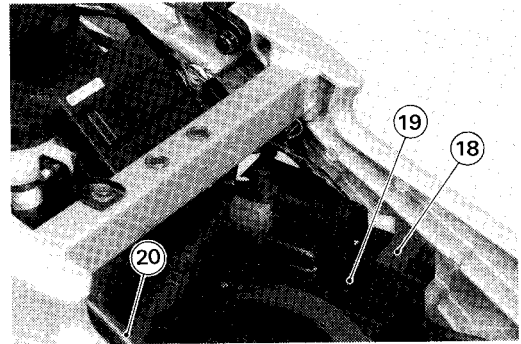
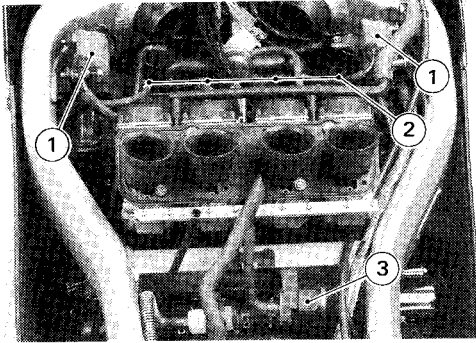

- 1. Ignition Coils
- 2. Spark Plugs
- 3. Fuel Pump
- 4. Radiator Fan Switch
- 5. Radiator Fan
- 6. Pickup Coil
- 7. Alternator
- 8. Starter Motor

- 9. Neutral Switch
- 10. Oil Pressure Switch
- 11. Side Stand Switch
- 12. Diode
- 13. Junction Box
- 14. IC Igniter
- 15. Turn Signal Relay
- 16. Starter Relay

- 17. Main Fuse
- 18. Fuel Pump Relay
- 19. Battery
- 20. Rear Brake Light Switch
- 21. Water Temperature Sensor
- 22. Fuel Level Sensor

Exploded View

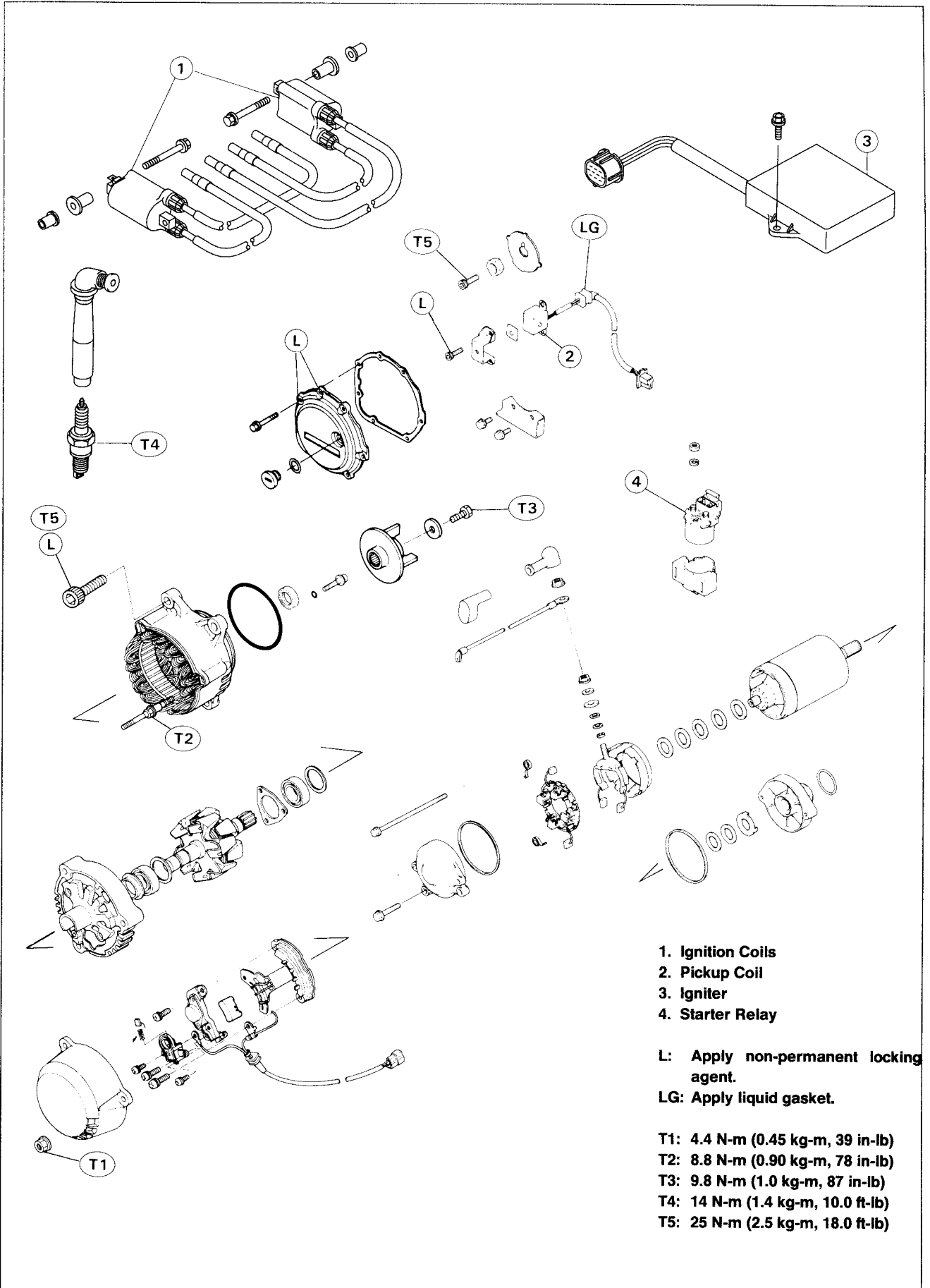

- 1. Ignition Coils
- 2. Pickup Coil
- 3. Igniter
- 4. Starter Relay

L: Apply non-permanent locking agent.
 LG: Apply liquid gasket.

- T1: 4.4 N-m (0.45 kg-m, 39 in-lb)
- T2: 8.8 N-m (0.90 kg-m, 78 in-lb)
- T3: 9.8 N-m (1.0 kg-m, 87 in-lb)
- T4: 14 N-m (1.4 kg-m, 10.0 ft-lb)
- T5: 25 N-m (2.5 kg-m, 18.0 ft-lb)

15-4 ELECTRICAL SYSTEM

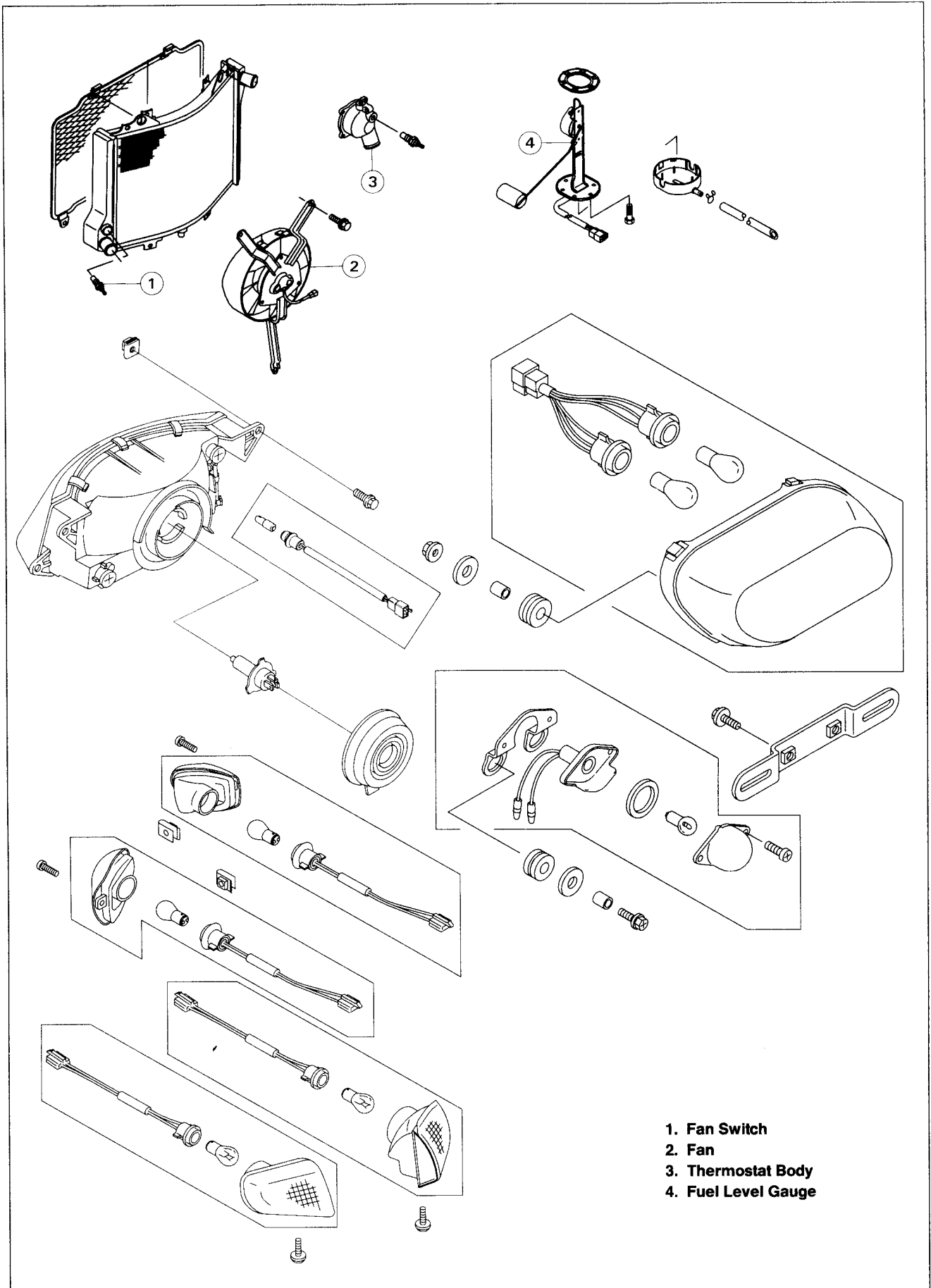

- 1. Fan Switch
- 2. Fan
- 3. Thermostat Body
- 4. Fuel Level Gauge

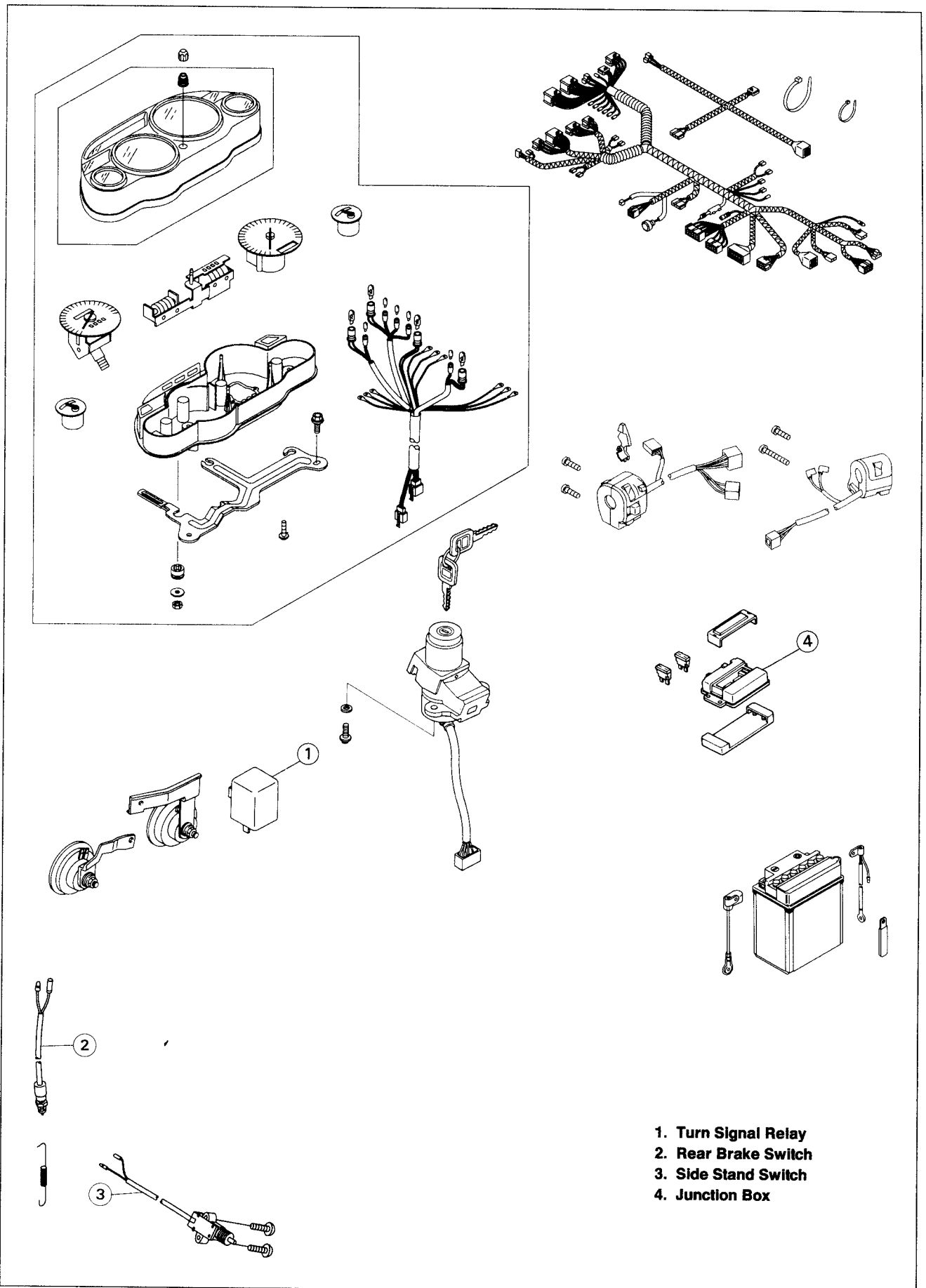

1. Turn Signal Relay
2. Rear Brake Switch
3. Side Stand Switch
4. Junction Box

15-6 ELECTRICAL SYSTEM

Specifications

Item	Standard	Service Limit
Battery: Type Specific gravity	12 V 12 Ah 1.280 @20°F (68°F)	---
Alternator: Changing voltage Rotor coil resistance Stator coil resistance Slip ring diameter Carbon brush length	14.5, Night @4 000 r/min(rpm) About 4 Ω Less than 1.0 Ω 14.4 mm 10.5 mm	--- --- 14.0 mm 4.5 mm
Ignition System: Pickup coil air gap Pickup coil resistance Ignition coil: 3 needle arcing distance Primary winding resistance Secondary winding resistance Spark plug: Standard plug Plug gap	0.7 mm 380 ~ 570 Ω 6 mm or more 2.3 ~ 3.5 Ω 12 ~ 18 kΩ NGK CR9E or ND U27ESR-N, (U) NGK C9E or ND U27ES-N 0.7 ~ 0.8 mm	--- --- --- --- --- ---
Electric Starter System: Starter Motor carbon brush length Starter Motor commutator diameter	12.0 ~ 12.5 mm 28 mm	6 mm 27 mm
Cooling Fan System: Fan switch: OFF → ON ON → OFF	93~103°C (199~217°F) 91~95°C (196~203°F)	--- ---
Meter Gauge: Water temperature sensor resistance	80°C (176°F) : about 52 Ω 100°C (212°F) : about 27 Ω	--- ---

(U) : US Model

Special Tool – Hand Tester: 57001-983

Coil Tester: 57001-1242

Spark Plug Wrench, Hex 16: 57001-1262

Kawasaki Bond (Silicone Sealant): 56019-120

Kawasaki Bond (Liquid Gasket – Black): 92104-1003

ZX1100-D1, D2 Wiring Diagram (US, Canada)

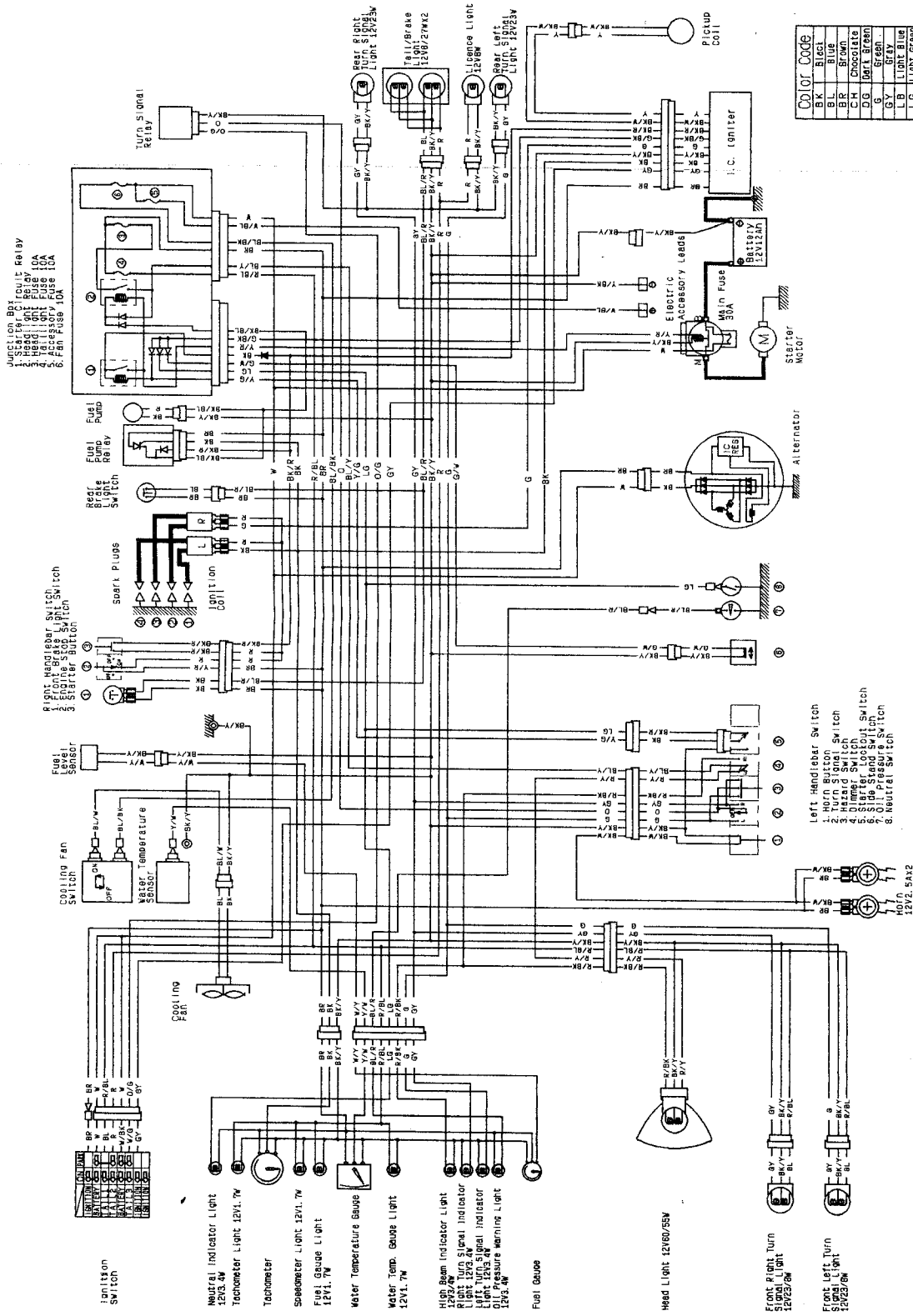

JUNCTION BOX
 1. Starter Relay
 2. Fuel Pump Relay
 3. Ignition Switch
 4. Turn Signal Relay
 5. Fuel Pump Relay
 6. Fan Relay

RIGHT HANDLEBAR SWITCH CONNECTIONS
 1. Ignition Switch
 2. Starter Button
 3. Starter Relay

COOLING FAN SWITCH CONNECTIONS
 1. Fan Relay
 2. Fan Fuse

WATER TEMPERATURE SENSOR CONNECTIONS
 1. Water Temp. Gauge
 2. Water Temp. Sensor

IGNITION SWITCH CONNECTIONS
 1. Ignition Switch
 2. Starter Motor
 3. Ignition Coil
 4. Turn Signal
 5. High Beam Indicator
 6. Neutral Indicator
 7. Fuel Gauge
 8. Water Temp. Gauge
 9. Headlight
 10. Rear Brake Light

NEUTRAL INDICATOR LIGHT CONNECTIONS
 1. Neutral Indicator Light
 2. Neutral Switch

TACHOMETER LIGHT CONNECTIONS
 1. Tachometer Light
 2. Tachometer

SPEEDOMETER LIGHT CONNECTIONS
 1. Speedometer Light
 2. Speedometer

FUEL GAUGE LIGHT CONNECTIONS
 1. Fuel Gauge Light
 2. Fuel Gauge

WATER TEMPERATURE GAUGE CONNECTIONS
 1. Water Temp. Gauge
 2. Water Temp. Sensor

WATER TEMP. GAUGE LIGHT CONNECTIONS
 1. Water Temp. Gauge Light
 2. Water Temp. Gauge

HIGH BEAM INDICATOR LIGHT CONNECTIONS
 1. High Beam Indicator Light
 2. High Beam Switch

RIGHT TURN SIGNAL INDICATOR LIGHT CONNECTIONS
 1. Right Turn Signal Indicator Light
 2. Right Turn Signal Switch

LEFT TURN SIGNAL INDICATOR LIGHT CONNECTIONS
 1. Left Turn Signal Indicator Light
 2. Left Turn Signal Switch

OLL PRESSURE WARNING LIGHT CONNECTIONS
 1. Oil Pressure Warning Light
 2. Oil Pressure Sensor

FUEL GAUGE CONNECTIONS
 1. Fuel Gauge
 2. Fuel Tank

HEAD LIGHT CONNECTIONS
 1. Headlight
 2. Headlight Switch

FRONT FRONT TURN SIGNAL LIGHT CONNECTIONS
 1. Front Turn Signal Light
 2. Front Turn Signal Switch

FRONT LEFT TURN SIGNAL LIGHT CONNECTIONS
 1. Front Left Turn Signal Light
 2. Front Left Turn Signal Switch

FRONT RIGHT TURN SIGNAL LIGHT CONNECTIONS
 1. Front Right Turn Signal Light
 2. Front Right Turn Signal Switch

REAR BRAKE LIGHT CONNECTIONS
 1. Rear Brake Light
 2. Rear Brake Switch

REAR LIGHT CONNECTIONS
 1. Rear Light
 2. Rear Light Switch

REAR TURN SIGNAL LIGHT CONNECTIONS
 1. Rear Turn Signal Light
 2. Rear Turn Signal Switch

REAR TURN SIGNAL LIGHT CONNECTIONS
 1. Rear Turn Signal Light
 2. Rear Turn Signal Switch

REAR TURN SIGNAL LIGHT CONNECTIONS
 1. Rear Turn Signal Light
 2. Rear Turn Signal Switch

REAR TURN SIGNAL LIGHT CONNECTIONS
 1. Rear Turn Signal Light
 2. Rear Turn Signal Switch

REAR TURN SIGNAL LIGHT CONNECTIONS
 1. Rear Turn Signal Light
 2. Rear Turn Signal Switch

REAR TURN SIGNAL LIGHT CONNECTIONS
 1. Rear Turn Signal Light
 2. Rear Turn Signal Switch

REAR TURN SIGNAL LIGHT CONNECTIONS
 1. Rear Turn Signal Light
 2. Rear Turn Signal Switch

REAR TURN SIGNAL LIGHT CONNECTIONS
 1. Rear Turn Signal Light
 2. Rear Turn Signal Switch

Color	Code
BK	Black
BL	Blue
BR	Brown
CH	Chocolate
CO	Copper
GY	Gray
LG	Light Green
LB	Light Blue
LG	Light Green
P	Orange
PO	Pink
PU	Purple
RD	Red
W	White
Y	Yellow

Color	Code
W	White
BL	Blue
BR	Brown
GY	Gray
LG	Light Green
LB	Light Blue
LG	Light Green
P	Orange
PO	Pink
PU	Purple
RD	Red
W	White
Y	Yellow

Color	Code
W	White
BL	Blue
BR	Brown
GY	Gray
LG	Light Green
LB	Light Blue
LG	Light Green
P	Orange
PO	Pink
PU	Purple
RD	Red
W	White
Y	Yellow

Color	Code
W	White
BL	Blue
BR	Brown
GY	Gray
LG	Light Green
LB	Light Blue
LG	Light Green
P	Orange
PO	Pink
PU	Purple
RD	Red
W	White
Y	Yellow

Color	Code
W	White
BL	Blue
BR	Brown
GY	Gray
LG	Light Green
LB	Light Blue
LG	Light Green
P	Orange
PO	Pink
PU	Purple
RD	Red
W	White
Y	Yellow

(98051-338A1)

15-10 ELECTRICAL SYSTEM
ZX1100-D3 Wiring Diagram (US, Canada)

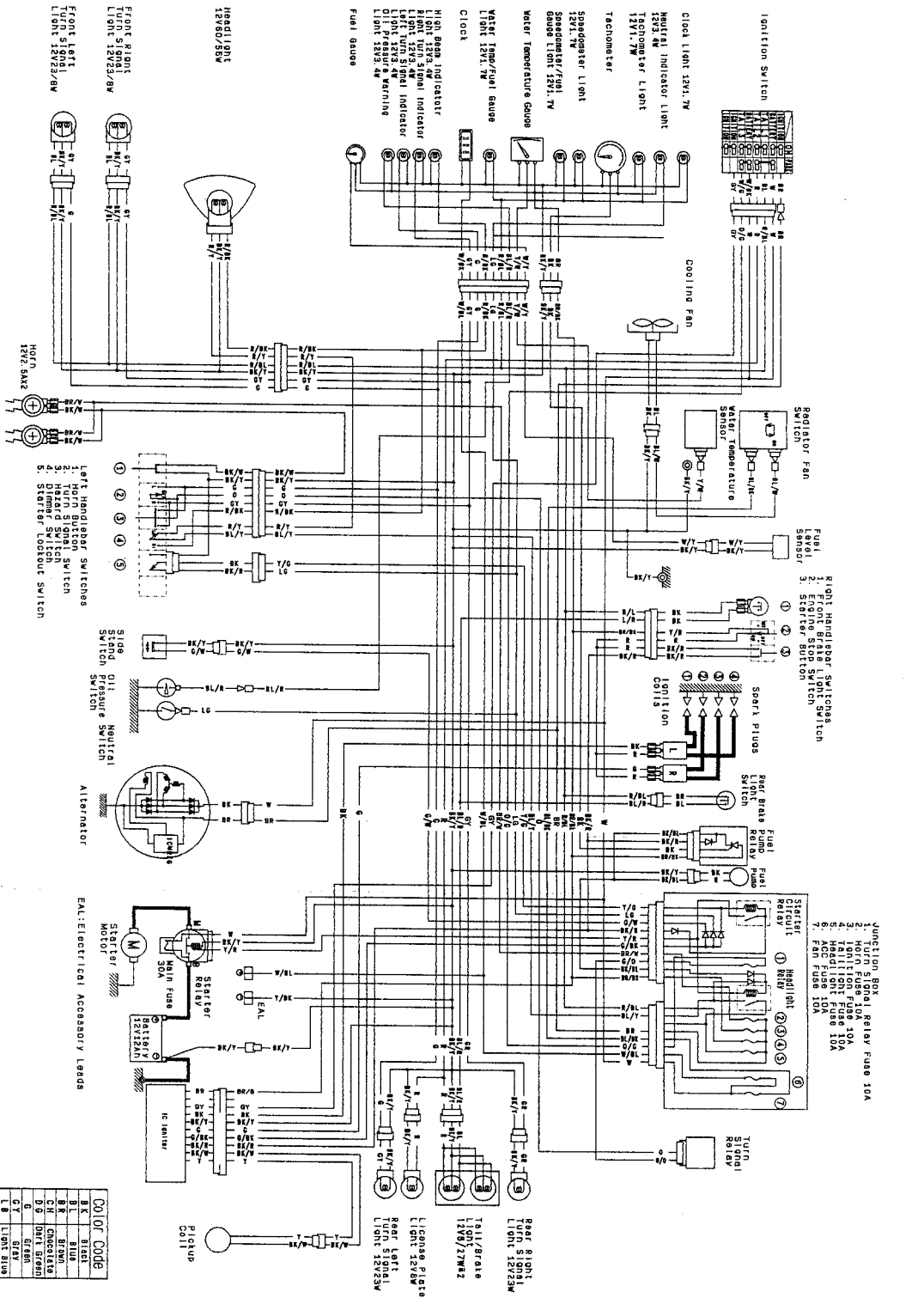

- Fuel Relay
Label
1. Front Brake Light Switch
2. Starter Solenoid

- Junction Box - Relay Fuse 10A
1. Horn Fuse 10A
2. Ignition Fuse 10A
3. Front Signal Light Fuse 10A
4. Headlight Fuse 10A
5. Fuel Fuse 10A
6. FFC Fuse 10A

1. Left Handgear Switches
2. Horn Signal Switch
3. Dimmer Switch
4. Dimmer Switch
5. Starter Lockout Switch

1. Headlight
2. 3
3. 4
4. 5
5. 6
6. 7
7. 8
8. 9
9. 10
10. 11
11. 12
12. 13
13. 14
14. 15
15. 16
16. 17
17. 18
18. 19
19. 20
20. 21
21. 22
22. 23
23. 24
24. 25
25. 26
26. 27
27. 28
28. 29
29. 30
30. 31
31. 32
32. 33
33. 34
34. 35
35. 36
36. 37
37. 38
38. 39
39. 40
40. 41
41. 42
42. 43
43. 44
44. 45
45. 46
46. 47
47. 48
48. 49
49. 50
50. 51
51. 52
52. 53
53. 54
54. 55
55. 56
56. 57
57. 58
58. 59
59. 60
60. 61
61. 62
62. 63
63. 64
64. 65
65. 66
66. 67
67. 68
68. 69
69. 70
70. 71
71. 72
72. 73
73. 74
74. 75
75. 76
76. 77
77. 78
78. 79
79. 80
80. 81
81. 82
82. 83
83. 84
84. 85
85. 86
86. 87
87. 88
88. 89
89. 90
90. 91
91. 92
92. 93
93. 94
94. 95
95. 96
96. 97
97. 98
98. 99
99. 100

LEFT HANDGEAR SWITCH CONNECTIONS

HOIN BUTTON	TURN SIGNAL SWITCH	STARTER LOCKOUT SWITCH	HORN SIGNAL SWITCH	IGNITION SWITCH
Color: B/W	Color: G	Color: R/W	Color: B/W	Color: G
Position: R	Position: L	Position: R	Position: L	Position: L
Terminal: 1	Terminal: 2	Terminal: 3	Terminal: 4	Terminal: 5

IGNITION SWITCH CONNECTIONS

Color	W	R	W	R	W	R	W	R	W	R
Ignition	Ignition	Ignition	Ignition	Ignition	Ignition	Ignition	Ignition	Ignition	Ignition	Ignition
Position: ON	Position: ON	Position: ON	Position: ON	Position: ON	Position: ON	Position: ON	Position: ON	Position: ON	Position: ON	Position: ON
Terminal: 1	Terminal: 2	Terminal: 3	Terminal: 4	Terminal: 5	Terminal: 6	Terminal: 7	Terminal: 8	Terminal: 9	Terminal: 10	Terminal: 11

RIGHT HANDGEAR SWITCH CONNECTIONS

Color	BK	BL	GR	WH	Y
Front Brake Light Switch	Front Brake Light Switch	Front Brake Light Switch	Front Brake Light Switch	Front Brake Light Switch	Front Brake Light Switch
Position: OFF	Position: OFF	Position: OFF	Position: OFF	Position: OFF	Position: OFF
Terminal: 1	Terminal: 2	Terminal: 3	Terminal: 4	Terminal: 5	Terminal: 6

COLOR CODE

Color	Code
Black	BK
Blue	BL
Brown	BR
Green	GR
Orange	OR
Red	R
White	W
Yellow	Y

(9405-1-1482)C

ZX1100-D3 Wiring Diagram (Other than US, Canada and Australia)

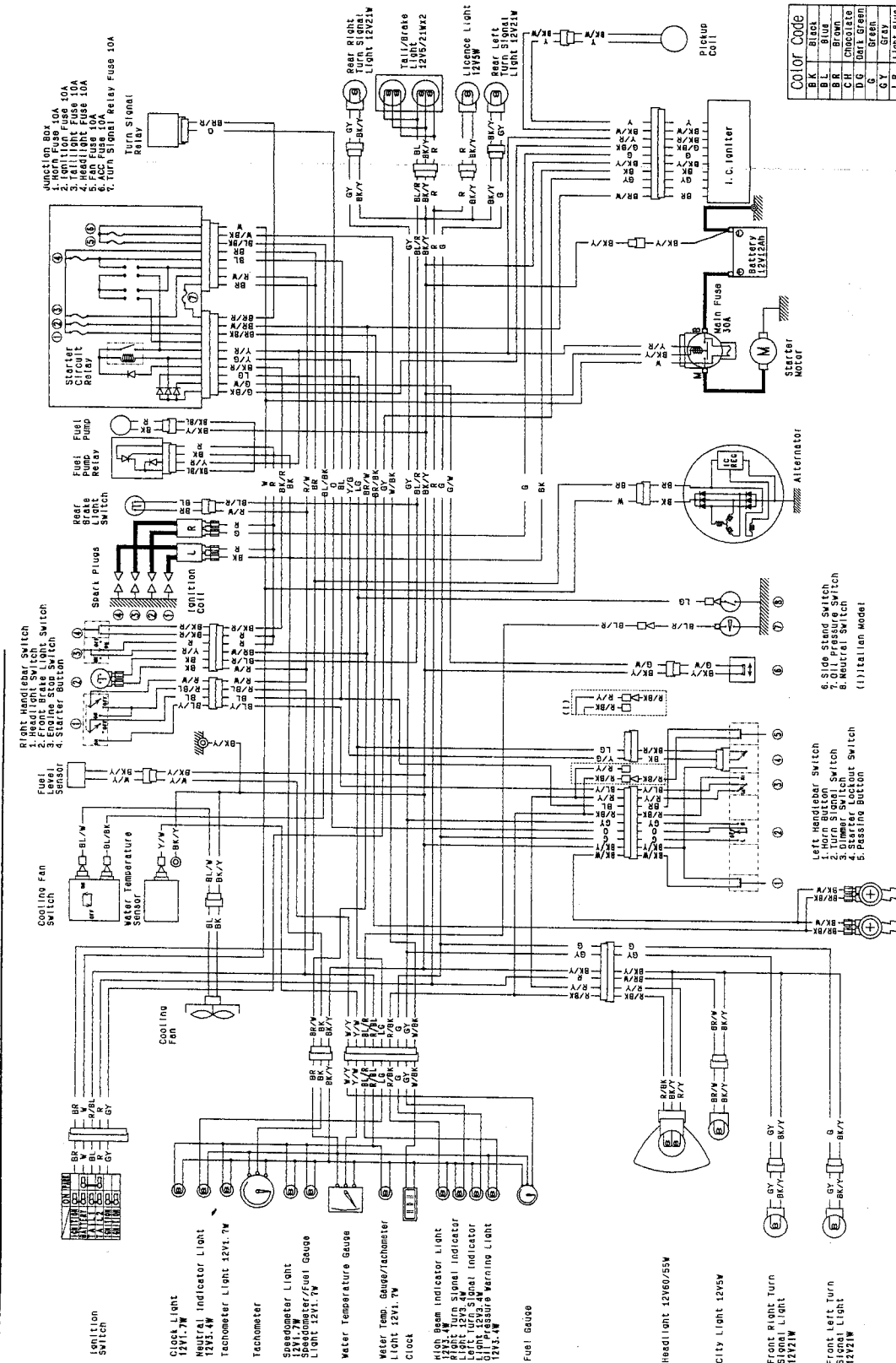

COLOR CODE

BK	Black
BL	Blue
BR	Brown
BU	Blue
CH	Chrome/Al
DG	Dark Green
G	Green
GY	Gray
LB	Light Blue
LG	Light Green
OR	Orange
PU	Purple
R	Red
RD	Red
W	White
Y	Yellow

RIGHT HANDLEBAR SWITCH CONNECTIONS

Color	Ignition Switch	Passing Switch	Turn Signal Switch	Engine Stop Switch	Starter Button
Color	BR/W	R/BL/W	Color	BK	BK
OFF/LOCK	ON	Push	OFF	Y/R	R
ON	ON	Push	ON	ON	Push

(99051-1484B, 1485A) C

IGNITION SWITCH CONNECTIONS

Color	Ignition Switch	Passing Switch	Turn Signal Switch	Engine Stop Switch	Starter Button
Color	BR	W	GT	BL	R
OFF/LOCK	ON	ON	ON	ON	ON
ON	ON	ON	ON	ON	ON

LEFT HANDLEBAR SWITCH CONNECTIONS

Color	Ignition Switch	Passing Switch	Turn Signal Switch	Engine Stop Switch	Starter Button
Color	GY	Color	R/Y	BL/W/BK	BR/BK
Released	Released	Released	Released	Released	Released
Push	Push	Push	Push	Push	Push

RIGHT HANDLEBAR SWITCH CONNECTIONS

Color	Ignition Switch	Passing Switch	Turn Signal Switch	Engine Stop Switch	Starter Button
Color	BR/W	R/BL/W	Color	BK	BK
OFF/LOCK	ON	ON	OFF	Y/R	R
ON	ON	ON	ON	ON	ON

LEFT HANDLEBAR SWITCH CONNECTIONS

Color	Ignition Switch	Passing Switch	Turn Signal Switch	Engine Stop Switch	Starter Button
Color	GY	Color	R/Y	BL/W/BK	BR/BK
Released	Released	Released	Released	Released	Released
Push	Push	Push	Push	Push	Push

Precautions

There are numbers of important precautions that are musts when servicing electrical systems. Learn and observe all the rules below.

- Do not reverse the battery lead connections. This will burn out the diodes in the electrical parts.
- Always check battery condition before condemning other parts of an electrical system. A fully charged battery is a must for conducting accurate electrical system tests.
- The electrical parts should never be struck sharply, as with a hammer, or allowed to fall on a hard surface. Such a shock to the parts can damage them.
- To prevent damage to electrical parts, do not disconnect the battery leads or any other electrical connections when the ignition switch is on, or the engine is running.
- Do not use a meter illumination bulb rated for other than the voltage or wattage specified in the wiring diagram, as the meter or gauge panel could be warped by excessive heat radiated from the bulb.
- Take care not to short the leads that are directly connected to the battery positive (+) terminal to the chassis ground.
- Troubles may involve one or in some cases all items. Never replace a defective part without determining what CAUSED the failure. If the failure is caused by some other item or items, they too must be repaired or replaced, or the new replacement will soon fail again.
- Make sure all connectors in the circuit are clean and tight, and examine wires for signs of burning, fraying, etc. Poor wires and bad connections will affect electrical system operation.
- Measure coil and winding resistance when the part is cold (at room temperature).
- Color Codes:
 - BK Black
 - BL Blue
 - BR Brown
 - CH Chocolate
 - DG Dark green
 - G Green
 - GY Gray
 - LB Light blue
 - LG Light green
 - O Orange
 - P Pink
 - PU Purple
 - R Red
 - W White
 - Y Yellow

○ Electrical Connectors

[A] Female Connectors

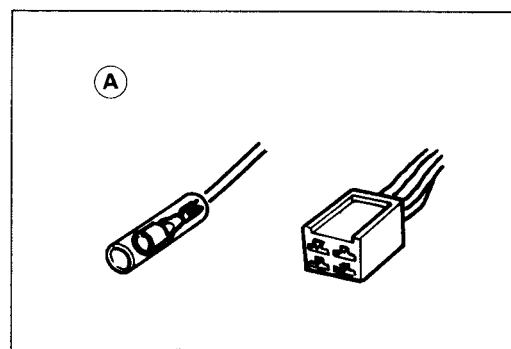

[B] Male Connectors

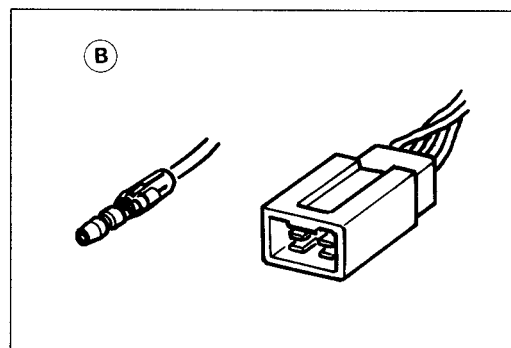

15-14 ELECTRICAL SYSTEM

Electrical Wiring

Inspection

- Visually inspect the wiring for signs of burning, fraying, etc.
- ★ If any wiring is poor, replace the damaged wiring.
- Pull each connector apart and inspect it for corrosion, dirt, and damage.
- ★ If the connector is corroded or dirty, clean it carefully. If it is damaged, replace it.
- Check the wiring for continuity.
- Use the wiring diagram to find the ends of the lead which is suspected of being a problem.
- Connect an ohmmeter between the ends of the lead.
- Set the meter to the $\times 1\ \Omega$ range, and read the meter.
- ★ If the meter does not read $0\ \Omega$, the lead is defective. Replace the lead or the wiring harness if necessary.

Battery

Electrolyte Level inspection

- The electrolyte level should be between the upper and the lower level lines.
- ★ If the level of electrolyte in any cell is below the lower level line [B] add only distilled water to cell, until the level is at the upper level line [A].

CAUTION

Ordinary tap water is not a substitute for distilled water and will shorten the life of the battery.

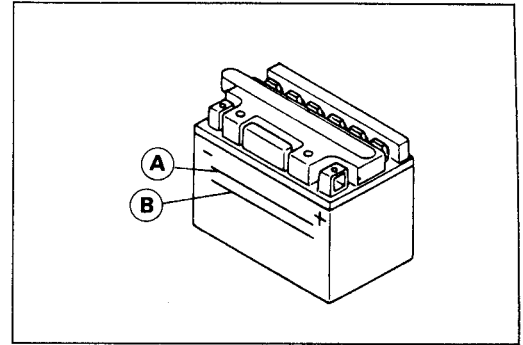

Electrolyte Specific Gravity Inspection

- Check battery condition by testing the specific gravity of the electrolyte in each cell with a hydrometer.
- Read the level of the electrolyte on the floating scale [A].
- ★ If the specific gravity is below 1.20 (charge 60%) the battery needs to be charged.

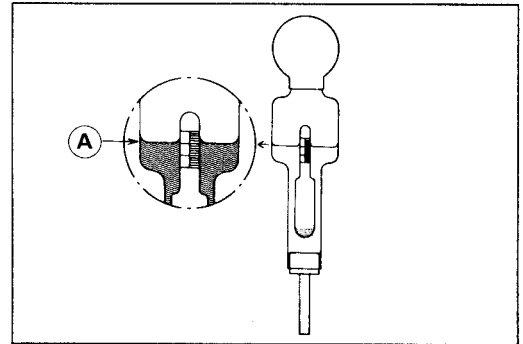

Initial Charging

⚠ WARNING

Keep the battery away from sparks and open flames during charging, since the battery gives off an explosive gas mixture of hydrogen and oxygen. When using a battery charger, connect the battery to the charger before turning on the charger. This procedure prevents sparks at the battery terminals which could ignite any battery gases.

- Fill each cell to the upper level line on the battery case with flash electrolyte (special gravity: 1.280) at a temperature of 30°C (86°F) or less. Let the battery stand for about 30 minutes before charging.

NOTE

○ If the electrolyte level drops, add electrolyte to the upper level line before charging.

- Set the charging rate at 1/10 the battery capacity, and **charge it for 10 hours**. For example, if the battery is rated at 12 Ah, the charging rate would be 1.2 A.

CAUTION

If the battery is not given a full initial charging, it will discharge in a few weeks. After that it can not be charged by supplement charging. Do not use a high rate battery charger, as is typically employed at automotive service stations, unless the charger rate can be reduced to the level required. Charging the battery at a rate higher than specified may ruin the battery. Charging at a high rate causes excess heat which can warp the plates and cause internal shorting. Higher- than-normal charging rates also cause the plates to shed active material. Deposits will accumulate, and can cause internal shorting.

If the temperature of the electrolyte rises above 45°C (115°F) during charging, reduce the charging rate to lower the temperature, and increase charging time proportionately.

15-16 ELECTRICAL SYSTEM

Ordinary Charging

⚠ WARNING

Keep the battery away from sparks and open flames during charging, since the battery gives off an explosive gas mixture of hydrogen and oxygen. When using a battery charger, connect the battery to the charger before turning on the charger. This procedure prevents sparks at the battery terminals which could ignite any battery gases.

CAUTION

Always remove the battery from the motorcycle for charging. If the battery is charged while still installed, battery electrolyte may spill and corrode the frame or other parts of the motorcycle.

CAUTION

Do not use a high rate battery charger, as is typically employed at automotive service stations, unless the charger rate can be reduced to the level required. Charging the battery at a rate higher than specified may ruin the battery. Charging at a high rate causes excess heat which can warp the plates and cause internal shorting. Higher-than-normal charging rates also cause the plates to shed active material. Deposits will accumulate, and can cause internal shorting.

If the temperature of the electrolyte rises above 45°C (115°F) during charging, reduce the charging rate to lower the temperature, and increase charging time proportionately.

- Check the electrolyte level after charging.

Battery Charging Rate/Time Table (12V 12Ah)

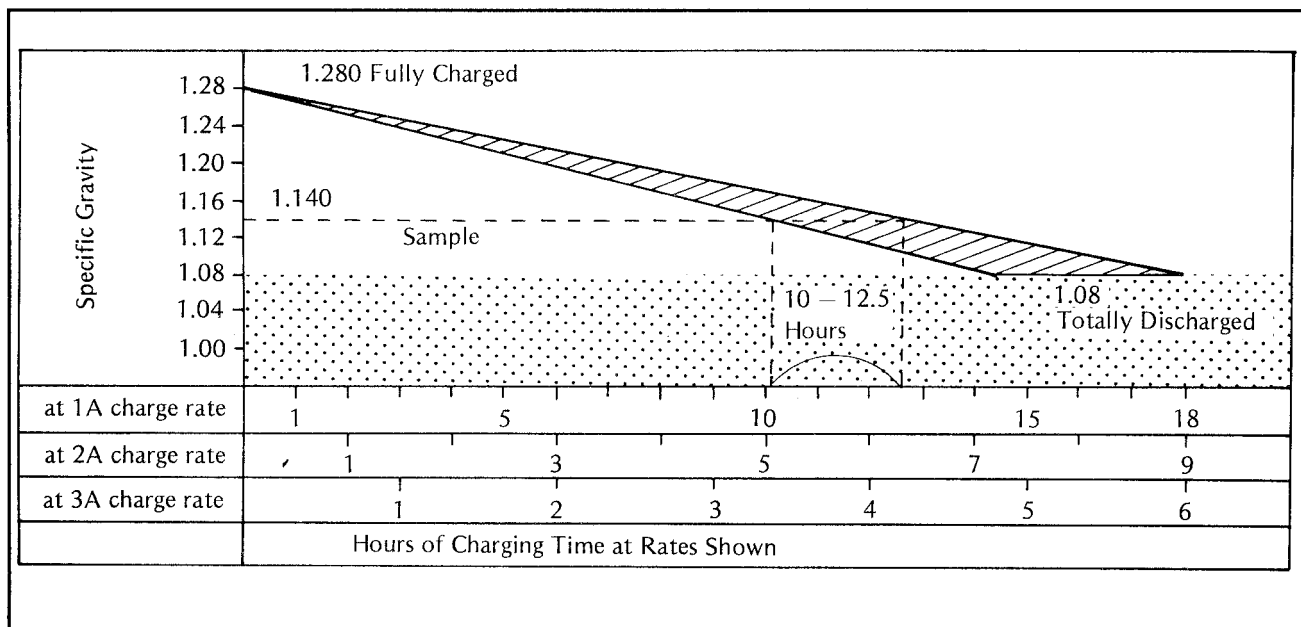

Alternator

Removal

NOTE

○ Alternator removal is not necessary to remove the rectifier, and carbon brush assembly. They can be removed often removing the alternator end cover.

- Remove the following.
 - Lower Fairings
 - Alternator Lead Connector
 - Alternator Mounting Bolts [A]
- Pull out the alternator [B].

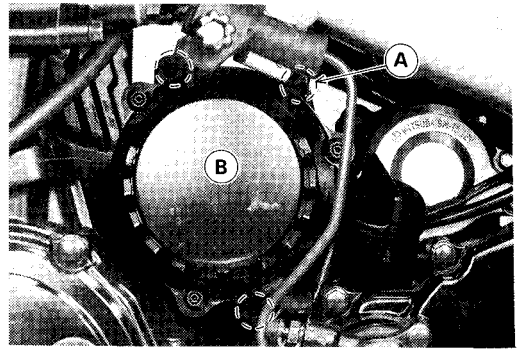

Installation

- Clean the alternator legs and crankcase where the alternator is grounded [B].
- Apply a small amount of engine oil to the rubber dampers and the O-ring [A].
- [C] Coupling Blades

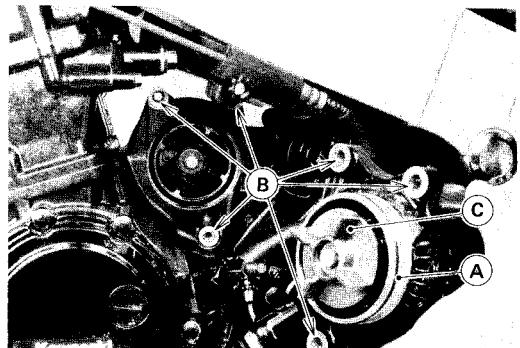

- Apply a non-permanent locking agent to the alternator mounting bolts, and tighten them.

Torque – Alternator Mounting Bolts: 25 N-m, (2.5 kg-m, 18.0 ft-lb)

CAUTION

If any resistance is felt when tightening the mounting bolts, stop, immediately, and check the alignment of the coupling blades with slots in the rubber dampers.

Disassembly

- Remove the following.
 - End Cover
 - Brush Assembly [A]
 - Rectifier [C]
 - Regulator [B]
- Unsolder the wires [D] on the rectifier.

NOTE

○ When unsoldering the alternator wires to the rectifier terminal, do it quickly. If high temperatures are applied for more than a few seconds, the rectifier's diodes may be damaged.

- Remove the bolt [B] and take off the alternator coupling [A].

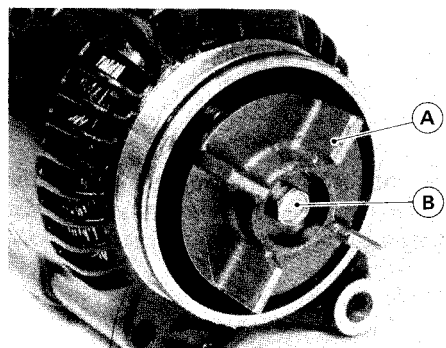
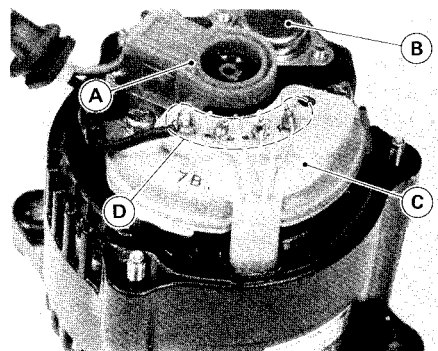

15-18 ELECTRICAL SYSTEM

- Remove the screws [B] and take off the stator housing [A].

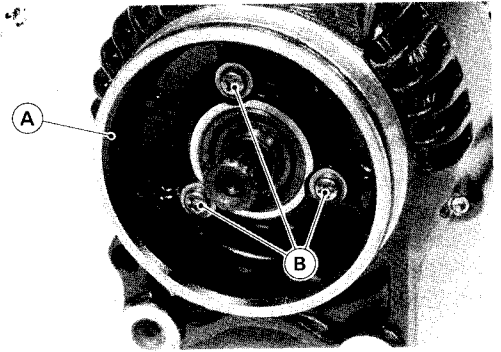

- Press out the rotor shaft [A] from the rotor housing.

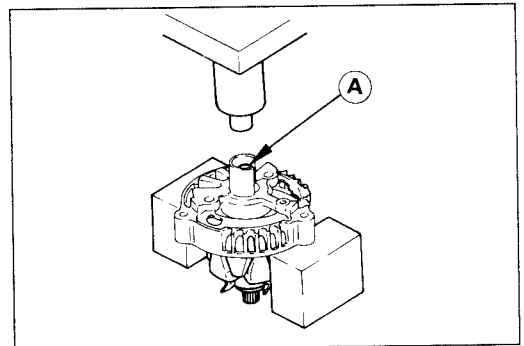

- To remove the ball bearing [B], from the rotor [A] use a suitable puller [C].

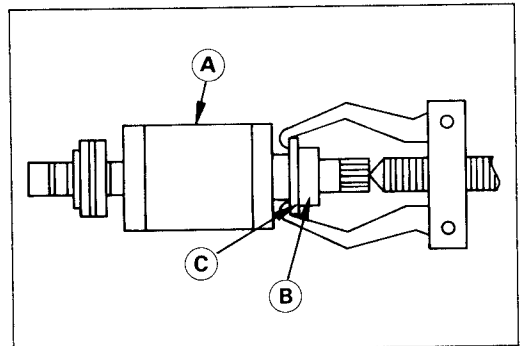

Assembly

- Assembly is the reverse of disassembly. Note the following.
- When installing the rotor bearing [A], press the bearing and bearing covers onto the rotor shaft [B]. The bearing short end from the bearing ring must face in.

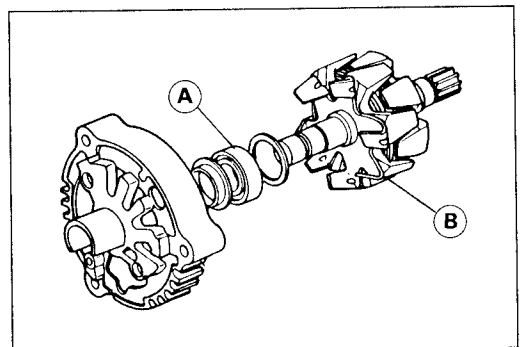

- Position the rotor bearing ring so that the projections of it [A] are aligned with the ring positioning groove [B].

[C] Rotor Bearing

NOTE

- When soldering the alternator wires to the rectifier terminal, do it quickly. If high temperatures are applied for more than a few seconds, the rectifier's diodes may be damaged.

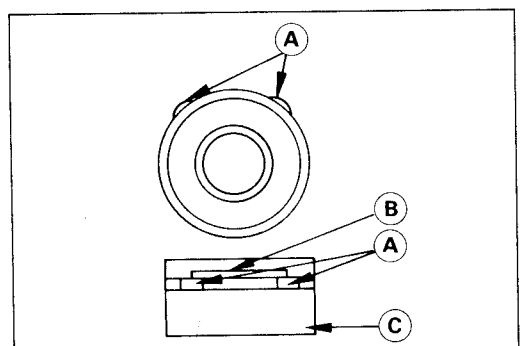

Stator Coil Inspection

- Connect an ohmmeter (× 1 Ω range) between the coil wires and read the meter.
- ★ If the meter does not read as specified, replace the stator coil.

Stator Coil Resistance

Less than 1.0 Ω

- Using the highest ohmmeter range, measure the resistance between the stator coil core and each of the coil windings.
- ★ If there is any reading at all, the stator coil winding has a short and must be replaced.

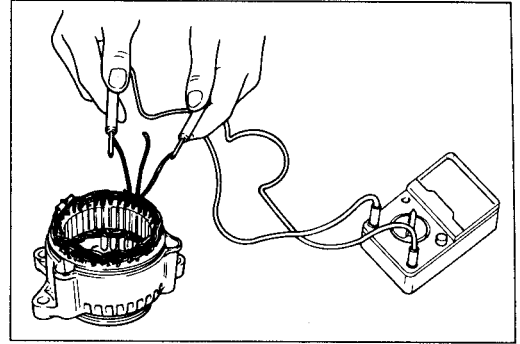

Rotor Coil Inspection

- Connect an ohmmeter (× 1 Ω range) between the slip rings [A] and read the meter.
- ★ If the meter does not read as specified, replace the rotor.

Rotor Coil Resistance

About 4 Ω

- Using the highest ohmmeter range measure the resistance between the rotor shaft and each of the slip rings.
- If there is any reading at all, the rotor coil has a short and must be replaced.

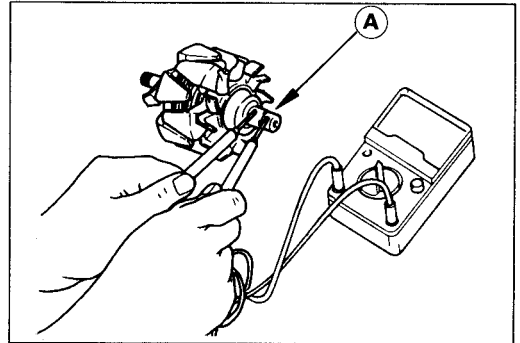

Slip Ring Cleaning

- Visually inspect the slip ring for dirt or pitting.
- ★ If necessary, smooth the slip ring with No. 300 – No. 500 emery cloth.

Slip Ring Diameter

- ★ If the measurement is less than the service limit, replace the rotor.

Slip Ring Diameter

Standard: 14.4 mm
Service Limit: 14.0 mm

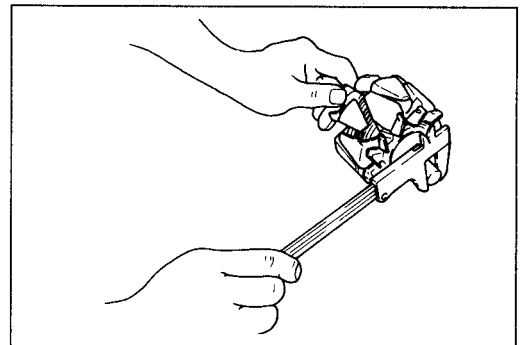

Carbon Brush Length

- Measure the length of both carbon brushes that stick out of the housing.
- If either one is worn down to less than the service limit replace it.

Carbon Brush Length (projected portion)

Standard: 10.5 mm
Service Limit: 4.5 mm

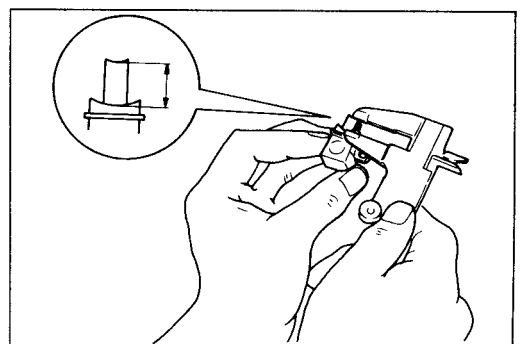

Rectifier Inspection

- Set an ohmmeter to the 1 k Ω range.
- Check the resistance of the diode in both directions.
- ★ If any diode shows low or high resistance in both directions, the diode is defective and the rectifier must be replaced.

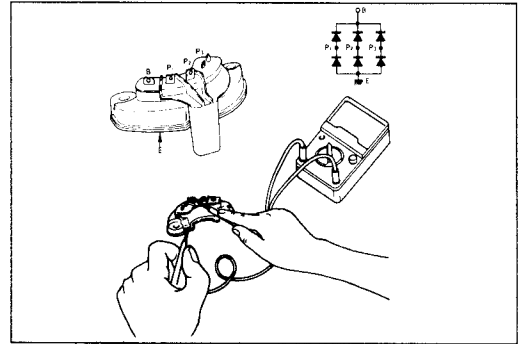

NOTE

- The actual meter reading varies with the meter used and the individual diode, but generally speaking, the lower reading should be from zero to half the scale.

CAUTION

If a megger or a meter with a large-capacity battery is used, the rectifier will be damaged.

Regulator Inspection

- Prepare testing tools.
 - Test light: Bulb rated 12V 3.4 W
 - Batteries: Two 12 V batteries
 - Test wires: Three auxiliary wires

CAUTION

The test light works as an indicator and also a current limiter to protect the regulator from excessive current. Do not use an ammeter instead of a test light.

- Connect the test light and the 12 V battery to the regulator as shown.
- The test light should go on at this time.

CAUTION

Do not contact the regulator metal case with the wires from the battery (+) or (-) terminal during the test.

- ★ If the test light does not go on, the regulator is damaged and must be replaced.

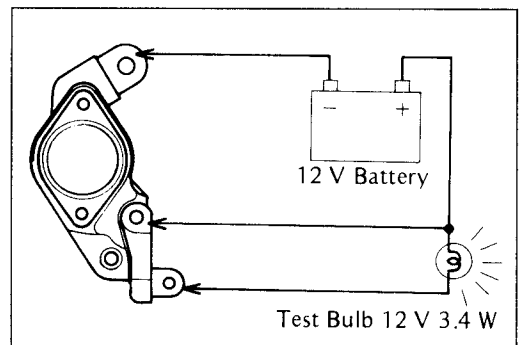

- Connect the test light and two 12 V batteries to the regulator as shown.
- The test light should not go on at this time.
- ★ If the test light goes on, the regulator is damaged and must be replaced.

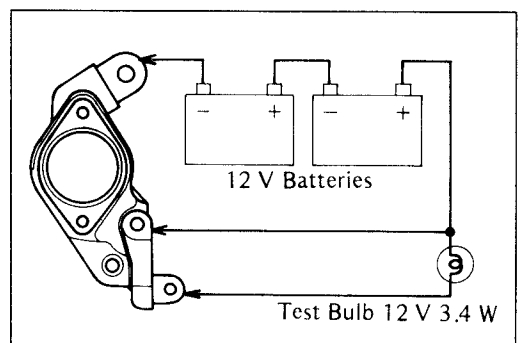

- Check the regulator internal resistance as shown.

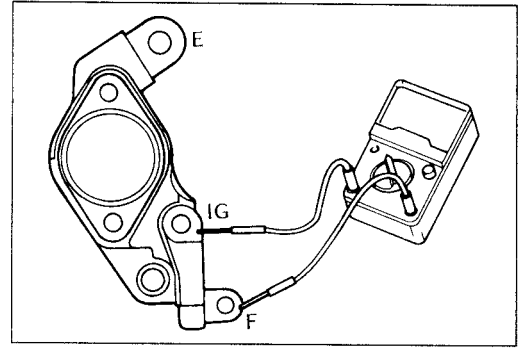

- ★ Meter readings should be nearly values shown in the table. If the resistance is infinity (no reading) or 0Ω , the regulator is damaged and must be replaced.

Regulator Internal Resistance

Meter Range	Connections		Reading
	Meter (+) to	Meter (-) to	
x 100 Ω	F	E	170 Ω
x 1 k Ω	E	F	4 k Ω
x 100 Ω	IG	E	800 Ω
x 1 k Ω	E	IG	2 k Ω
x 1 k Ω	F	IG	2 k Ω
x 100 Ω	IG	F	150 Ω

Alternator Troubleshooting:

For any charging system problems, always check the charging system wiring first (see Wiring Inspection), and then check the system with the following tests shown in the troubleshooting guide.

Troubleshooting Guide

Test No.	Trouble	Symptoms
1	Battery discharged	Starter not turning
2	Battery overcharged	Electrolyte level lowering quickly
3	Noise	Alternator noise

Test No.1-Battery Discharged

- Dismount the engine sprocket cover with the clutch slave cylinder mounted.
- Remove the nuts holding the alternator cover, and take off the cover.
- Check that the alternator leads and connectors are in good condition.
- ★ If not, repair or replace the damaged parts.
- Replace the discharged battery with a good battery.
- Check battery voltage with the engine running.
- ★ If the battery voltage is higher than 13.5 V, the charging system is in good condition.
- ★ If the battery voltage is lower than 13.5 V, check the following.
- Ground the F₁ terminal[A] of the regulator to the chassis with a auxiliary wire.
- Start the engine, and check the battery voltage with the engine running.
- ★ If the battery voltage is higher than 13.5 V, check the following.
 - Regulator
- ★ If the battery voltage is lower than 13.5 V, check the following.
 - Carbon brushes, Slip rings
 - Rectifier
 - Starter coil
 - Rotor coil

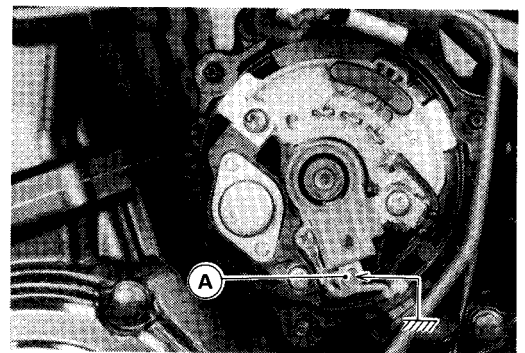

15-22 ELECTRICAL SYSTEM

Test No.2-Battery Overcharged

- Check the regulator and/or rotor
- ★ Repair or replace the damaged parts.

Test No.3-Noise

- Check the ball bearings, stator coil, and/or rectifier if the alternator makes a noise.
- ★ Repair or replace the damaged parts.

Charging system Circuit

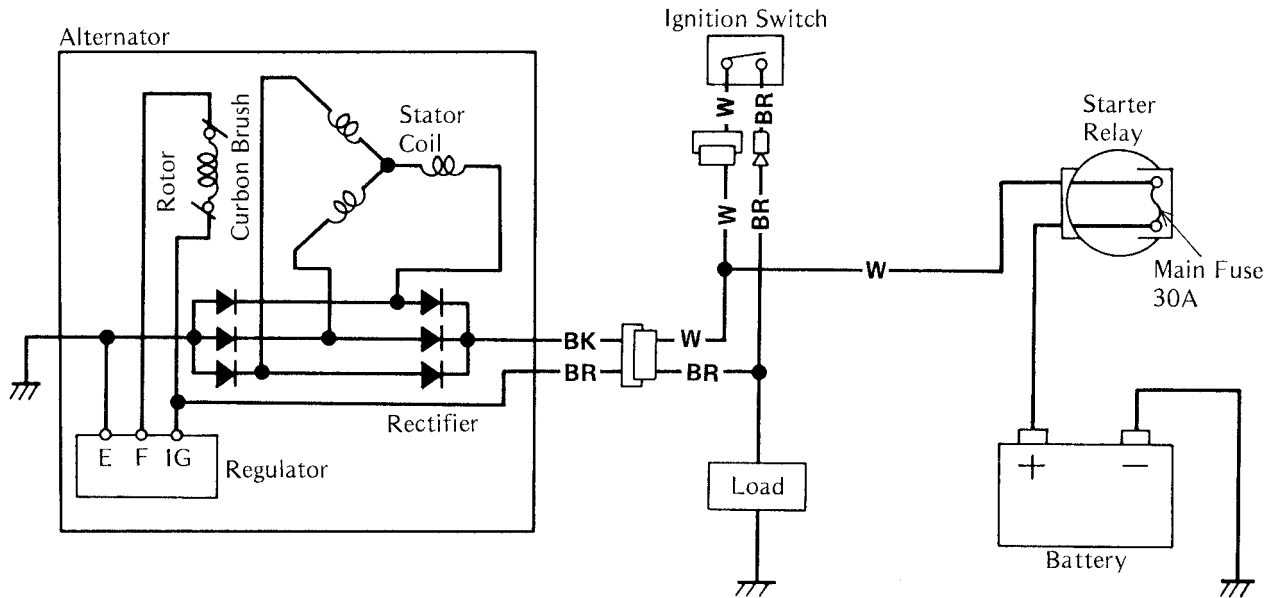

Ignition System

⚠ WARNING

The ignition system produces extremely high voltage. Do not touch the spark plugs, high tension coils, or spark plug leads while the engine is running, or you could receive a severe electrical shock.

CAUTION

Do not disconnect the battery leads or any other electrical connections when the ignition switch is on, or while the engine is running. This is to prevent IC igniter damage.

Do not install the battery backwards. The negative side is grounded. This is to prevent damage to the diodes and IC igniter.

Pickup Coil Removal

- Remove the following.
 - Lower Fairing
 - Pickup Coil Lead Connector
 - Pickup Coil Cover
 - Mounting Bolt (Remove) [B]
 - [A] Pickup Coil

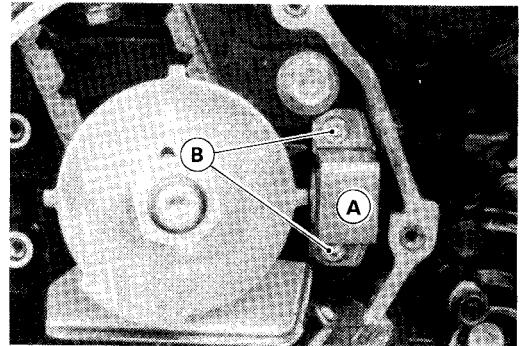

Pickup Coil Installation

- Install the pickup coil [A] so that the air gap (clearance between the timing rotor [B] projection and the pickup coil core) [C] has correct clearance.

Pickup Coil Air Gap [C]
0.7 mm

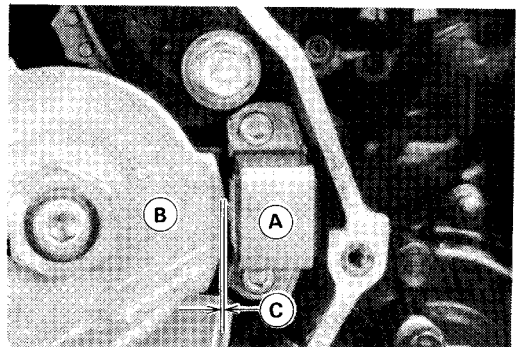

- Be careful of the pickup coil lead tube position.
 - [A] Pickup Coil
 - [B] Position the tube to the pickup coil side.
 - [C] Grommet

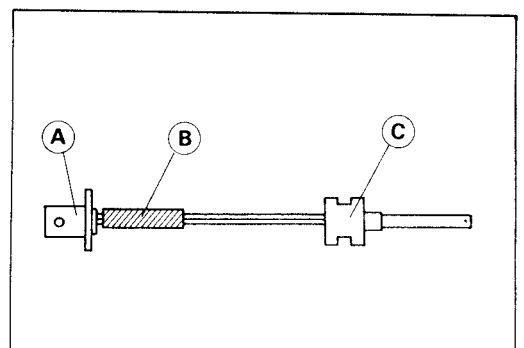

15-24 ELECTRICAL SYSTEM

- Apply a silicone sealant to the following.

[A] Silicone Sealant Applied Area
[B] Crankcase Mating Surface
[C] 5 mm

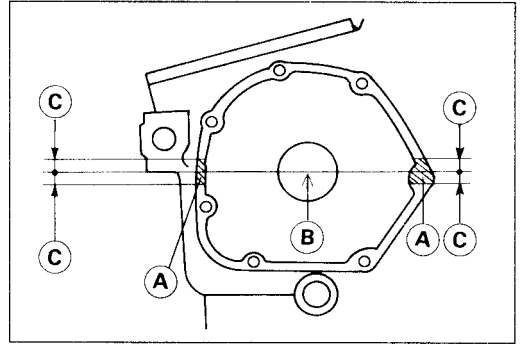

- Apply silicone sealant to the pickup coil grommet.
- Apply a non-permanent locking agent to the two upper left of pickup coil cover bolts [A].

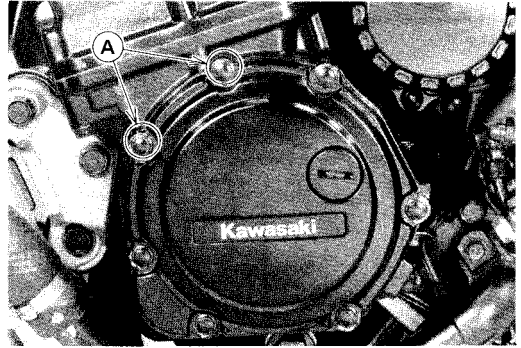

Pickup Coil Inspection

- Set the ohmmeter to the $\times 1 \Omega$ range, and connect it to the pickup coil wires.
- If there is more resistance than the specified value, the coil has an open lead and must be replaced. Much less than this resistance means the coil is shorted, and must be replaced.

Pickup Coil Resistance

380 – 570 Ω

- Using the highest resistance range of the ohmmeter, measure the resistance between the pickup coil leads and chassis ground.
- ★ Any meter reading less than infinity (∞) indicates a short, necessitating replacement of the pickup coil assembly.

Ignition Coil Removal/Installation

- Remove the following
 - Seat
 - Fuel Tank
 - Inner Rear Fairing
 - Air Cleaner Housing
- Disconnect the leads and remove the ignition coils [A].

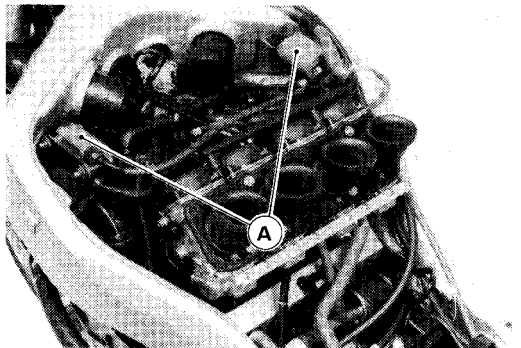

- Install the ignition coil. Note the following.
- Connect the primary winding leads to the ignition coil terminals.
 - Black Lead [A] → to #1, #4 Coil [B]
 - Green Lead [C] → to #2, #3, Coil [D]
 - Red Leads [E] → to both Coils

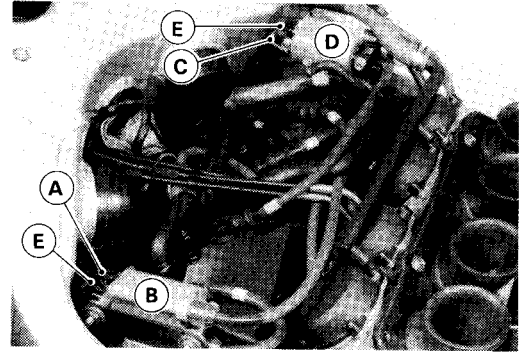

Ignition Coil Inspection

Measuring arcing distance:

The most accurate test for determining the condition of the ignition coil is made by measuring distance.

- Remove the ignition coil.
- Connect the ignition coil (with the spark plug cap left installed on the spark plug lead) to the tester, and measure the arcing distance.

Special Tool – Coil Tester: 57001-1242 [A]

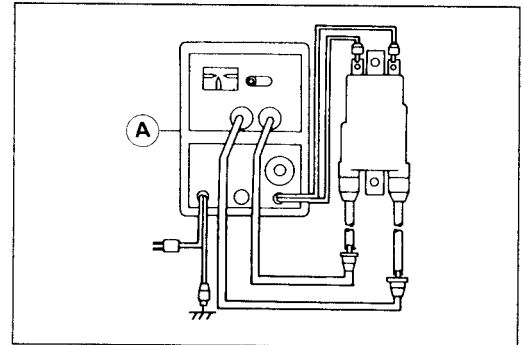

NOTE

- Since a tester other than the Coil Tester may produce a different arcing distance, the Coil Tester is recommended for reliable results.

⚠ WARNING

To avoid extremely high voltage shocks, do not touch the coil or lead.

- ★ If the distance reading is less than the specified value, the ignition coil or spark plug cap is defective.

3 Needle Arcing Distance

Standard: 6 mm or more

- To determine which part is defective, measure the arcing distance again with the spark plug caps removed from the spark plug leads (by turning the caps counterclockwise).
- ★ If the arcing distance is subnormal as before, the trouble is with the ignition coil itself. If the arcing distance is now normal, the trouble is with the spark plug caps.

Measuring coil resistance:

If the Coil Tester is not available, the coil can be checked for a broken or badly shorted winding with a hand tester. However, a hand tester cannot detect layer shorts and shorts resulting from insulation breakdown under high voltage.

- Disconnect the primary leads from the coil terminals.
- Measure the primary winding resistance as follows [A]:
 - Connect the tester between the coil terminals.
 - Set the tester to the $\times 1 \Omega$ range, and read the tester.
- Measure the secondary winding resistance as follows [B]:
 - Remove the plug caps from the spark plug leads.
 - Connect the tester between the spark plug leads.
 - Set the tester to the $\times 1 \text{ k}\Omega$, and read the tester.
- ★ If the hand tester does not read as specified, replace the coil.

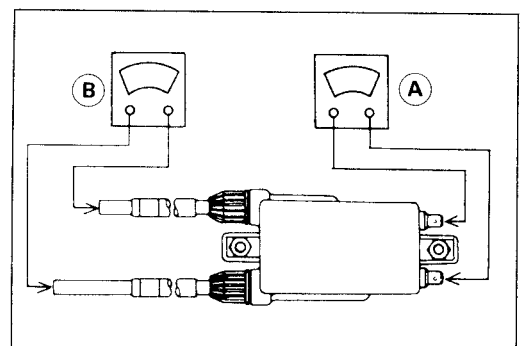

Winding Resistance

Standard: **Primary windings** **2.3 ~ 3.5 Ω**
 Secondary windings **12 ~ 18 k Ω**

- ★ If the tester reads as specified, the ignition coil windings are probably good. However, if the ignition system still does not perform as it should after all other components have been checked, test replace the coil with one known to be good.
- Check the spark plug lead for visible damage.
- ★ If the spark plug lead is damaged, replace the coil.

Spark Plug Removal/Inspection

- Remove:
 - Seat
 - Side Covers
 - Fuel Tank
 - Spark Plug Caps
 - Air Ducts (see the Engine Top chapter)
- Pull the plug caps off the spark plug.
- Unscrew the spark plugs.
Special Tool – Spark Plug Wrench, Hex 16: 57001-1262
- Tighten the spark plug.
Torque – Spark Plug: 14 N-m (1.4 kg-m, 10 ft-lb)

Spark Plug Cleaning and Inspection

- Remove the spark plug, and visually inspect.
- Clean the spark plug, preferably in a sandblasting device, and then clean off any abrasive particles. The plug may also be cleaned using a high flash-point solvent and a wire brush or other suitable tool.
- ★ If the spark plug electrodes are corroded or damaged, or if the insulator is cracked, replace the plug. Use the standard spark plug or its equivalent.

Spark Plug Gap Inspection

- Measure the gap [A] with a wire-type thickness gauge.
- ★ If the gap is incorrect, carefully bend the side electrode [B] with a suitable tool to obtain the correct gap.

Spark Plug Gap

Standard: **0.7 ~ 0.8 mm**

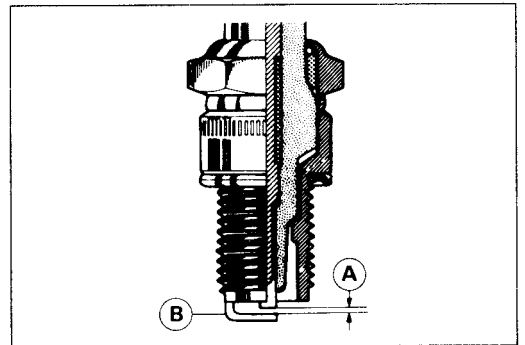

IC Igniter Inspection

CAUTION

When inspecting the IC igniter observe the following to avoid damage to the IC igniter.
Do not disconnect the IC igniter with the ignition switch on. This may damage the IC igniter.
Do not disconnect the battery leads while the engine is running. This may damage the IC igniter.

- Remove the IC igniter.
- Set the hand tester to the $\times 1 \text{ k}\Omega$ range, zero it, and mark the measurements shown in the table.
- ★ If the tester readings are not as specified, replace the IC igniter.

Special Tool – Hand Tester: 57001-983

CAUTION

Use only hand Tester (special tool: 57001 983) for this test. A multi-meter other than the Kawasaki Hand Tester may show different readings.

If a megger or a meter with a large-capacity battery is used, the IC igniter will be damaged.

IC Igniter Internal Resistance (10P)

Unit : $\text{k}\Omega$

Lead	Tester (+) Lead Connection									
	Terminal	R	BK/Y	Y	BK/W	BK	G	G/BK	R/W	BK/R
(-)*	R	-	2.8 ~ 12	4.9 ~ 20	2.8 ~ 12	6.7 ~ 28	6.7 ~ 28	8.5 ~ 34	3.1 ~ 13	8.1 ~ 33
	BK/Y	40 ~ 170	-	1.4 ~ 5.7	0	1.7 ~ 7.2	1.7 ~ 7.2	3.9 ~ 16	0.2 ~ 0.8	2.2 ~ 9.0
	Y	42 ~ 170	1.4 ~ 5.7	-	1.4 ~ 5.7	3.7 ~ 15	3.7 ~ 15	5.2 ~ 21	1.6 ~ 6.4	4.3 ~ 18
	BK/W	40 ~ 170	0	1.4 ~ 5.7	-	1.7 ~ 7.2	1.7 ~ 7.2	3.9 ~ 16	0.2 ~ 0.8	2.2 ~ 9.0
	BK	∞	∞	∞	∞	-	∞	∞	∞	∞
	G	∞	∞	∞	∞	∞	-	∞	∞	∞
	G/BK	46 ~ 190	4.2 ~ 17	5.6 ~ 23	4.2 ~ 17	7.5 ~ 30	7.5 ~ 30	-	8.1 ~ 33	4.4 ~ 18
	R/W	42 ~ 170	0.2 ~ 0.8	1.5 ~ 6.3	0.2 ~ 0.8	2.0 ~ 8.2	2.0 ~ 8.2	4.0 ~ 17	-	2.5 ~ 10
	BK/R	70 ~ 280	30 ~ 120	30 ~ 130	30 ~ 120	42 ~ 170	42 ~ 170	34 ~ 140	30 ~ 120	-

(-)*: Tester (-) Lead Connection

15-28 ELECTRICAL SYSTEM

Ignition System Troubleshooting

NOTE

- It is understood that the battery is charged fully and that the ignition switch, wirings, and connectors have no problem.

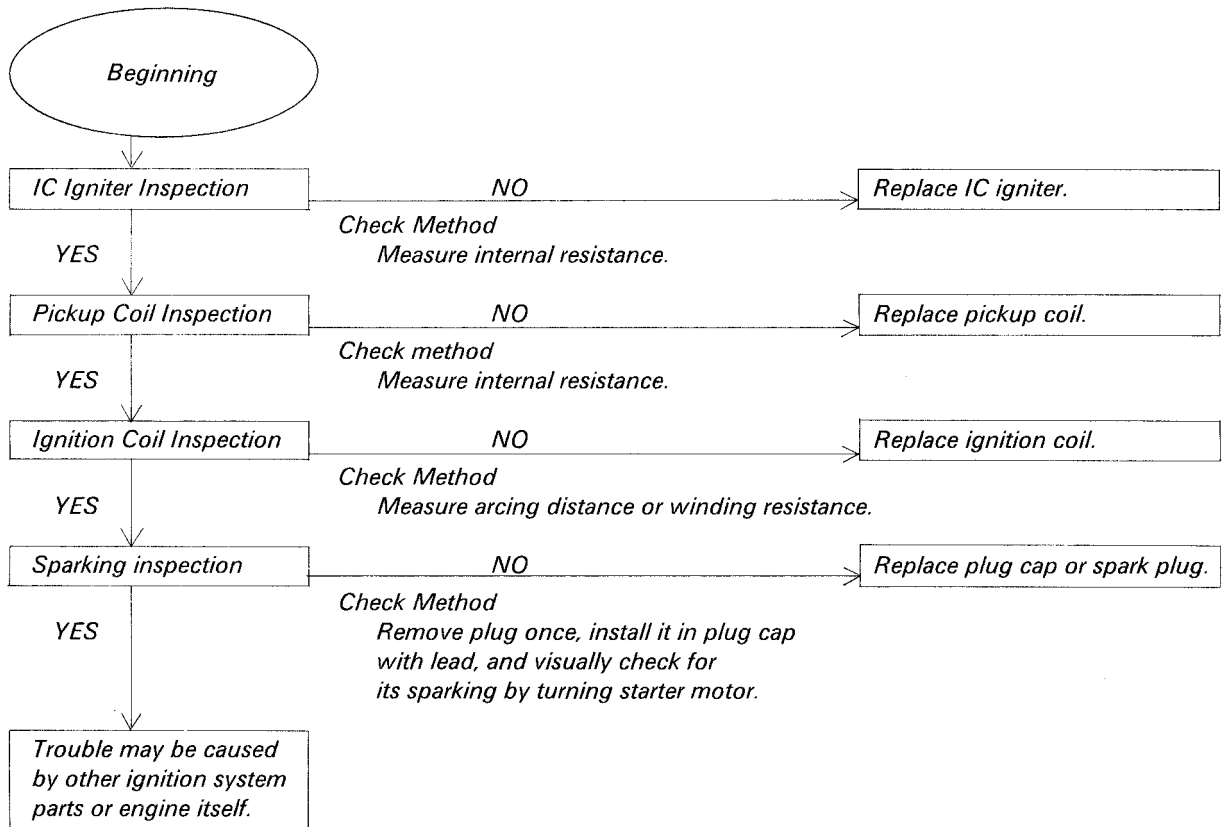

Ignition System Circuit

- | | | |
|--|--|-----------------------|
| 1. IC Igniter | 8. Ignition Coil (for #2, #3 cylinder) | 15. Main Fuse 30A |
| 2. 6-Pin Connector | 9. Spark Plugs | 16. Diodes |
| 3. 4-Pin Connector | 10. 10-Pin Connector | 17. Battery |
| 4. Pickup Coil | 11. 9-Pin Connector | 18. Side Stand Switch |
| 5. Junction Box | 12. Starter Lockout Switch | 19. Starter Relay |
| 6. Timing Rotor | 13. Ignition Switch | 20. 2-Pin Connector |
| 7. Ignition Coil (for #1, #4 cylinder) | 14. Engine Stop Switch | 21. Neutral Switch |

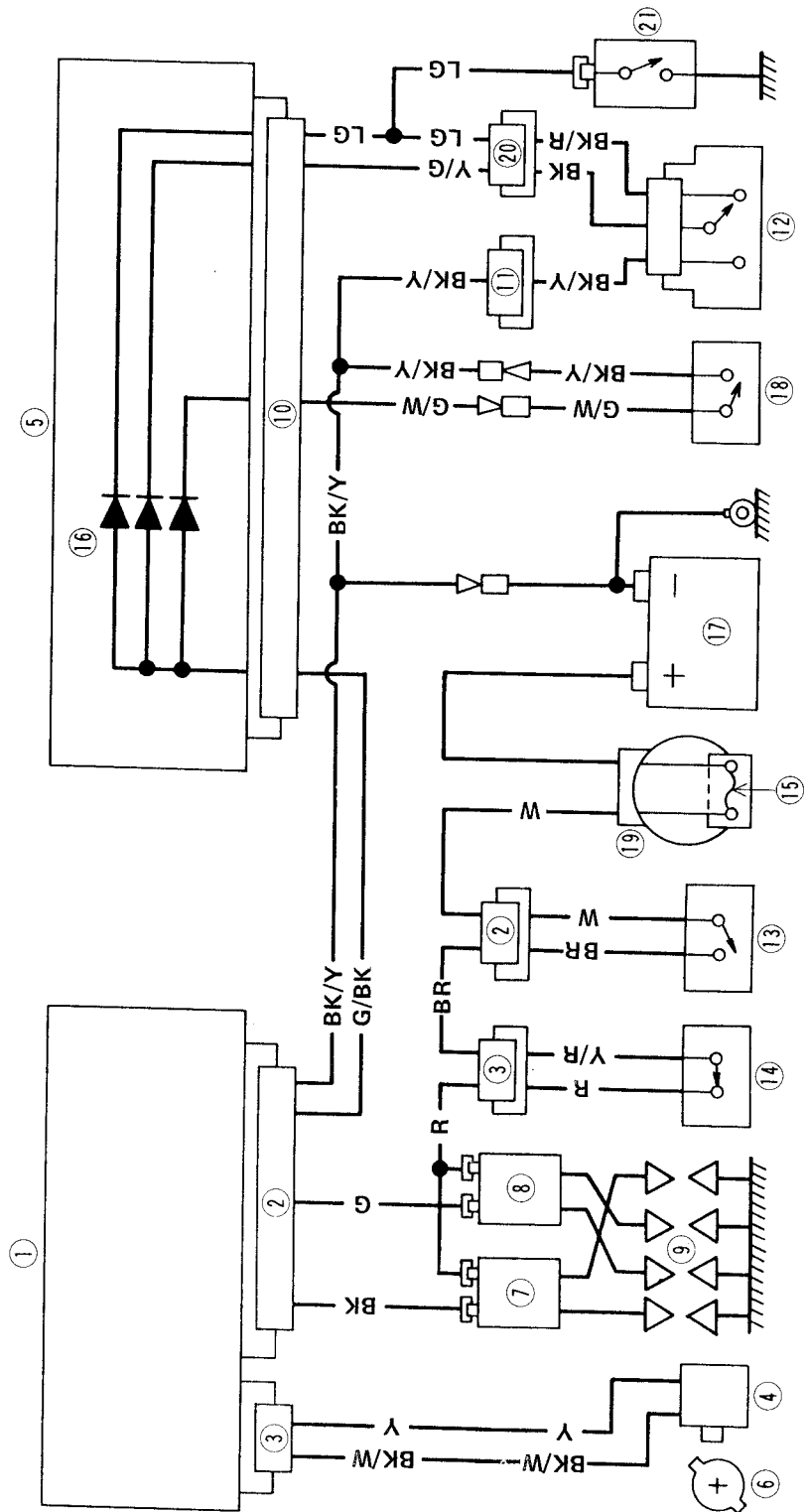

15-30 ELECTRICAL SYSTEM

Electric Starter System

Starter Motor Removal

- Remove the engine (see Engine Removal/Installation chapter).
- Remove the following.
 - Engine Oil (Drain)
 - External Shift Mechanism Cover
 - Starter Motor Cable
- Remove the starter motor mounting bolts and pull out the starter motor.

CAUTION

Do not tap the starter motor shaft or body. Tapping on the shaft or body could damage the motor.

Starter Motor Installation

- Installation is the reverse of removal. Note the following.
- Clean the starter motor legs and crankcase where the starter motor is grounded [A].

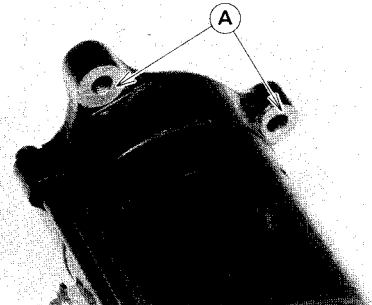
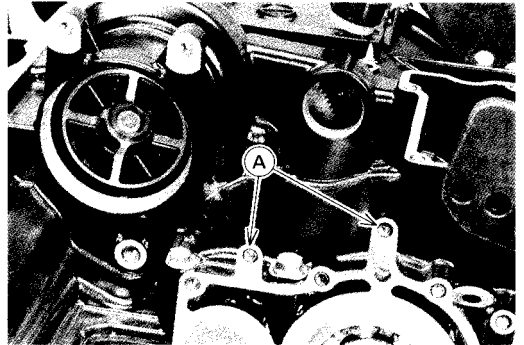

- Apply a small amount of engine oil to the O-ring [A].

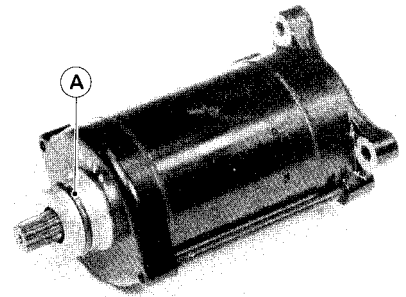

Disassembly

- Remove both end covers [A] and pull the armature out of the yoke.
[B] Bolts

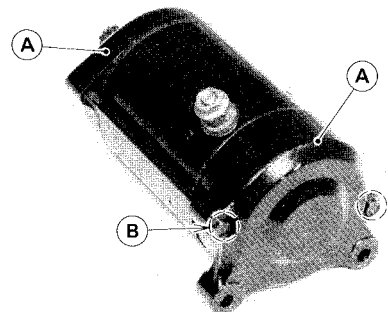

- Remove the brush plate [A].

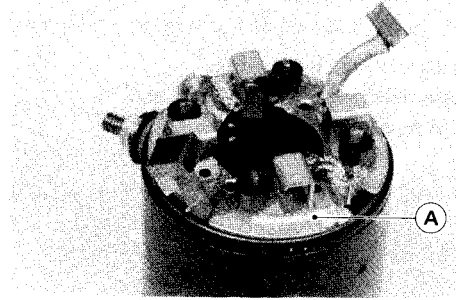

- Remove the nut and remove the terminal bolt, and then remove the brush with the plastic holder.

- [A] Nut
- [B] Washer
- [C] Large Washer (Plastic)
- [D] Small Washer (Plastic)
- [E] Terminal Bolt
- [F] Plastic Holder

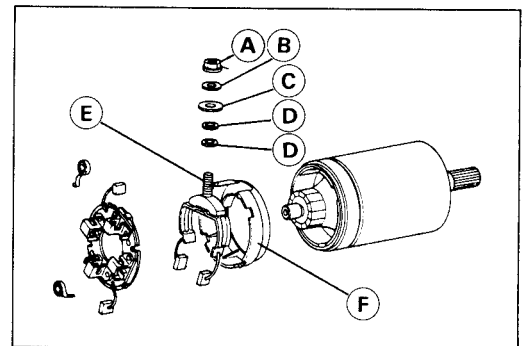

Assembly

- Assembly is the reverse of removal. Note the following.
- Apply a thin coat of grease to the oil seal [B].
- Fit the toothed washer [A] to the end cover.

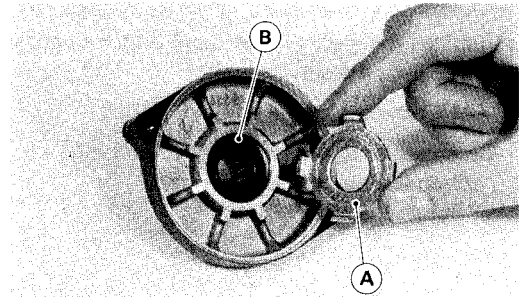

- Fit the tongue [A] on the brush plate into the end cover groove [B].

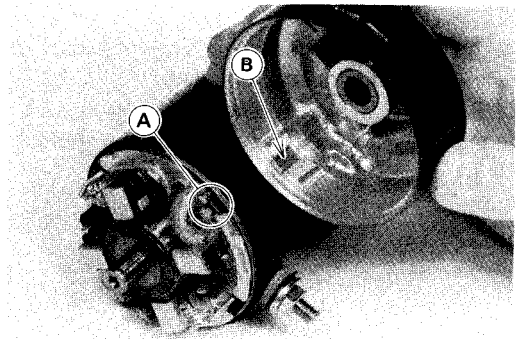

- Align the mark [A] on the end cover with the terminal bolts [B].

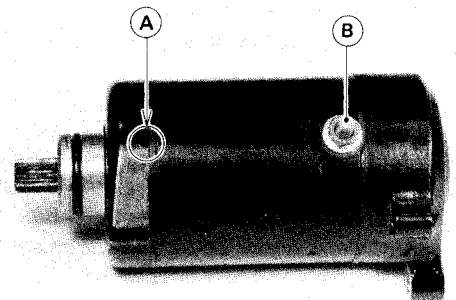

Brush Inspection

- Measure the length of each brush.
- ★ If any is worn down to the service limit, replace all brushes.

Starter Motor Brush Length

Standard:	12.0 ~ 12.5 mm
Service Limit:	6 mm

Commutator Cleaning and Inspection

- Smooth the commutator surface [A] if necessary with fine emery cloth [B], and clean out the grooves as illustrated.

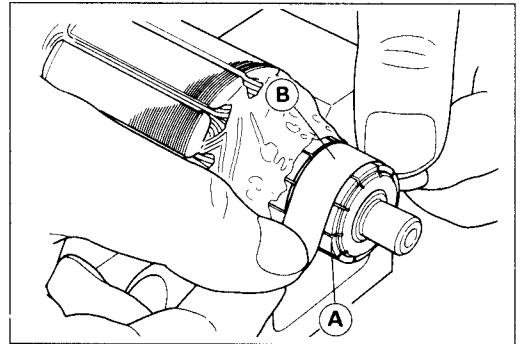

- Measure the diameter of the commutator [B].
- ★ Replace the starter motor with a new one if the commutator diameter is less than the service limit.

[A] Commutator Segment [C] Shaft

Commutator Diameter

Standard:	28 mm
Service Limit:	27 mm

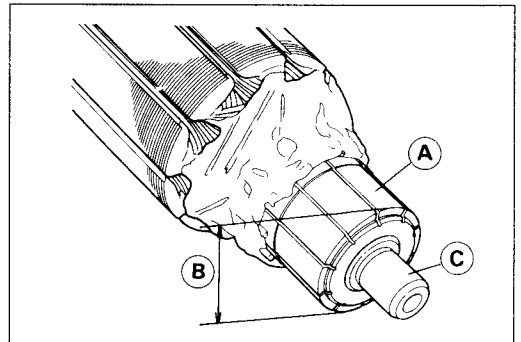

Armature Inspection

- Using the $\times 1 \Omega$ ohmmeter range, measure the resistance between any two commutator segments [A].
- ★ If there is a high resistance or no reading (∞) between any two segments, a winding is open and the starter motor must be replaced.

[B] Shaft

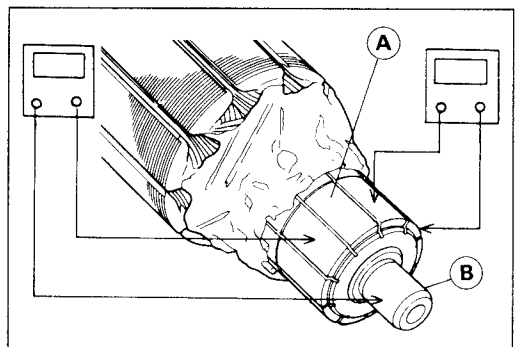

- Using the highest ohmmeter range, measure the resistance between the commutator and the shaft.
- ★ If there is any reading at all, the armature has a short and the starter motor must be replaced.

NOTE

○ Even if the foregoing checks show the armature to be good, it may be directive in some megger not readily detectable with an ohmmeter. If all other starter motor and starter motor circuit components check good, but the starter motor still does not turn over or only turns over weakly, replace the starter motor with a new one.

Negative Brush and Lead Assembly Inspection

- Using the $\times 1 \Omega$ ohmmeter range, measure the resistance as follows.
- Between the brush and brush plate.
- Between the brush holder and brush plate.

Brush Plate Inspection

- Measure the resistance as follows.

	Meter Range	Connections	Meter Reading
A	$\times 1 \text{ k}\Omega$	Terminal Bolt \rightarrow Brush Plate	∞
B	$\times 1 \Omega$	Terminal Bolt \rightarrow Positive Brush	0Ω
C	$\times 1 \text{ k}\Omega$	Positive Brush \rightarrow Negative Brush	∞

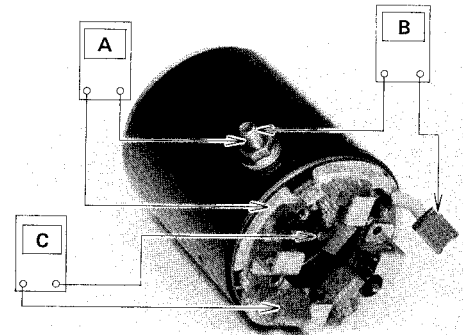

- ★ If the meter does not read as specified, check the terminal bolt insulations.
- ★ If the terminal bolt insulations are not defective, replace the brush plate.

Starter Relay Inspection

- Remove the starter relay.
- Connect the ohmmeter [A] and 12 V battery [B] to the starter relay as shown.
- ★ If the relay does not work as specified, the relay is defective. Replace the relay.

Testing Relay

Meter Range $\times 1 \Omega$ range
Criteria When battery is connected $\rightarrow 0 \Omega$
 When battery is disconnected $\rightarrow \infty$

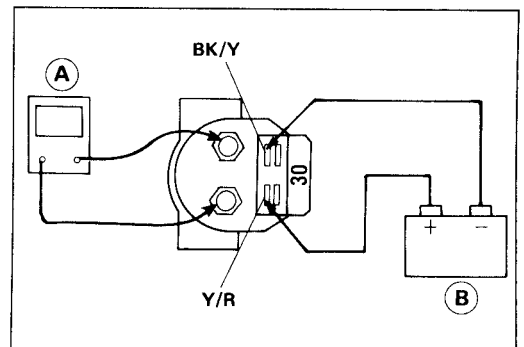

Electric Starter System Circuit

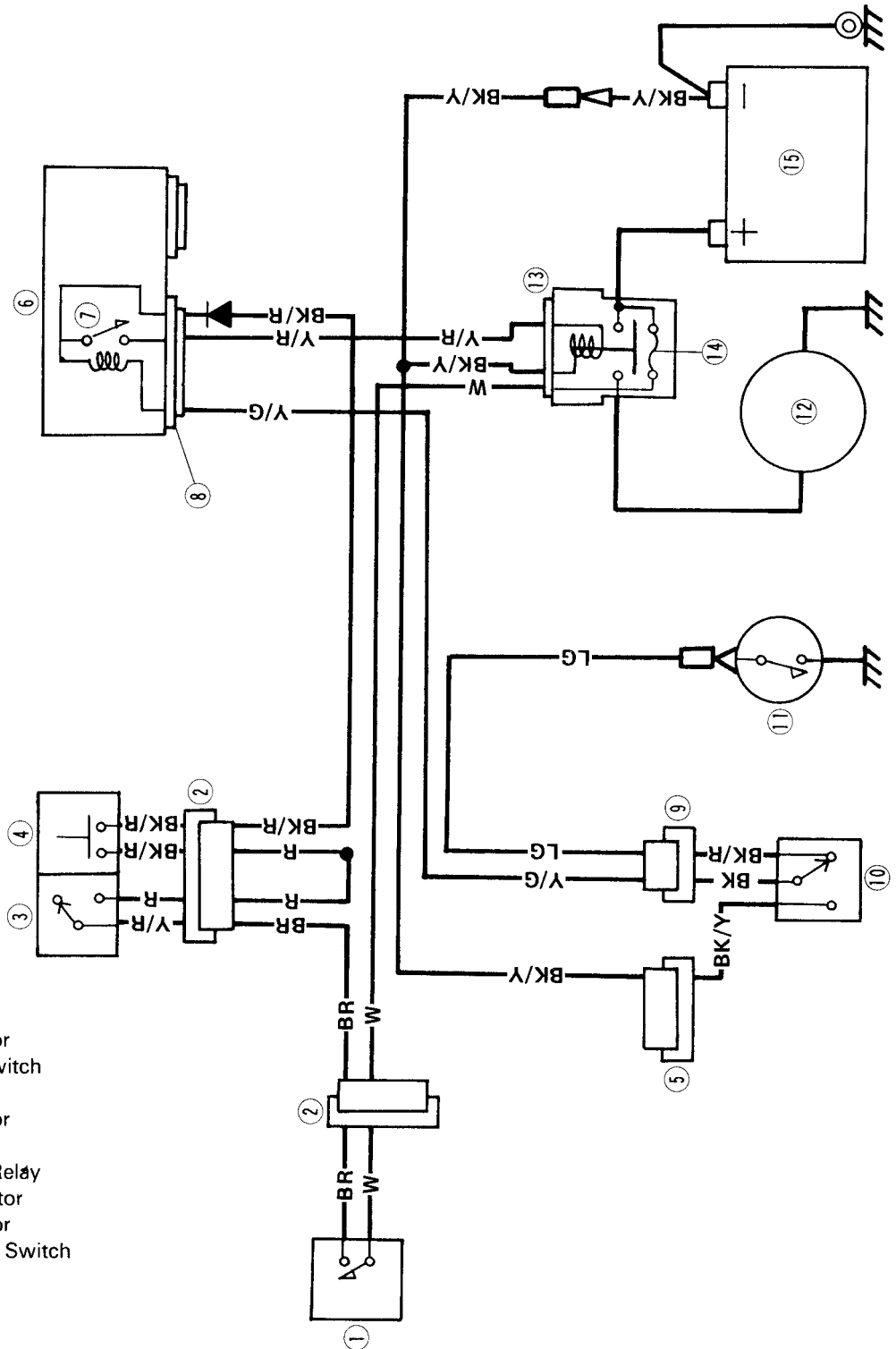

- 1. Ignition Switch
- 2. 6-pin Connector
- 3. Engine Stop Switch
- 4. Starter Button
- 5. 9-pin Connector
- 6. Junction Box
- 7. Starter Circuit Relay
- 8. 10-pin Connector
- 9. 2-pin Connector
- 10. Starter Lockout Switch
- 11. Neutral Switch
- 12. Starter Motor
- 13. Starter Relay
- 14. Main Fuse 30 A
- 15. Battery

Headlight

Headlight Beam Horizontal Adjustment

The headlight beam is adjustable horizontally. If not properly adjusted horizontally, the beam will point to one side rather than straight ahead.

- [A] Horizontal Adjuster
- [B] Vertical Adjuster

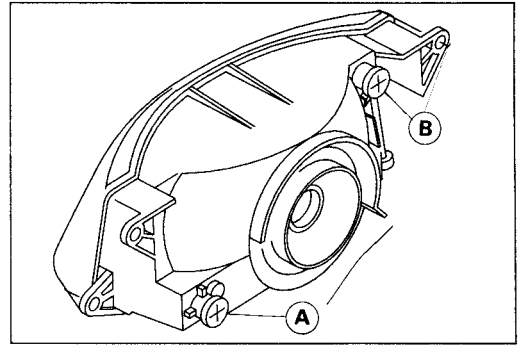

- Take the screw [B] off the plate [A] located under the headlight and pull it to the rear.

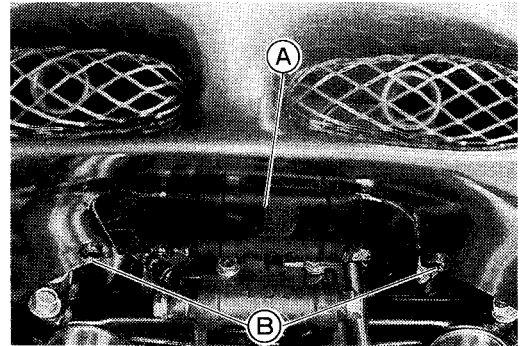

- Turn the horizontal adjuster [A] in or out until the beam points straight ahead.

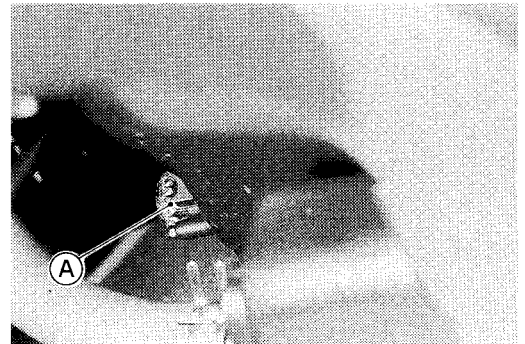

Headlight Beam Vertical Adjustment

The headlight beam is adjustable vertically. If adjusted too low, neither low nor high beam will illuminate the road far enough ahead. If adjusted too high, the high beam will fail to illuminate the road close ahead, and the low beam will blind oncoming drivers.

- Turn the vertical adjuster [A] in or out to adjust the headlight vertically.
- Reinstall the plate.

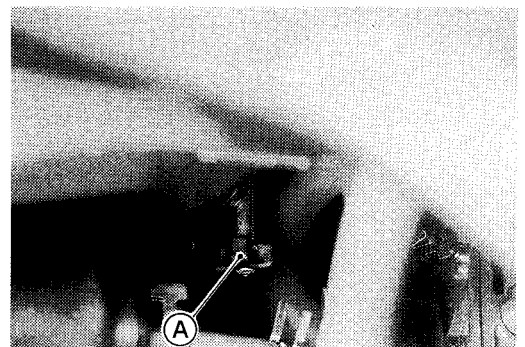

NOTE

- On high beam, the brightest point should be slightly below horizontal with the motorcycle on its wheels and the rider seated. Adjust the headlight to the proper angle according to local regulations.

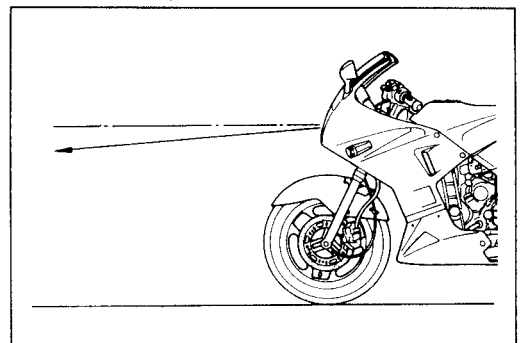

Headlight Bulb Replacement Notes

CAUTION

When handling the quartz-halogen bulbs, never touch the glass portion with bare hands. Always use a clean cloth. Oil contamination from hands or dirty tags can reduce bulb life or cause the bulb to explode.

- Fit the dust cover [A] onto the bulb [B] firmly as shown in the figure.
- After installation, adjust the headlight aim.

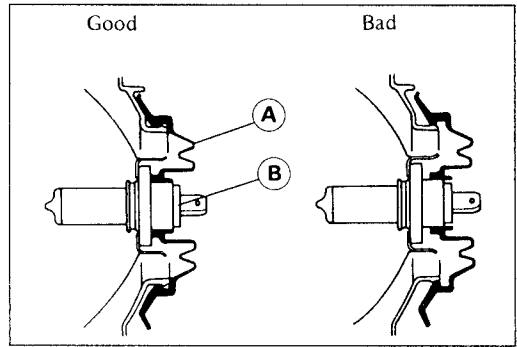

Headlight Circuit Inspection

The US, Canadian and Australian models contain a relay in the headlight circuit. In these models, the headlight does not go on when the ignition switch is first turned on, but the headlight goes on once the starter button is pushed to start the engine, and stays on until the ignition switch is turned off. But the headlight goes out whenever the starter button is pushed to restart the engine after engine stalling.

Headlight Circuit (Other than U.S., Canada and Australia)

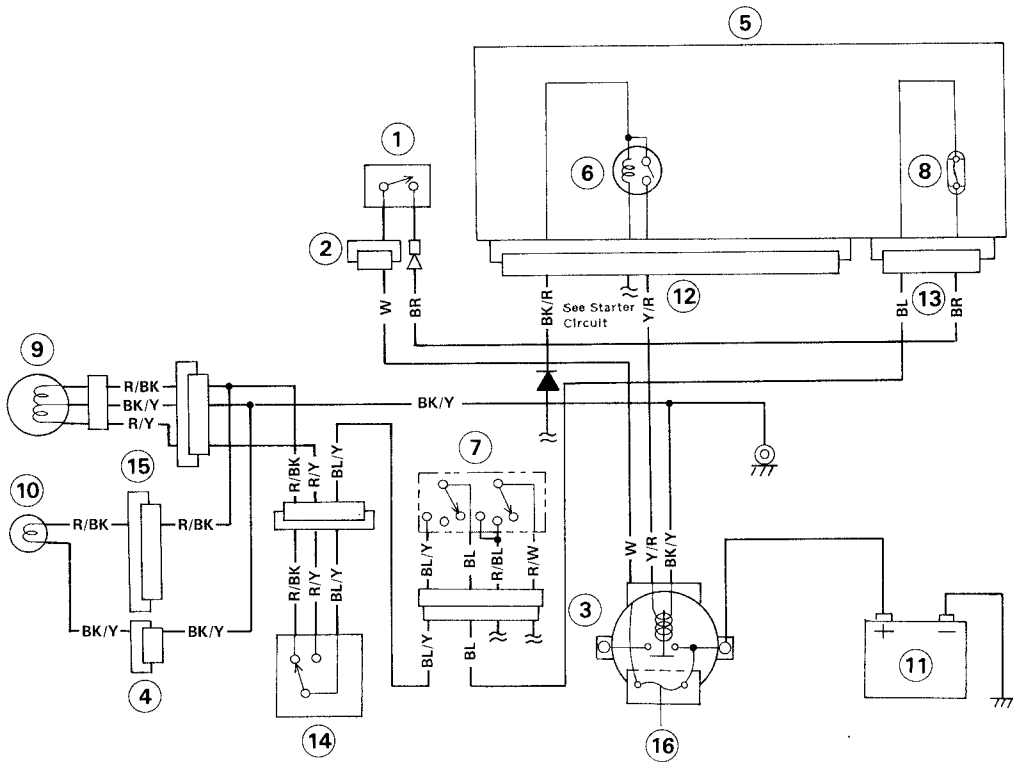

- | | | |
|--------------------------|-------------------------------|---------------------|
| 1. Ignition Switch | 7. Lighting Switch | 13. 8-pin Connector |
| 2. 6-pin Connector | 8. Headlight Fuse 10A | 14. Dimmer Switch |
| 3. Starter Relay | 9. Headlight | 15. 9-pin Connector |
| 4. 4-pin Connector | 10. High Beam Indicator Light | 16. Main Fuse 30A |
| 5. Junction Box | 11. Battery | |
| 6. Starter Circuit Relay | 12. 10-pin Connector | |

Headlight Circuit (US, Canada and Australia)

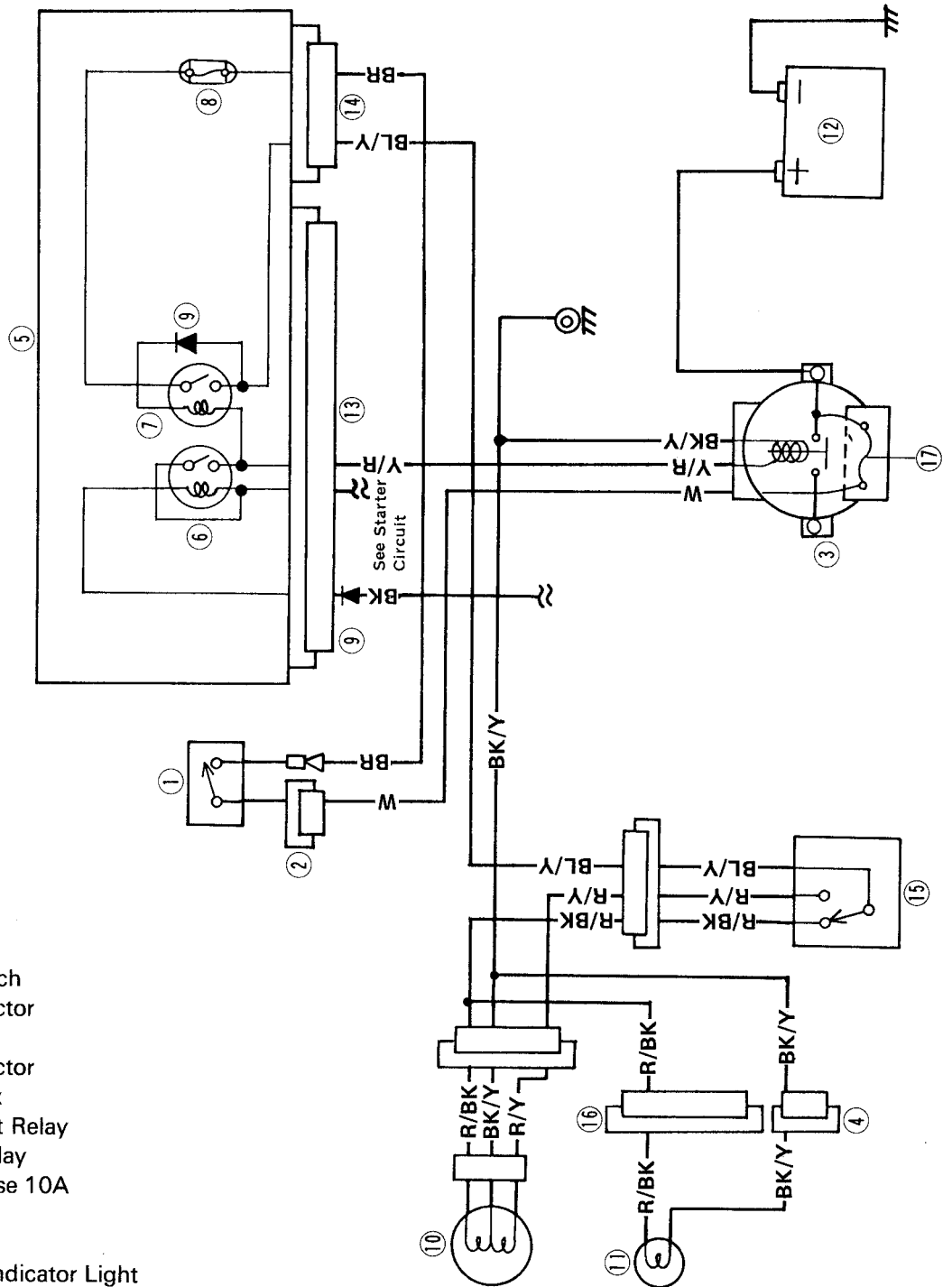

1. Ignition Switch
2. 6-pin Connector
3. Starter Relay
4. 4-pin Connector
5. Junction Box
6. Starter Circuit Relay
7. Headlight Relay
8. Headlight Fuse 10A
9. Diode
10. Headlight
11. High Beam Indicator Light
12. Battery
13. 10-pin Connector
14. 8-pin Connector
15. Dimmer Switch
16. 9-pin Connector
17. Main Fuse 30A

15-38 ELECTRICAL SYSTEM

Fuel Pump

The pump operates when the starter button is pushed on or the engine is running.

When fuel level in the float chamber is low, the fuel pump operates to supply fuel into the float chamber.

When the fuel reaches a certain level, the fuel pressure rises, and fuel pump stop.

Fuel Pump Relay Internal Resistance

● Set the ohmmeter to the $\times 1\text{ k}\Omega$ range and make the measurements shown in the table.

★ If the meter readings are not as specified, replace the fuel pump relay.

CAUTION

Use only Hand Tester 57001-983 for this test. An ohmmeter other than the Kawasaki Hand Tester may show different readings. If a megger or a meter with a large-capacity battery is used, the pump relay will be damaged.

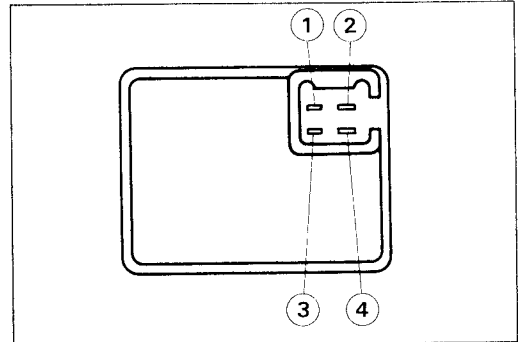

Fuel Pump Relay Internal Resistance ($\times 1\text{ k}\Omega$)

Tester (-) Lead Connection	Tester (+) Lead Connection			
	1	2	3	4
1	-	∞	∞	∞
2	∞	-	∞	∞
3	∞	10~100	-	∞
4	∞	20~200	1 ~ 5	-

Check for Proper Operation

- Remove the fuel pump with fuel filter.
- Prepare a container filled with kerosene.
- Prepare the rubber hoses, and connect them to the pump fittings.
- Connect the suitable pressure gauge to the outlet hose as shown.

- | | |
|--------------------|---------------------|
| [A] Fuel Pump | [E] Fuel Filter |
| [B] Pressure Gauge | [F] Kerosene |
| [C] Outlet Hose | [G] 4-pin Connector |
| [D] Inlet Hose | [H] Battery |

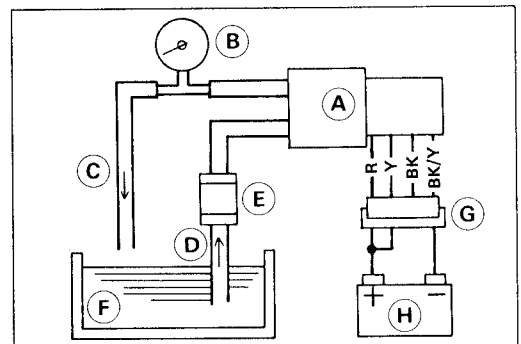

- Prepare the 4-pin connector with wires, and connect it into the pump wire connector.
- Connect the battery + wire to the Red and Yellow wires, then battery - wire to the Black/Yellow wire at the pump connector.
- ★ If the pump does not operate, the pump is defective.
- Close the outlet hose while operating the fuel pump.
- When the pump is stopped, read the pressure gauge.
- If the pressure gauge reading out of the specified pressure, the pump is defective.

Fuel Pump Pressure

Standard: 11 - 16 kPa
(0.11 - 0.16 kg/cm², 1.6 - 2.3 psi)

Fuel Pump Circuit

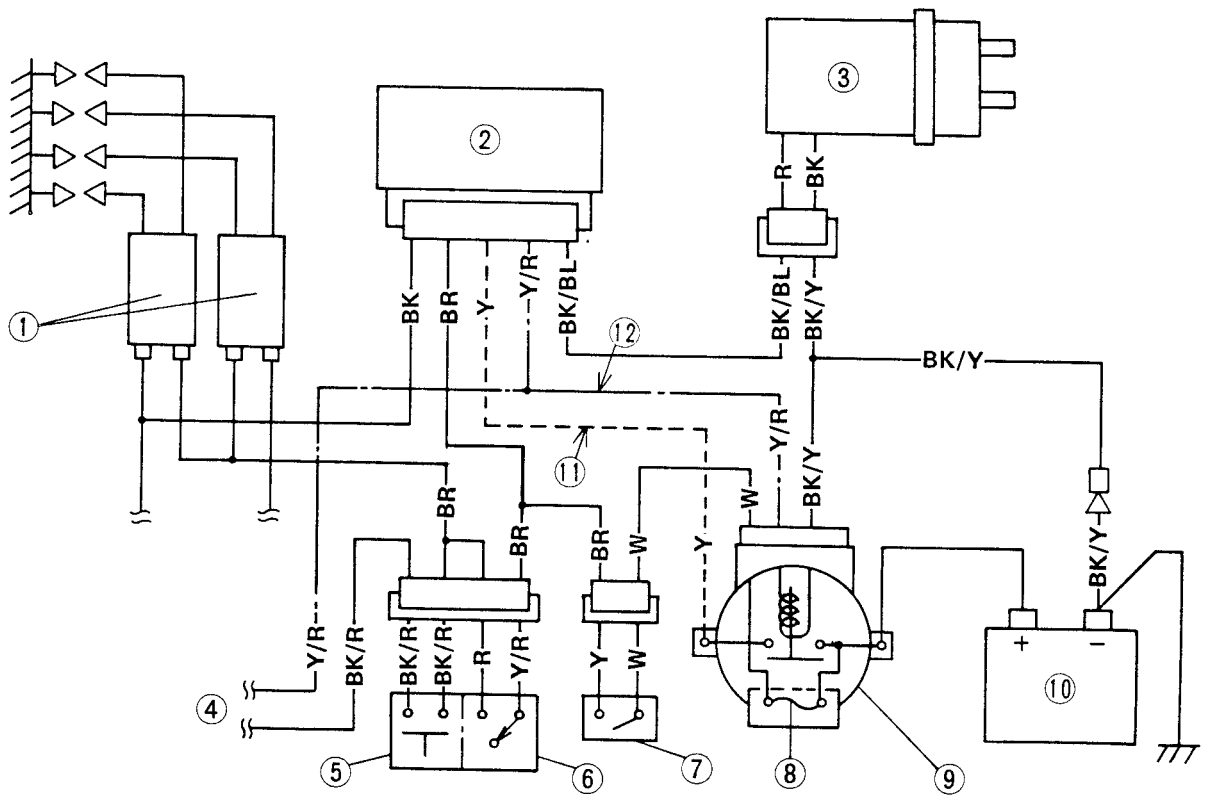

- 1. Ignition Coils
- 2. Fuel Pump Relay
- 3. Fuel Pump
- 4. Starter Circuit

- 5. Starter Bottom
- 6. Engine Stop Switch
- 7. Ignition Switch
- 8. Main Fuse, 30A

- 9. Starter Relay
- 10. Battery
- 11. For US, Canada and Australia Models
- 12. For Other than US, Canada and Australia Models

15-40 ELECTRICAL SYSTEM

Cooling Fan System

Fan System Circuit Inspection

- Disconnect the cooling fan switch leads [A] from the cooling fan switch.
- Using an auxiliary wire, connect the cooling fan switch leads.
- ★ If the fan turns, inspect the following.
 - Switches (Fan Switch)
- ★ If the fan does not turn, inspect the following.
 - Wires and Connectors
 - Junction Box Parts (Fan Relay and Fan Fuse)
 - Main Fuse
 - Fan

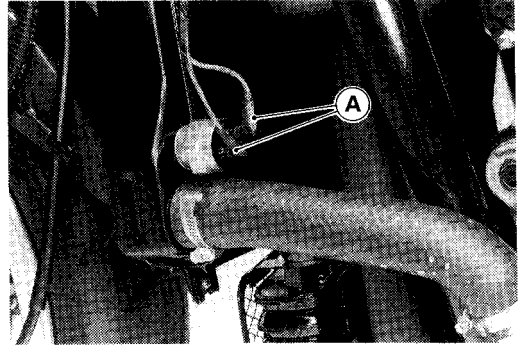

Fan Inspection

- Disconnect the 2-pin connector in the fan leads.
 - Using two auxiliary wires, supply battery power to the fan.
 - ★ If the fan does not turn at this time, the fan is defective and must be replaced.
- | | |
|-----------------|--------------------|
| 1. Junction Box | 5. Starter Relay |
| 2. Fan Fuse 10A | 6. Main Fuse 30A |
| 3. Cooling Fan | 7. Battery |
| 4. Fan Switch | 8. 8-pin Connector |

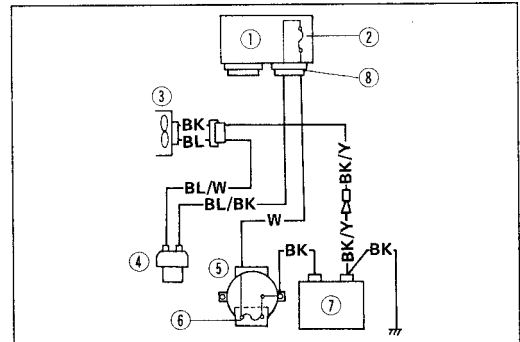

Fan Switch Inspection

- Using an ohmmeter measure the internal resistance of the fan switch [A] across the removal and the body at the temperatures shown in the table.
- ★ If the ohmmeter does not show the specified values, replace the sensor.

Fan Switch Connections

- | | |
|------------------------|--|
| ○ Rising temperature: | From OFF to ON
at 93 – 103°C (199 – 217°F) |
| ○ Falling temperature: | From ON to OFF
at 91 – 95°C (196 – 203°F) |

ON : Less than 0.5 Ω
OFF : More than 1MΩ

- Suspend the switch in a container of coolant so that the temperature-sensing projection and threaded portion are submerged.
- Suspend an accurate thermometer in the water.

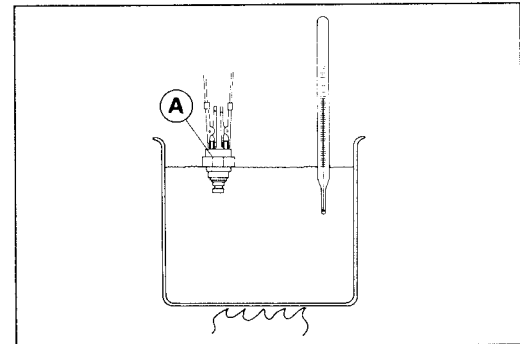

NOTE

- The switch and thermometer must not touch the container sides or bottom.
- Place the container over a source of heat and gradually raise the temperature of the water while stirring the water gently.

Meters, Gauge

Meter Removal

- Remove the following.
 - Upper Fairing
 - Meter Mounting Bolts [A]
 - Speedometer Cable (from Meter) [B]
 - Meter Lead Connector (disconnect) [C]

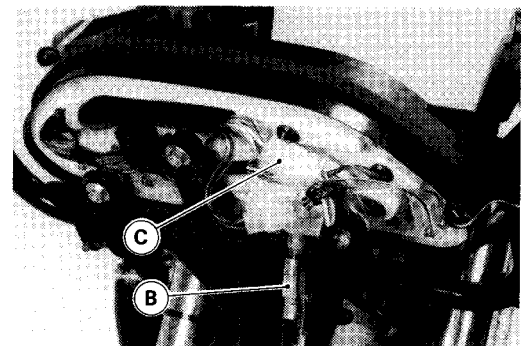
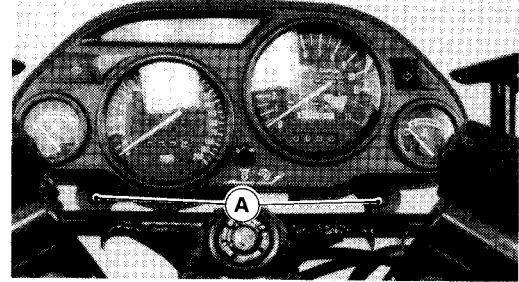

CAUTION

Place the meter so that the face is up. If a meter is left upside down or sideways for any length of time, it will malfunction.

Tachometer Inspection

- Check the tachometer circuit wiring.
- ★ If all wiring, main fuse, ignition coil check out good, the unit is defective.

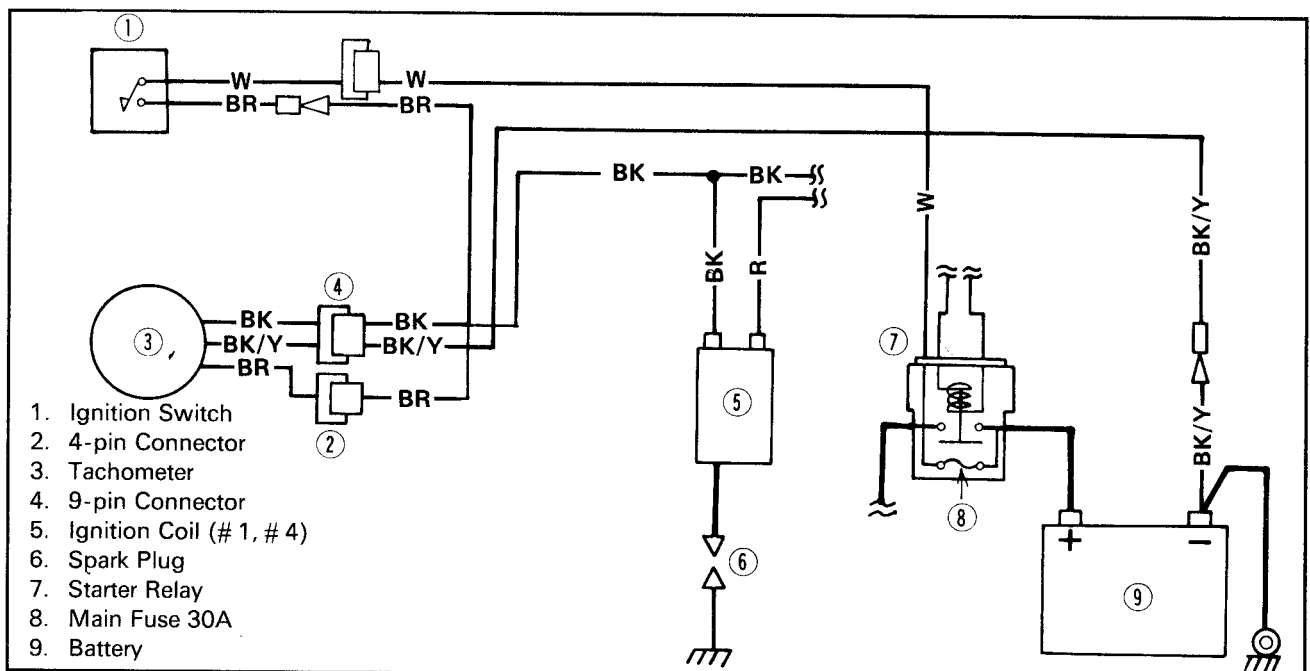

Fuel Level Sensor Inspection

- Remove the fuel tank (see Fuel System chapter).
- Remove the fuel level sensor from the fuel tank.
- Check that the float moves up and down smoothly without binding. It should go down under its own weight.
- ★ If the float does not move smoothly, replace the sensor.

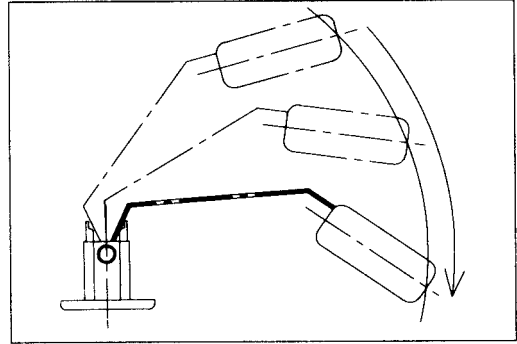

- Using a hand tester, measure the resistance across the terminals in the fuel level sensor lead connector [A].
- ★ If the tester reading are not as specified, or do not change smoothly according as the float moves up and down, replace the sensor.

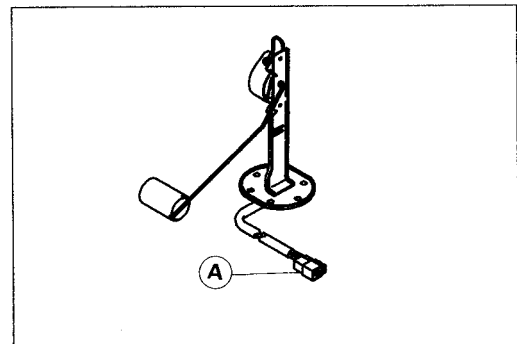

Fuel Level Sensor Resistance

Standard	Full position:	4 ~ 10 Ω
	Empty position:	90 ~ 100 Ω

Special Tool – Hand Tester: 57001-983

Fuel Level Sensor Operation circuit

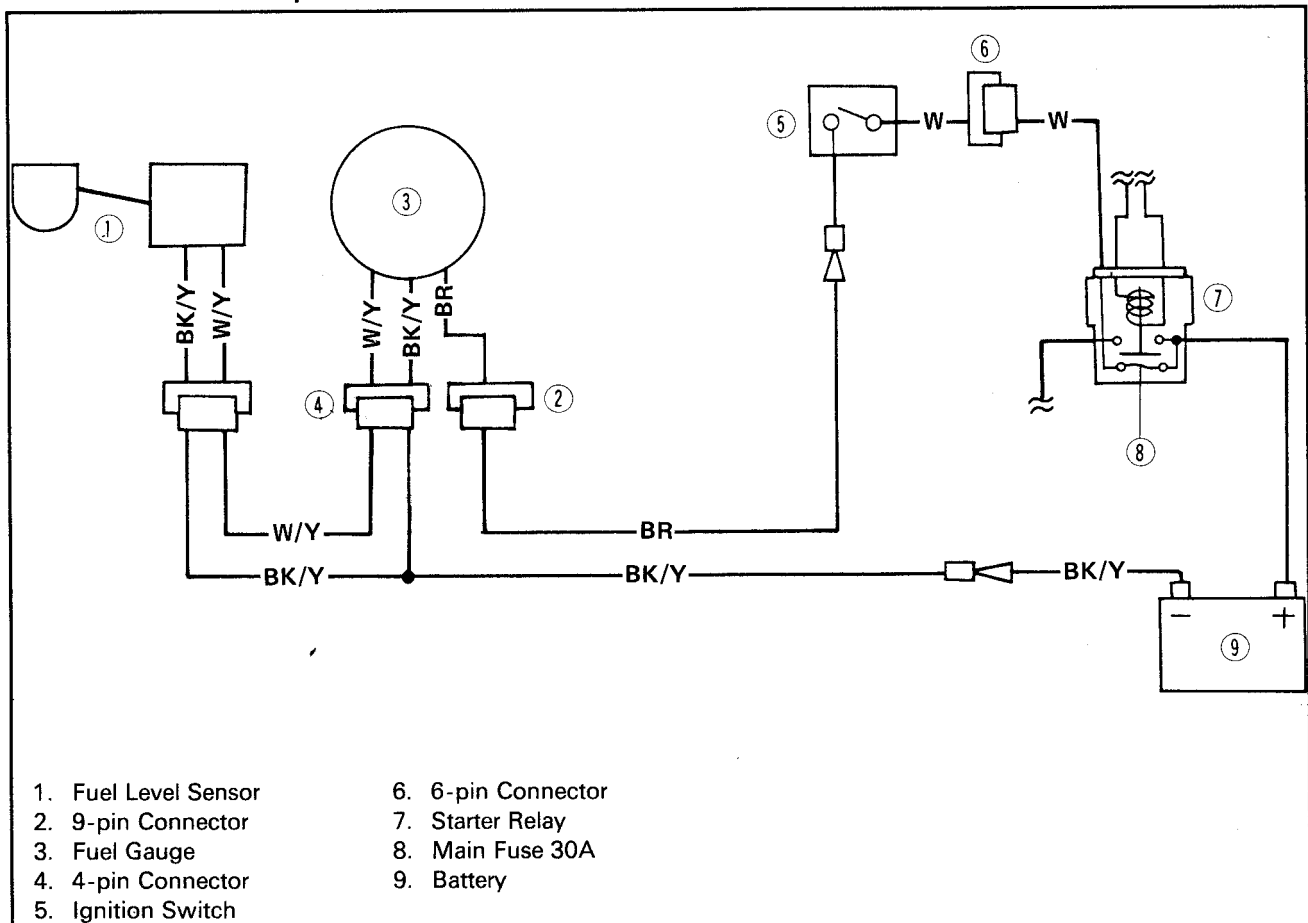

Water Temperature Gauge Operation Inspection

- Prepare an auxiliary wire, and check the operation of the gauge.

Gauge Operation Test

Ignition Switch Position: ON

**Wire Location: Female, Sensor Connector
(disconnected)**

**Results: Gauge should read C when sensor wire is opened.
Gauge should read H when connector wire is grounded to engine.**

CAUTION

Do not ground the wiring longer than necessary. After the needle swings to the H position, stop the test. Otherwise the gauge could be damaged.

- ★ If there readings are nor correct, the trouble is with the gauge and/or wiring.
- Check the water temperature gauge circuit wiring (see Wiring Inspection).
- If all wiring and components other than the water temperature gauge unit check out good, the gauge is defective.

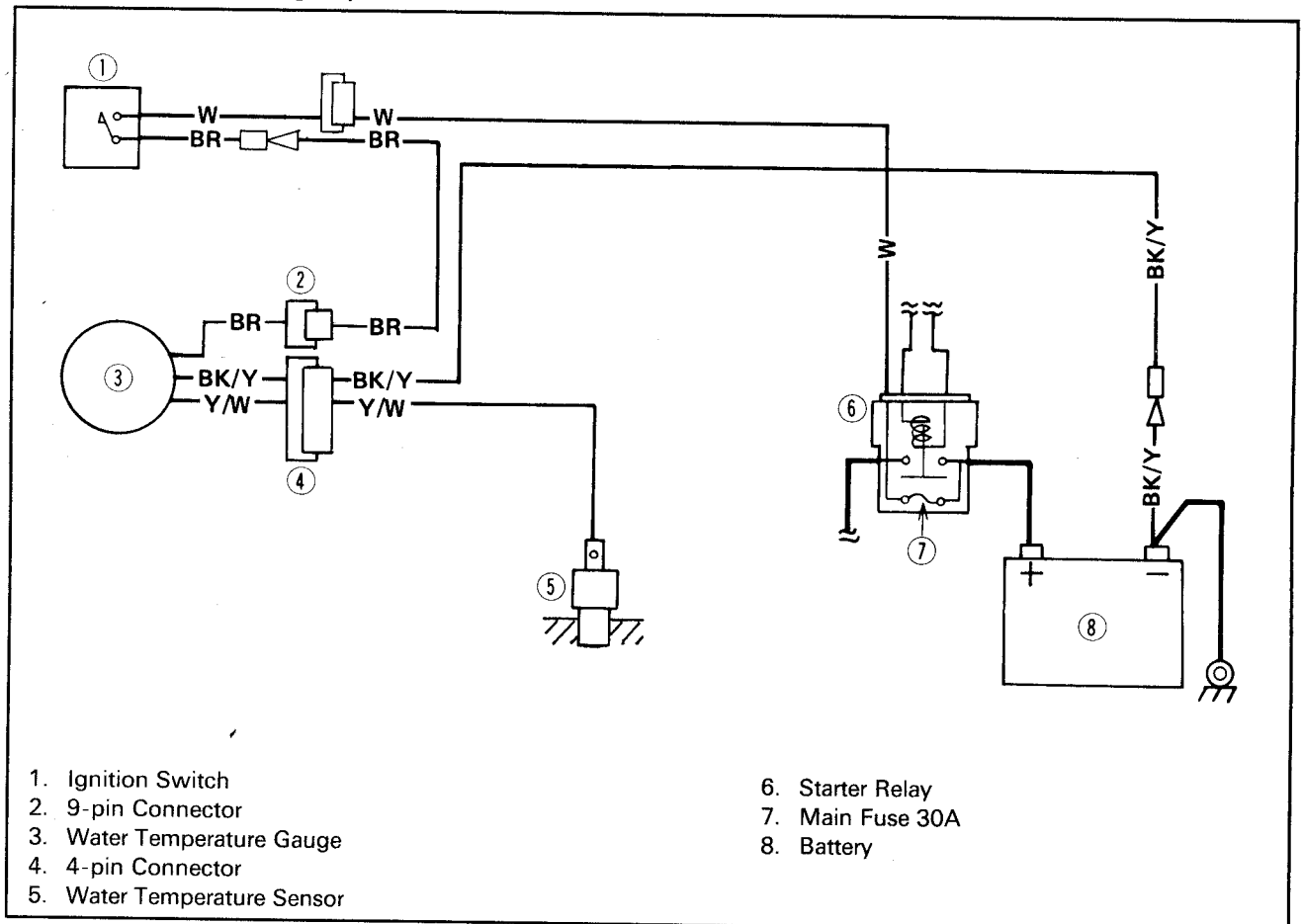
Water Temperature Gauge Operation Circuit

1. Ignition Switch
2. 9-pin Connector
3. Water Temperature Gauge
4. 4-pin Connector
5. Water Temperature Sensor

6. Starter Relay
7. Main Fuse 30A
8. Battery

Water Temperature Sensor Inspection

- Suspend the sensor in a container of water so that the temperature sensing projection and threaded portion are submerged.
- Using an ohmmeter, measure the internal resistance of the sensor [A] across the terminal and the body at the temperatures shown in the table.

NOTE

- *The sensor and thermostat [B] must not touch the container sides or bottom.*

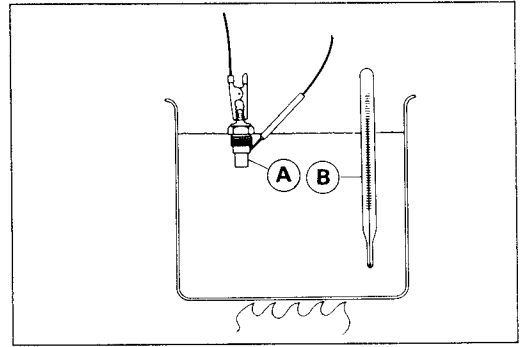

- ★ If the ohmmeter does not show the specified values, replace the sensor.

Water Temperature resistance

80°C (176 °F) : about 52 Ω

100°C (212°F) : about 27 Ω

Junction Box

The junction box has fuses, relays and diodes. The relays and diodes can not be removed.

Fuse Removal

- Remove the seat, and pull out the junction box [A].
- Unhook, and remove the fuse cover [B] from the junction box.
- Pull the fuses straight off with needle nose pliers.

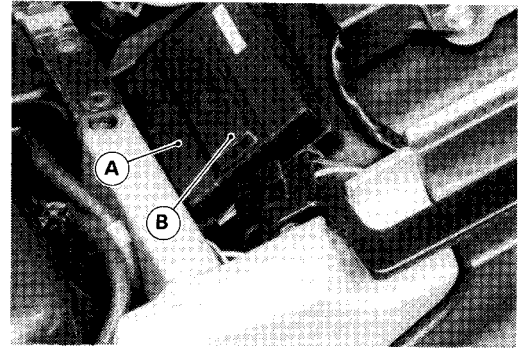

Fuse Installation Note

- Install the specified fuses [A] in place in the junction box in accordance with the arrangement plan on the back of fuse cover.

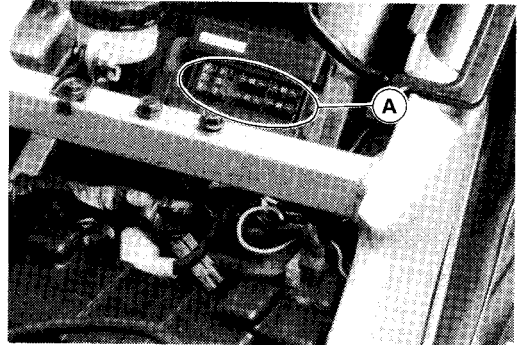

Fuse Inspection

- Remove the fuse from the junction box.
- Inspect the fuse element [A].
- ★ If it is blown out [B], replace the fuse.

NOTE

- Before replacing a blown fuse, always check the amperage in the affected circuit. If the amperage is equal to or greater than the fuse rating, check the wiring and related components for a short circuit.

CAUTION

When replacing a fuse, be sure the new fuse matches the specified fuse rating for that circuit. Installation of a fuse with a high rating may cause damage to wiring and components.

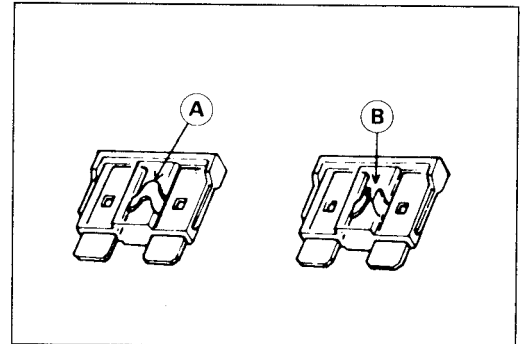

Fuse Circuit Inspection

- Check all fuses, and replace any fuses whose elements are blown out.
- Remove the junction box.
- Make sure all connector terminals are clean and tight, and none of them have been bent.
- ★ Clean the dirty terminals, and straighten slightly-bent terminals.
- Check conductivity of the numbered terminals with a hand tester.
- ★ If the tester does not read as specified, replace the junction box.

Special Tool – Hand Tester: 57001-983

Fuse Circuit Inspection (ZX1100-D1, D2)

Meter Connection	Meter Reading (Ω)
1 - 2	0
1 - 3 A/B	0 * ∞
6 - 7	0
6 - 17	0
1 - 7	∞
3A/B - 8	∞
8 - 17	∞

(*) Other than U.S., Canadian and Australian Model

Fuse Circuit Inspection (ZX1100-D3)

Meter Connection	Meter Reading (Ω)
1 - 2	0
1 - 3B	0
3A - 4	0
6 - 5	0
6 - 7	0
6 - 10	0
6 - 17	0
1 - 4	∞
1 - 5	∞
1 - 7	∞
1 - 10	∞
8 - 3B	∞
8 - 17	∞

Headlight/Starter Circuit Relay Inspection

- Remove the junction box.
- Check conductivity of the following numbered terminal by connecting the hand tester and one 12 V battery to the junction box as shown.
- ★ If the relay does not work as specified, replace the junction box.

Special Tool – Hand Tester: 57001-983

Relay Inspection (with the battery disconnected)

	Tester Connection	Tester Reading (Ω)
Headlight Relay	*7 - 8	∞
	*9 - 13	other than ∞
Starter Circuit Relay	11 - 13	∞
	12 - 13	other than ∞

(*) : U.S., Canadian, and Australian Models only

Relay Inspection (with the battery connected)

	Tester Connection	Battery Connection (+) (-)	Tester Reading (Ω)
Headlight Relay	*7 - 8	*9 - 13	0
Starter Circuit Relay	11 - 13	11 - 12	0

(*) : U.S., Canadian, and Australian Models only

Diode Circuit Inspection

- Remove the junction box.
- Check conductivity of the following pair of terminals.

Diode Circuit Inspection

Tester Connection	*13-8, *13-9, 11-12, 12-14, 15-14, 16-14
-------------------	--

(*) : U.S., Canadian, and Australian Models only

- ★ The resistance should be low in one direction and more than ten times as much in the other direction. If any diode shows low or high in both directions, the diode is defective and the junction box must be replaced.

NOTE

○ The actual meter reading varies with the meter used and the individual diodes, but, generally speaking, the lower reading should be from zero to one half the scale.

ZX1100-D1, D2

Junction Box Internal Circuit
(U.S., Canadian, and Australian Model)

(Other than left Models)

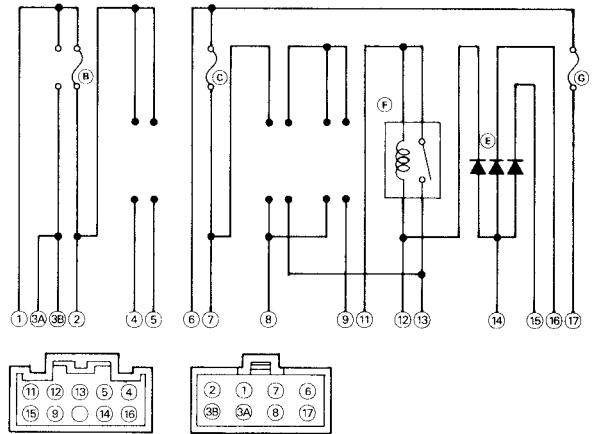
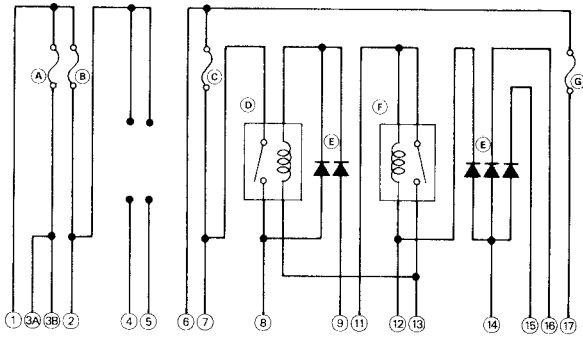

- A. 10A Accessory Fuse
- B. 10A Fan Fuse
- C. 10A Headlight Fuse
- D. Headlight Relay
- E. Diodes
- F. Starter Circuit Relay
- G. 10A Taillight Fuse

ZX1100-D3

(U.S., Canadian and Australian Model)

(Other than left Models)

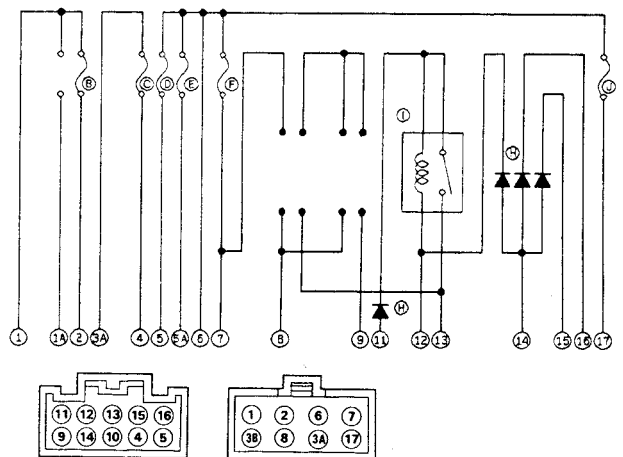
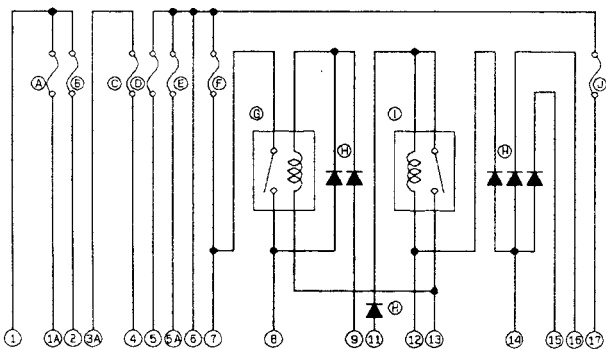

- A. 10A Accessory Fuse
- B. 10A Fun Fuse
- C. 10A Turn Hazard Fuse
- D. 10A Horn Fuse
- E. 10A Ignition Fuse
- F. 10A Headlight Fuse
- G. Headlight Relay
- H. Headlight Diodes
- I. Starter Diode
- J. Starter Circuit Relay
- K. Interlock Diodes
- L. 10A Taillight Fuse

Appendix

Table of Contents

Additional Considerations for Racing	16-2
Carburetor:	16-2
Spark Plug:.....	16-2
Spark Plug Inspection	16-3
Troubleshooting Guide	16-4
Engine Doesn't Start, Starting Difficulty:	16-4
Poor Running at Low Speed:.....	16-4
Poor Running or No Power at High Speed:	16-5
Overheating:	16-5
Over Cooling:	16-5
Clutch Operation Faulty:.....	16-5
Gear Shifting Faulty:.....	16-6
Abnormal Engine Noise:.....	16-6
Abnormal Drive Train Noise:	16-6
Abnormal Frame Noise:	16-6
Oil Pressure Warning Light Goes On:	16-6
Exhaust Smokes Excessively:	16-6
Handling and/or Stability Unsatisfactory:.....	16-7
Brake Doesn't Hold:.....	16-7
Battery Trouble:.....	16-7
General Lubrication.....	16-8
Lubrication	16-8
Nut, Bolt, and Fastener Tightness	16-9
Tightness Inspection	16-9
Unit Conversion Table	16-10
Prefixes for Units:.....	16-10
Units of Mass:.....	16-10
Units of Volume:.....	16-10
Units of Force:	16-10
Units of Length:.....	16-10
Units of Torque:.....	16-10
Units of Pressure:.....	16-10
Units of Speed:	16-10
Units of Power:.....	16-10
Units of Temperature:	16-10

16-2 APPENDIX

Additional Considerations for Racing

This motorcycle has been manufactured for use in a reasonable and prudent manner and as a vehicle only. However, some may wish to subject this motorcycle to abnormal operation, such as would be experienced under racing conditions. **KAWASAKI STRONGLY RECOMMENDS THAT ALL RIDERS RIDE SAFELY AND OBEY ALL LAWS AND REGULATIONS CONCERNING THEIR MOTORCYCLE AND ITS OPERATION.**

Racing should be done under supervised conditions, and recognized sanctioning bodies should be contacted for further details. For those who desire to participate in competitive racing or related use, the following technical information may prove useful. However, please note the following important notes.

- You are entirely responsible for the use of your motorcycle under abnormal conditions such as racing, and Kawasaki shall not be liable for any damages which might arise from such use.
- Kawasaki's Limited Motorcycle Warranty and Limited Emission Control Systems Warranty specifically exclude motorcycles which are used in competition or related uses. Please read the warranty carefully.
- Motorcycle racing is a very sophisticated sport, subject to many variables. The following information is theoretical only, and Kawasaki shall not be liable for any damages which might arise from alterations utilizing this information.
- When the motorcycle is operated on public roads, it **must** be in its original state in order to ensure safety and compliance with applicable regulations.

Carburetor:

Sometimes an alteration may be desirable for improved performance under special conditions when proper mixture is not obtained after the carburetor has been properly adjusted, and all parts cleaned and found to be functioning properly.

If the engine still exhibits symptoms of overly rich or lean carburetion after all maintenance and adjustments are correctly performed, the main jet can be replaced with a smaller or larger one. A smaller numbered jet gives a leaner mixture and a larger numbered jet a richer mixture.

Spark Plug:

The spark plug ignites the fuel and air mixture in the combustion chamber. To do this effectively and at the proper time, the correct spark plug must be used, and the spark plug must be kept clean and the gap adjusted.

Tests have shown the plug listed in the "General Information" chapter to be the best plug for general use.

Since spark plug requirements change with the ignition and carburetion adjustments and with riding conditions, whether or not a spark plug of the correct heat range is used should be determined by removing and inspecting the plug.

- A. Terminal
- B. Insulator
- C. Cement
- D. Gasket
- E. Center Electrode
- F. Gap (0.7 ~ 0.8 mm)
- G. Reach
- H. Side Electrode

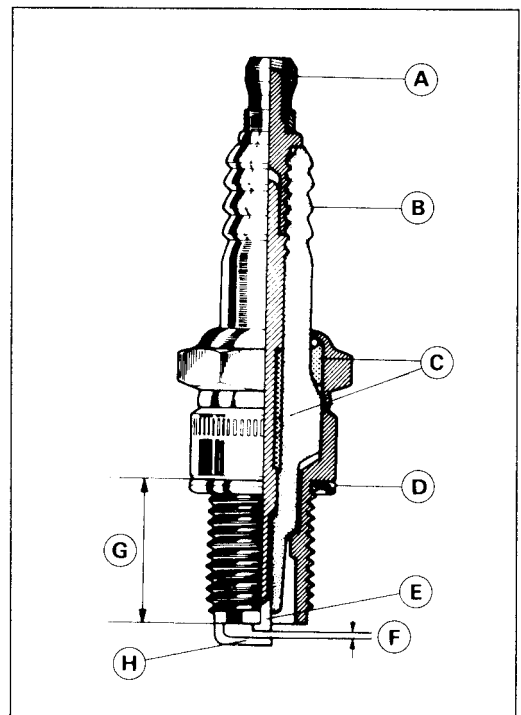

When a plug of the correct heat range is being used, the electrodes will stay hot enough to keep all the carbon burned off, but cool enough to keep from damaging the engine and the plug itself. This temperature is about 400 ~ 800°C (750 ~ 1,450°F) and can be judged by noting the condition and color of the ceramic insulator around the center electrode. If the ceramic is clean and of a light brown color, the plug is operating at the right temperature.

A spark plug for higher operating temperatures is used for racing. Such a plug is designed for better cooling efficiency so that it will not overheat and thus is often called a "colder" plug. If a spark plug with too cool a heat range is used – that is, a "cold" plug that cools itself too well – the plug will stay too cool to burn off the carbon, and the carbon will collect on the electrodes and the ceramic insulator.

The carbon on the electrodes conducts electricity, and can short the center electrode to ground by either coating the ceramic insulator or bridging across the gap. Such a short will prevent an effective spark. Carbon build-up on the plug can also cause other troubles. It can heat up red-hot and cause preignition and knocking, which may eventually burn a hole in the top of the piston.

Spark Plug Inspection

- Remove the spark plug and inspect the ceramic insulator.
- ★ Whether or not the right temperature plug is being used can be ascertained by noting the condition of the ceramic insulator around the electrode. A light brown color indicates the correct plug is being used. If the ceramic is black, it indicates that the plug is firing at too low a temperature, so the next hotter type should be used instead. If the ceramic is white, the plug is operating at too high a temperature and it should be replaced with the next colder type.

CAUTION

If the spark plug is replaced with a type other than the standard plug, make certain the replacement plug has the same thread pitch and reach (length of threaded portion) and the same type electrode (regular type or projected type) as the standard plug.

If the plug reach is too short, carbon will build up on the plug hole threads in the cylinder head, causing overheating and making it very difficult to insert the correct spark plug later.

If the reach is too long, carbon will build up on the exposed spark plug threads causing overheating, preignition, and possibly burning a hole in the piston top. In addition, it may be impossible to remove the plug without damaging the cylinder head.

Standard Spark Plug Threads

- Diameter: 10 mm
- Pitch: 1.25 mm
- Reach: 12.7 mm

NOTE

- The heat range of the spark plug functions like a thermostat for the engine. Using the wrong type of spark plug can make the engine run too hot (resulting in engine damage) or too cold (with poor performance, misfiring, and stalling).

Spark Plug Condition



Carbon fouling



Oil fouling

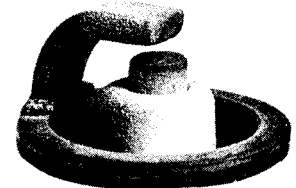

Normal operation

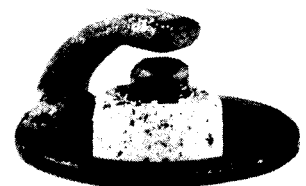

Overheating

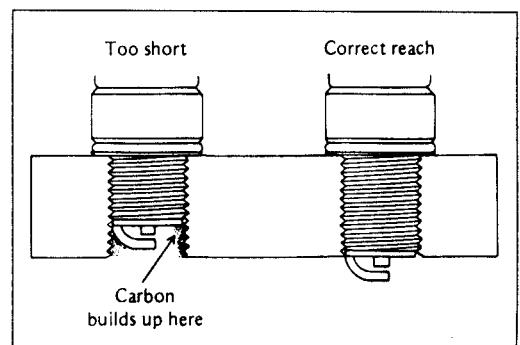

Troubleshooting Guide

NOTE

○ *This is not an exhaustive list, giving every possible cause for each problem listed. It is meant simply as a rough guide to assist the troubleshooting for some of the more common difficulties.*

Engine Doesn't Start, Starting Difficulty:

Starter motor not rotating:

- Starter lockout or neutral switch trouble
- Starter motor trouble
- Battery voltage low
- Starter relays not contacting or operating
- Starter button not contacting
- Wiring open or shorted
- Ignition switch trouble
- Engine stop switch trouble
- Fuse blown

Starter motor rotating but engine doesn't turn over:

- Starter clutch trouble

Engine won't turn over:

- Valve seizure
- Rocker arm seizure
- Cylinder, piston seizure
- Crankshaft seizure
- Connecting rod small end seizure
- Connecting rod big end seizure
- Transmission gear or bearing seizure
- Camshaft seizure
- Alternator shaft bearing seizure
- Balancer bearing seizure
- Balancer bearing seizure

No fuel flow:

- No fuel in tank
- Fuel pump trouble
- Fuel tank air vent obstructed
- Fuel filter clogged
- Fuel tap clogged
- Fuel line clogged
- Float valve clogged

Engine flooded:

- Fuel level in carburetor float bowl too high
- Float valve worn or stuck open
- Starting technique faulty
(When flooded, crank the engine with the throttle fully opened to allow more air to reach the engine.)

No spark; spark weak:

- Battery voltage low
- Spark plug dirty, broken, or maladjusted
- Spark plug cap or high tension wiring trouble
- Spark plug cap shorted or not in good contact
- Spark plug incorrect
- IC igniter trouble
- Neutral, starter lockout, or side stand switch trouble
- Pickup coil trouble
- Ignition coil trouble
- Ignition or engine stop switch shorted
- Wiring shorted or open
- Fuse blown

Fuel/air mixture incorrect:

- Pilot screw and/or idle adjusting screw maladjusted
- Pilot jet, or air passage clogged

- Air cleaner clogged, poorly sealed, or missing
- Starter jet clogged

Compression Low:

- Spark plug loose
- Cylinder head not sufficiently tightened down
- No valve clearance
- Cylinder, piston worn
- Piston ring bad (worn, weak, broken, or sticking)
- Piston ring/groove clearance excessive
- Cylinder head gasket damaged
- Cylinder head warped
- Valve spring broken or weak
- Valve not seating properly (valve bent, worn, or carbon accumulation on the seating surface)

Poor Running at Low Speed:

Spark weak:

- Battery voltage low
- Spark plug dirty, broken, or maladjusted
- Spark plug cap or high tension wiring trouble
- Spark plug cap shorted or not in good contact
- Spark plug incorrect
- IC igniter trouble
- Pickup coil trouble
- Ignition coil trouble

Fuel/air mixture incorrect:

- Pilot screw maladjusted
- Pilot jet, or air passage clogged
- Air bleed pipe bleed holes clogged
- Pilot passage clogged
- Air cleaner clogged, poorly sealed, or missing
- Starter plunger stuck open
- Fuel level in carburetor float bowl too high or too low
- Fuel tank air vent obstructed
- Carburetor holder loose
- Air cleaner duct loose
- Air cleaner O-ring damaged

Compression low:

- Spark plug loose
- Cylinder head not sufficiently tightened down
- No valve clearance
- Cylinder, piston worn
- Piston ring bad (worn, weak, broken, or sticking)
- Piston ring/groove clearance excessive
- Cylinder head warped
- Cylinder head gasket damaged
- Valve spring broken or weak
- Valve not seating properly (valve bent, worn, or carbon accumulation on the seating surface)

Other:

- IC igniter trouble
- Carburetors not synchronizing
- Carburetor vacuum piston doesn't slide smoothly
- Carburetor vacuum piston diaphragm damage
- Engine oil viscosity too high
- Drive train trouble
- Brake dragging
- Air suction valve trouble
- Vacuum switch valve trouble

Poor Running or No Power at High Speed:**Firing incorrect:**

- Spark plug dirty, broken, or maladjusted
- Spark plug cap or high tension wiring trouble
- Spark plug cap shorted or not in good contact
- Spark plug incorrect
- IC igniter trouble
- Pickup coil trouble
- Ignition coil trouble

Fuel/air mixture incorrect:

- Starter plunger stuck open
- Main jet clogged or wrong size
- Jet needle or needle jet worn
- Air jet clogged
- Fuel level in carburetor float bowl too high or too low
- Bleed holes of needle jet holder or needle jet clogged
- Air cleaner clogged, poorly sealed, or missing
- Air cleaner duct loose
- Air cleaner O-ring damaged
- Water or foreign matter in fuel
- Carburetor holder loose
- Fuel tank air vent obstructed
- Fuel tap clogged
- Fuel line clogged
- Fuel pump trouble

Compression low:

- Spark plug loose
- Cylinder head not sufficiently tightened down
- No valve clearance
- Cylinder, piston worn
- Piston ring bad (worn, weak, broken, or sticking)
- Piston ring/groove clearance excessive
- Cylinder head gasket damaged
- Cylinder head warped
- Valve spring broken or weak
- Valve not seating properly (valve bent, worn, or carbon accumulation on the seating surface.)

Knocking:

- Carbon built up in combustion chamber
- Fuel poor quality or incorrect
- Spark plug incorrect
- IC igniter trouble

Miscellaneous:

- Throttle valve won't fully open
- Carburetor vacuum piston doesn't slide smoothly
- Carburetor vacuum piston diaphragm damaged
- Brake dragging
- Clutch slipping
- Overheating
- Engine oil level too high
- Engine oil viscosity too high
- Drive train trouble
- Air suction valve trouble
- Vacuum switch valve trouble
- Balancer mechanism malfunctioning

Overheating:**Firing incorrect:**

- Spark plug dirty, broken, or maladjusted

Spark plug incorrect

IC igniter trouble

Fuel/air mixture incorrect:

- Main jet clogged or wrong size
- Fuel level in carburetor float bowl too low
- Carburetor holder loose
- Air cleaner duct loose
- Air cleaner poorly sealed, or missing
- Air cleaner O-ring damaged
- Air cleaner clogged

Compression high:

- Carbon built up in combustion chamber

Engine load faulty:

- Clutch slipping
- Engine oil level too high
- Engine oil viscosity too high
- Drive train trouble
- Brake dragging

Lubrication inadequate:

- Engine oil level too low
- Engine oil poor quality or incorrect

Oil cooler incorrect:

- Oil cooler fin damaged
- Oil cooler clogged

Gauge incorrect:

- Water temperature gauge broken
- Water temperature sensor broken

Coolant incorrect:

- Coolant level too low
- Coolant deteriorated

Cooling system component incorrect:

- Radiator clogged
- Thermostat trouble
- Radiator cap trouble
- Thermostatic fan switch trouble
- Fan relay trouble
- Fan motor broken
- Fan blase damaged
- Water pump not turning
- Water pump impeller damaged

Over Cooling:**Gauge incorrect:**

- Water temperature gauge broken
- Water temperature sensor broken

Cooling system component incorrect:

- Thermostat fan switch trouble
- Thermostat trouble

Clutch Operation Faulty:**Clutch slipping:**

- Friction plate worn or warped
- Steel plate worn or warped
- Clutch spring broken or weak
- Clutch release mechanism trouble
- Clutch hub or housing unevenly worn

Clutch not disengaging properly:

- Clutch plate warped or too rough
- Clutch spring compression uneven
- Engine oil deteriorated
- Engine oil viscosity too high
- Engine oil level too high

- Clutch housing frozen on drive shaft
- Clutch release mechanism trouble
- Clutch hub nut loose
- Clutch hub spline damaged
- Clutch friction plate installed wrong
- Clutch fluid leakage
- Clutch fluid deteriorated
- Clutch master cylinder primary or secondary cup damaged
- Clutch master cylinder scratched inside

Gear Shifting Faulty:

Doesn't go into gear; shift pedal doesn't return:

- Clutch not disengaging
- Shift fork bent or seized
- Gear stuck on the shaft
- Gear positioning lever binding
- Neutral positioning lever binding
- Shift return spring weak or broken
- Shift return spring pin loose
- Shift mechanism arm spring broken
- Shift mechanism arm broken
- Shift pawl broken

Jumps out of gear:

- Shift fork worn, bent
- Gear groove worn
- Gear dogs and/or dog holes worn
- Shift drum groove worn
- Gear positioning lever spring weak or broken
- Shift fork pin worn
- Drive shaft, output shaft, and/or gear splines worn

Overshifts:

- Gear positioning lever spring weak or broken
- Shift mechanism arm spring broken

Abnormal Engine Noise:

Knocking:

- IC igniter trouble
- Carbon built up in combustion chamber
- Fuel poor quality or incorrect
- Spark plug incorrect
- Overheating

Piston slap:

- Cylinder/piston clearance excessive
- Cylinder, piston worn
- Connecting rod bent
- Piston pin, piston pin hole worn

Valve noise:

- Valve clearance incorrect
- Valve spring broken or weak
- Camshaft bearing worn

Other noise:

- Connecting rod small end clearance excessive
- Connecting rod big end clearance excessive
- Piston ring worn, broken, or stuck
- Piston seizure, damage
- Cylinder head gasket leaking
- Exhaust pipe leaking at cylinder head connection
- Crankshaft runout excessive
- Engine mounts loose

- Crankshaft bearing worn
- Primary gear worn or chipped
- Camshaft chain tensioner trouble
- Camshaft chain, sprocket, guide worn
- Air suction valve damaged
- Vacuum switch valve damaged
- Balancer gear worn or chipped
- Balancer shaft position maladjusted
- Balancer bearing worn
- Balancer or alternator shaft coupling rubber damper damaged
- Alternator shaft chain tensioner trouble
- Alternator shaft chain, sprocket, guide worn

Abnormal Drive Train Noise:

Clutch noise:

- Clutch rubber damper weak or damaged
- Clutch housing/friction plate clearance excessive
- Clutch housing gear worn

Transmission noise:

- Bearings worn
- Transmission gears worn or chipped
- Metal chips jammed in gear teeth
- Engine oil insufficient

Drive chain noise:

- Drive chain adjusted improperly
- Drive chain worn
- Rear and/or engine sprocket worn
- Chain lubrication insufficient
- Rear wheel misaligned

Abnormal Frame Noise:

Front fork noise:

- Oil insufficient or too thin
- Spring weak or broken

Rear shock absorber noise:

- Shock absorber damaged

Disc brake noise:

- Pad installed incorrectly
- Pad surface glazed
- Disc warped
- Caliper trouble

Other noise:

- Bracket, nut, bolt, etc. not properly mounted or tightened

Oil Pressure Warning Light Goes On:

- Engine oil pump damaged
- Engine oil screen clogged
- Engine oil level too low
- Engine oil viscosity too low
- Camshaft bearings worn
- Crankshaft bearings worn
- Oil pressure switch damaged
- Wiring faulty
- Relief valve stuck open
- O-ring at the oil passage in the crankcase damaged

Exhaust Smokes Excessively:

White smoke:

- Piston oil ring worn

Cylinder worn
 Valve oil seal damaged
 Valve guide worn
 Engine oil level to high

Black smoke:

Air cleaner clogged
 Main jet too large or fallen off
 Starter plunger stuck open
 Fuel level in carburetor float bowl too high

Brown smoke:

Main jet too small
 Fuel level in carburetor float bowl too low
 Air cleaner duct loose
 Air cleaner O-ring damaged
 Air cleaner poorly sealed or missing

Handling and/or Stability Unsatisfactory:**Handlebar hard to turn:**

Cable routing incorrect
 Hose routing incorrect
 Wiring routing incorrect
 Steering stem locknut too tight
 Steering stem bearing damaged
 Steering stem bearing lubrication inadequate
 Steering stem bent
 Tire air pressure too low

Handlebar shakes or excessively vibrates:

Tire worn
 Swing arm pivot bearings worn
 Rim warped, or not balanced
 Wheel bearing worn
 Handlebar clamp loose
 Steering stem head nut loose

Handlebar pulls to one side:

Frame bent
 Wheel misalignment
 Swing arm bent or twisted
 Steering maladjusted
 Front fork bent
 Right and left front fork oil level uneven
 Right and left rear shock absorber adjustment uneven

Shock absorption unsatisfactory:

(Too hard)
 Front fork oil excessive
 Front fork oil viscosity too high
 Rear shock absorber adjustment too hard
 Tire air pressure too high
 Front fork bent
 (Too soft) '
 Tire air pressure too low
 Front fork oil insufficient and/or leaking
 Front fork oil viscosity too low
 Rear shock adjustment too soft
 Front fork, rear shock absorber spring weak
 Rear shock absorber oil leaking

Disc warped
 Contaminated pad
 Brake fluid deteriorated
 Primary or secondary cup damaged in master cylinder
 Master cylinder scratched inside

Battery Trouble:**Battery discharged:**

Battery faulty (e.g., plates sulphated, shorted through sedimentation, electrolyte insufficient)
 Battery leads making poor contact
 Load excessive (e.g., bulb of excessive wattage)
 Ignition switch trouble
 Alternator trouble
 Wiring faulty

Battery overcharged:

Alternator trouble
 Battery faulty

Brake Doesn't Hold:

Air in the brake line
 Pad or disc worn
 Brake fluid leakage

16-8 APPENDIX

General Lubrication

Lubrication

- Before lubricating each part, clean off any rusty spots with rust remover and wipe off any grease, oil, dirt, or grime.
- Lubricate the points listed below with indicated lubricant.

NOTE

- *Whenever the vehicle has been operated under wet or rainy conditions, or especially after using a high-pressure water spray, perform the general lubrication.*

Pivots: Lubricate with Motor Oil.

- Clutch Lever
- Brake Lever
- Brake Pedal
- Center Stand
- Side Stand
- Rear Brake Rod Joint

Points: Lubricate with Grease.

- Throttle Inner Cable Lower Ends
- Choke Inner Cable Lower End
- Speedometer Inner Cable*

(*): Grease the lower part of the inner cable sparingly.

Cables: Lubricate with Rust Inhibiter.

- Choke Cable
- Throttle Cables

Special Tool – Pressure Cable Luber: K56019-021 [A]

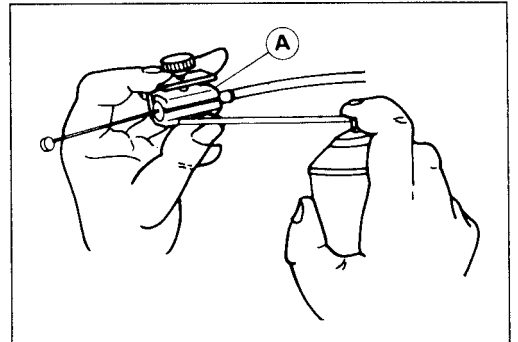

Nut, Bolt and Fastener Tightness

Tightness Inspection

- Check the tightness of the bolts and nuts listed here. Also, check to see that each cotter pin is in place and in good condition.

NOTE

○ *For the engine fasteners, check the tightness of them when the engine is cold (at room temperature).*

- ★ If there are loose fasteners, retorque them to the specified torque following the specified tightening sequence. Refer to the appropriate chapter for torque specifications. If torque specifications are not in the appropriate chapter, see the Standard Torque Table. For each fastener, first loosen it by 1/2 turn, then tighten it.

- ★ If cotter pins are damaged, replace them with new ones.

Nut, Bolt and Fastener to be checked

Wheels:

- Front Axle Nut
- Front Axle Clamp Bolts
- Rear Axle Nut
- Chain Adjuster Clamp Bolts

Brakes:

- Front Master Cylinder Clamp Bolts
- Caliper Mounting Bolts
- Rear Master Cylinder Mounting Bolts
- Torque Link Nut, Cotter Pin
- Brake Lever Pivot Nut
- Brake Pedal Bolt
- Brake Rod Joint Cotter Pin

Suspension:

- Front Fork Clamp Bolts
- Front Fender Mounting Bolts
- Rear Shock Absorber Mounting Bolts
- Swing Arm Pivot Shaft Nut

Steering:

- Stem Head Nut
- Handlebar Clamp Bolts

Engine:

- Engine Mounting Bolts
- Cylinder Head Bolts
- Muffler Mounting Bolts
- Exhaust Pipe Holder Nuts
- Muffler Connecting Clamp Bolt
- Clutch Master Cylinder Clamp Bolts
- Clutch Lever Pivot Nut

Others:

- Center Stand Bolts
- Side Stand Bolt
- Footpeg Mounting Bolts
- Down Tube Mounting Bolts
- Footpeg Bracket Mounting Bolts

MODEL APPLICATION

Year	Model	Beginning Frame No.
1993	ZX1100-D1	JKAZXBD1□PA00□01, or ZXT10D-000001
1994	ZX1100-D2	JKAZXBD1□RA020001, or ZXT10D-020001
1995	ZX1100-D3	JKAZXBD1□SA032001, or ZXT10D-032001

□ : This digit in the frame number changes from one machine to another.

KAWASAKI
HEAVY INDUSTRIES, LTD.
CONSUMER PRODUCTS GROUP