

POWER SOURCE

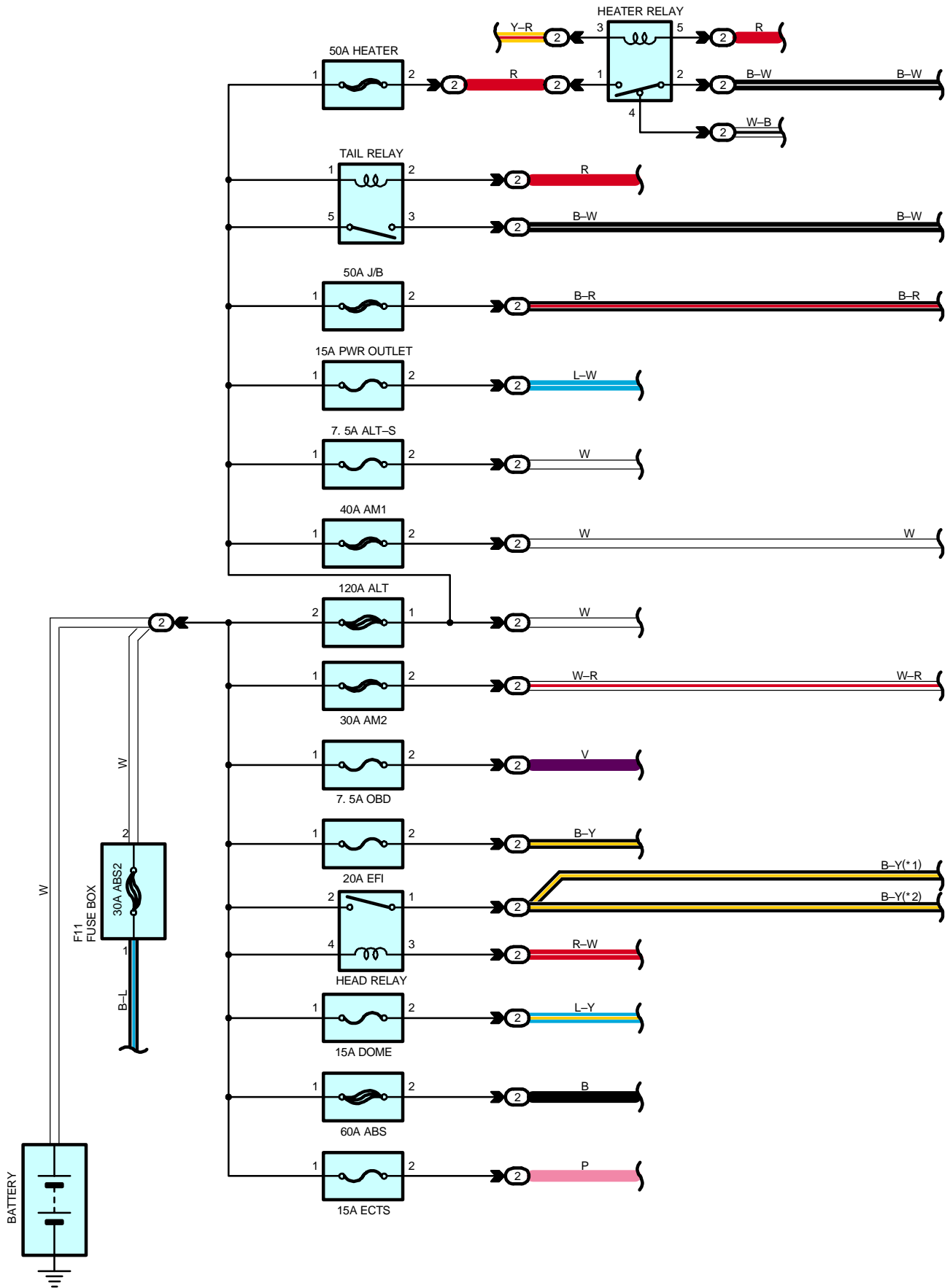

* 1 : W/O DAYTIME RUNNING LIGHT
 * 2 : W/ DAYTIME RUNNING LIGHT

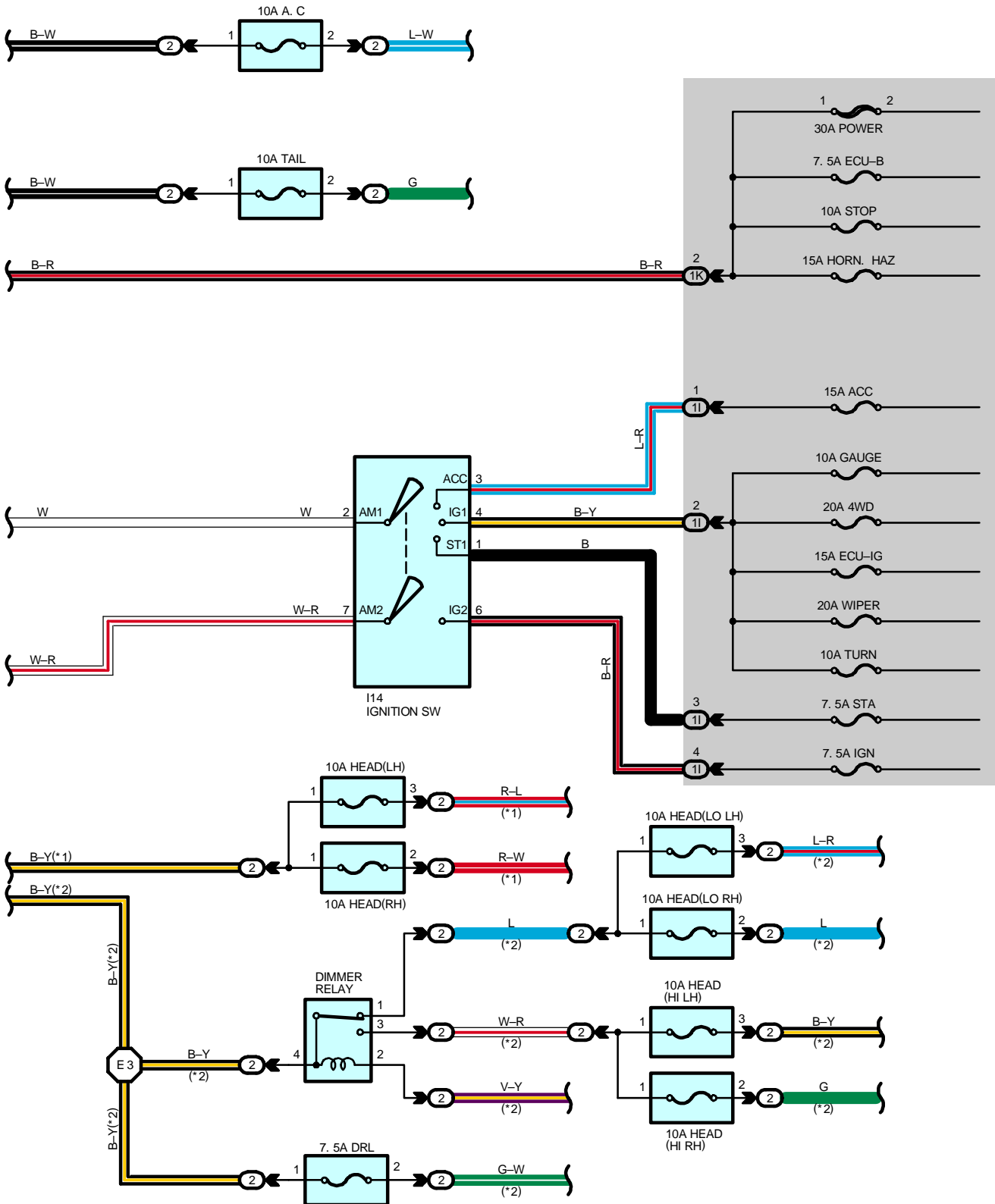

POWER SOURCE

SERVICE HINTS

HEATER RELAY

1-2 : Closed with ignition SW on and heater blower SW on

HEAD RELAY

2-1 : Closed with light control SW at **HEAD** position or dimmer SW at **FLASH** position
 Closed with engine running and parking brake lever released (w/ daytime running light)

I14 IGNITION SW

2-3 : Closed with ignition key at **ACC** or **ON** position
 2-4 : Closed with ignition key at **ON** or **ST** position
 7-6 : Closed with ignition key at **ON** or **ST** position

TAIL RELAY

5-3 : Closed with light control SW at **TAIL** or **HEAD** position

DIMMER RELAY

4-3 : Closed with HEAD relay on and dimmer SW at **HIGH** or **FLASH** position

○ : PARTS LOCATION

Code	See Page	Code	See Page	Code	See Page
I14	35				

○ : RELAY BLOCKS

Code	See Page	Relay Blocks (Relay Block Location)
2	21	R/B No.2 (Engine Compartment Left)

○ : JUNCTION BLOCK AND WIRE HARNESS CONNECTOR

Code	See Page	Junction Block and Wire Harness (Connector Location)
1I	23	Engine Room Main Wire and J/B No.1 (Lower Finish Panel)
1K		

○ : SPLICE POINTS

Code	See Page	Wire Harness with Splice Points	Code	See Page	Wire Harness with Splice Points
E3	40 (5VZ-FE)	Engine Room Main Wire	E3	42 (3RZ-FE, 2RZ-FE)	Engine Room Main Wire

