

## INSTALLATION

### 1. INSTALL PS VANE PUMP ASSEMBLY

Install the PS vane pump assembly with the 2 bolts.

**Torque: 39 N·m (398 kgf·cm, 29 ft·lbf)**

### 2. CONNECT RETURN HOSE

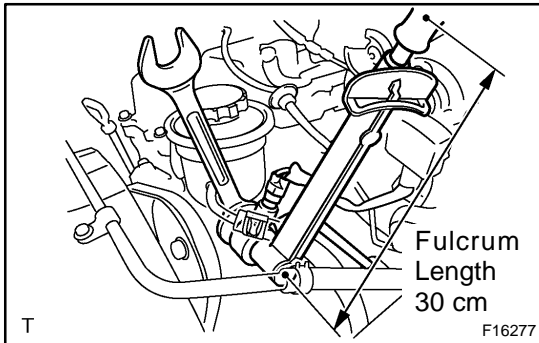

### 3. INSTALL PRESSURE FEED TUBE

Install the union bolt with a new gasket on each side of the tube.

**Torque: 47 N·m (479 kgf·cm, 35 ft·lbf)**

HINT:

- Use a torque wrench with a fulcrum length of 30 cm (11.81in.).
- Make sure the stopper of the tube is touching the PS pump body as shown, then torque the union bolt.

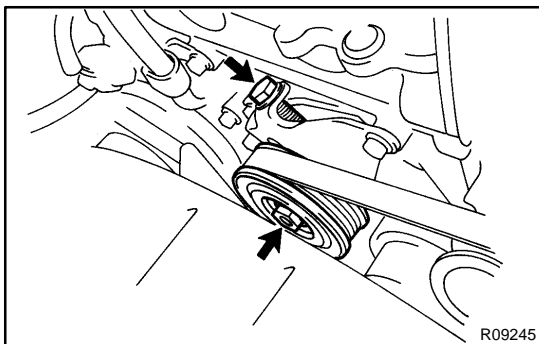
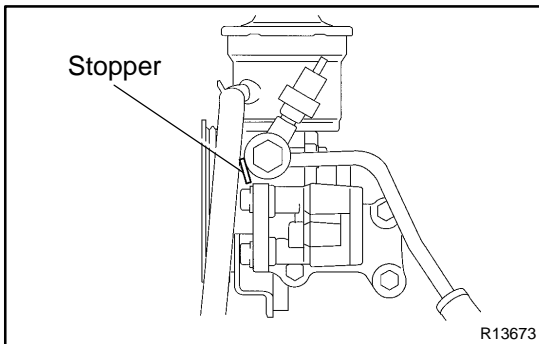

### 4. INSTALL DRIVE BELT

(a) Tightening the belt adjusting bolt and adjust drive belt tension (See page [SR-3](#)).

(b) Torque the power steering idle pulley set nut.

**Torque: 39 N·m (398 kgf·cm, 29 ft·lbf)**

### 5. BLEED POWER STEERING SYSTEM (See page [SR-4](#))