

# SFI SYSTEM PRECAUTION

SF10E-03

## 1. BEFORE WORKING ON FUEL SYSTEM, DISCONNECT NEGATIVE (-) TERMINAL CABLE FROM BATTERY

### HINT:

Any diagnostic trouble code retained by the computer will be erased when the negative (-) terminal cable is removed from the battery.

Therefore, if necessary, read the diagnosis before removing the negative (-) terminal cable from the battery.

## 2. DO NOT SMOKE OR WORK NEAR AN OPEN FLAME WHEN WORKING ON FUEL SYSTEM

## 3. KEEP GASOLINE AWAY FROM RUBBER OR LEATHER PARTS

## 4. MAINTENANCE PRECAUTIONS

(a) In the event of engine misfire, these precautions should be taken.

- (1) Check proper connection to battery terminals, etc.
- (2) After repair work, check that the ignition coil terminals and all other ignition system lines are reconnected securely.
- (3) When cleaning the engine compartment, be especially careful to protect the electrical system from water.

(b) Precautions when the handling oxygen sensors.

- (1) Do not allow oxygen sensor to drop or hit against an object.
- (2) Do not allow the sensor to come into contact with water.

## 5. IF VEHICLE IS EQUIPPED WITH MOBILE RADIO SYSTEM (HAM, CB, ETC.)

If the vehicle is equipped with a mobile communication system, refer to the precaution in the IN section.

## 6. AIR INDUCTION SYSTEM

- (a) Separation of the engine oil dipstick, oil filler cap, PCV hose, etc. may cause the engine to run out of tune.
- (b) Disconnection, looseness or cracks in the parts of the air induction system between the throttle body and cylinder head will allow air suction and cause the engine to run out of tune.

## 7. ELECTRONIC CONTROL SYSTEM

- (a) Before removing SFI wiring connectors, terminals, etc., first disconnect the power by either turning the ignition switch OFF or disconnecting the negative (-) terminal cable from the battery.

### HINT:

Always check the diagnostic trouble code before disconnecting the negative (-) terminal cable from the battery.

- (b) When installing the battery, be especially careful not to incorrectly connect the positive (+) and negative (–) cables.
- (c) Do not permit parts to receive a severe impact during removal or installation. Handle all SFI parts carefully, especially the ECM.
- (d) Be careful during troubleshooting as there are numerous transistor circuit, and even slight terminal contact can cause further troubles.
- (e) Do not open the ECM cover.
- (f) When inspecting during rainy weather, take care to prevent entry of water. Also, when washing the engine compartment, prevent water from getting on the SFI parts and wiring connectors.
- (g) Parts should be replaced as an assembly.
- (h) Care should be taken when pulling out and inserting wiring connectors.
  - (1) Release the lock and pull out the connector, pulling on the connectors.
  - (2) Fully insert the connector and check that it is locked.

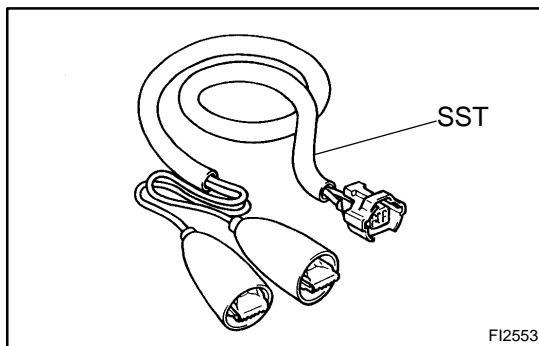

- (i) Use SST for inspection or test of the injector or its wiring connector.  
SST 09842–30070

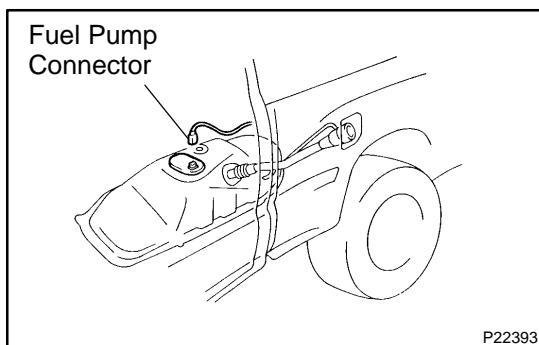

## 8. FUEL SYSTEM

- (a) When disconnecting the high fuel pressure line, a large amount of gasoline will spill out, so observe these procedures:
  - (1) Disconnect the fuel pump connector.
  - (2) Start the engine. After the engine has stopped on its own, turn the ignition switch OFF.
  - (3) Put a container under the connection.
  - (4) Slowly loosen the connection.
  - (5) Disconnect the connection.
  - (6) Plug the connection with a rubber plug.

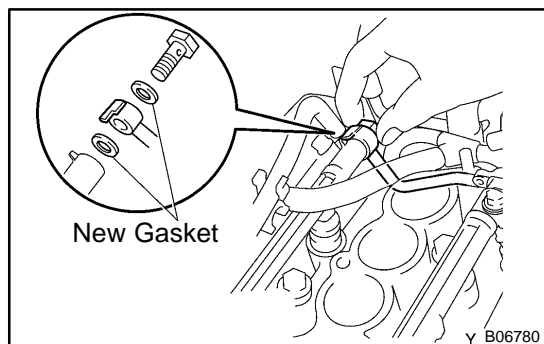

- (b) When connecting the union bolt on the high pressure pipe union, observe these procedures:
- (1) Always use 2 new gaskets.
  - (2) Tighten the union bolt by hand.
  - (3) Tighten the union bolt to the specified torque.
- Torque: 34.3 N·m (350 kgf·cm, 25 ft·lbf)**

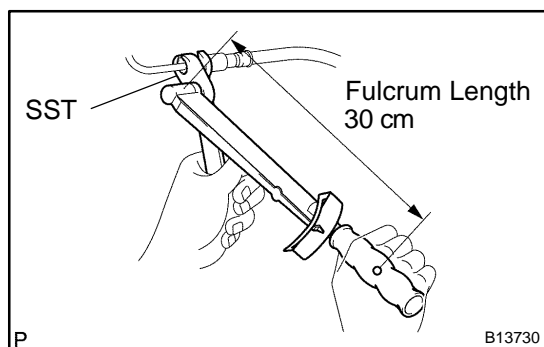

- (c) When connecting the flare nut on the high pressure pipe union, observe these procedures:
- (1) Apply a light coat of engine oil to the flare and tighten the flare nut by hand.
  - (2) Using SST, tighten the flare nut to the specified torque.

SST 09023-38400

**Torque: 24 N·m (245 kgf·cm, 18 ft·lbf)**

**HINT:**

Use a torque wrench with a fulcrum length of 30 cm (11.81 in.).

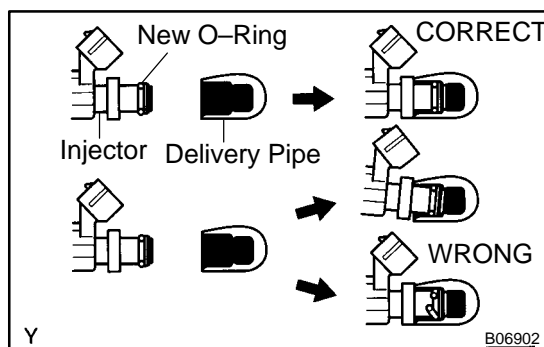

- (d) Observe these precautions when removing and installing the injectors.
- (1) Never reuse the O-ring.
  - (2) When placing a new O-ring on the injector, take care not to damage it in any way.
  - (3) Coat a new O-ring with spindle oil or gasoline before installing—never use engine, gear or brake oil.

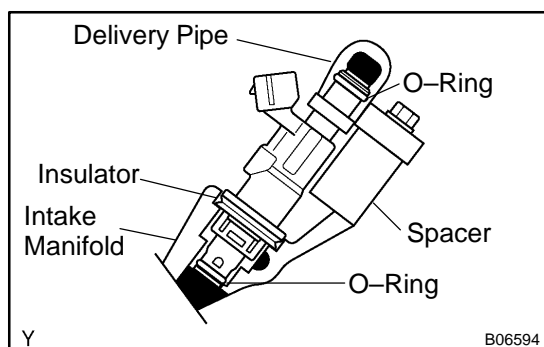

- (e) Install the injector to the delivery pipe and intake manifold, as shown in the illustration.

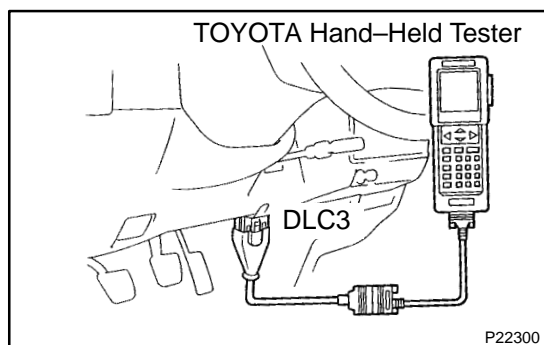

- (f) Check that there are no fuel leaks after doing maintenance anywhere on the fuel system.
- (1) Connect a TOYOTA hand-held tester to the DLC3.
  - (2) Turn the ignition switch ON and push TOYOTA hand-held tester main switch ON.

**NOTICE:**

**Do not start the engine.**

- (3) Select the ACTIVE TEST mode on the TOYOTA hand-held tester.

- (4) Please refer to the TOYOTA hand-held tester operator's manual for further details.
- (5) If you have no TOYOTA hand-held tester, connect the positive (+) and negative (-) leads from the battery to the fuel pump connector.  
(See page [SF-5](#))

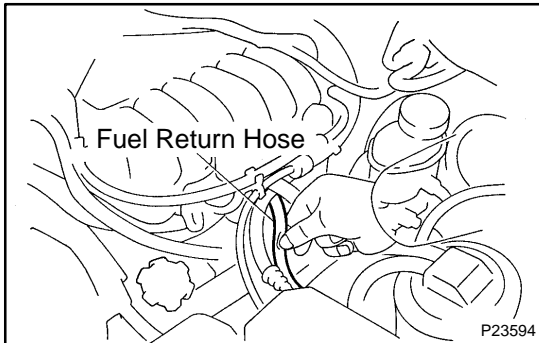

- (6) Pinch the fuel return hose.  
The pressure in the high pressure line will rise to approx. 400 kPa (4 kgf/cm<sup>2</sup>, 57 psi). In this state, check to see that there are no leaks from any part of the fuel system.

**NOTICE:**

**Always pinch the hose. Avoid bending as it may cause the hose to crack.**

- (7) Turn the ignition switch OFF.
- (8) Disconnect the TOYOTA hand-held tester from the DLC3.