

INSPECTION

1. INSPECT INJECTOR RESISTANCE

Using an ohmmeter, measure the resistance between the terminals.

Resistance: Approx. 13.8 Ω at 20°C (68°F)

If the resistance is not as specified, replace the injector.

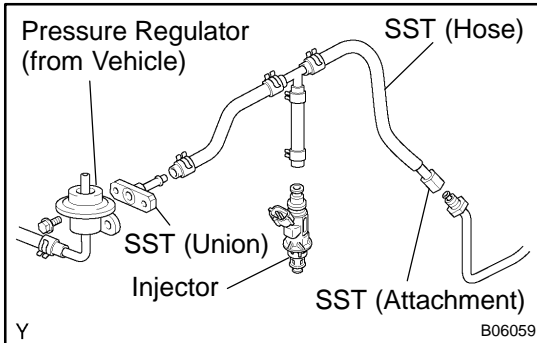

2. INSPECT INJECTOR INJECTION

CAUTION:

Keep injector clear of sparks during the test.

- Disconnect the fuel inlet pipe from the fuel tube.
SST 09268-41047 (09268-52011)
- Connect SST (attachment and hose) to the fuel tube.
SST 09268-41047 (09268-41091)
- Connect the fuel return hose, SST (union) and SST (hose) to the fuel pressure regulator.
SST 09268-41047 (09268-41091)

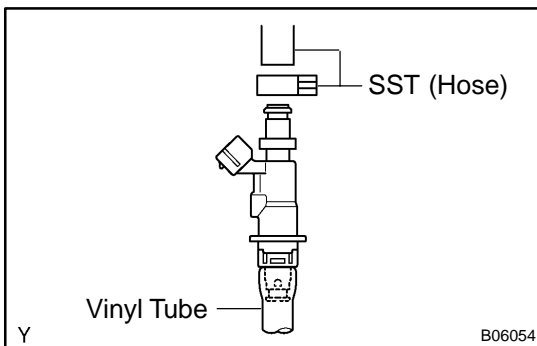

- Connect SST (hose) to the injector.
SST 09268-41047

- Put the injector into the graduated cylinder.

HINT:

Install a suitable vinyl hose onto the injector to prevent gasoline from splashing out.

- Connect a TOYOTA hand-held tester to the DLC3
(See page [EM-9](#)).

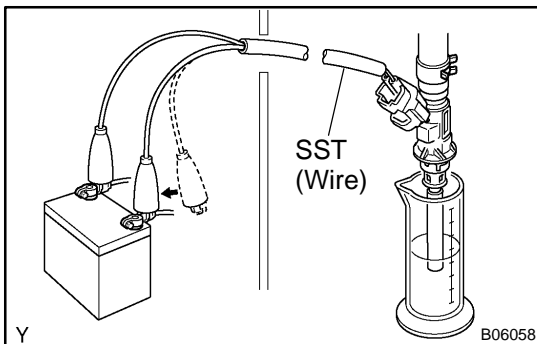

- Connect SST (wire) to the injector and battery for 15 seconds, and measure the injection volume with a graduated cylinder. Test each injector 2 or 3 times.
SST 09842-30070

Volume: 56 – 69 cm³ (3.4 – 4.2 cu in.) per 15 sec.

Difference between each injector:

1.3 cm³ (0.08 cu in.) or less

If the injection volume is not as specified, replace the injector.

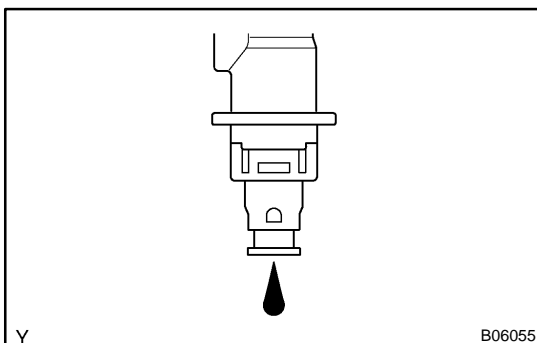

3. INSPECT LEAKAGE

- In the condition above, disconnect the tester probes of SST (wire) from the battery and check the fuel leakage from the injector.
SST 09842-30070

Fuel drop: 1 drop or less per 12 minutes

Fuel drop: 1 drop or less per 12 minutes

- Turn the ignition switch OFF.
- Disconnect the negative (-) terminal cable from the battery.

- (d) Remove the SST.
SST 09268-41047, 09842-30070
- (e) Disconnect the TOYOTA hand-held tester from the DLC3.