

## DISPOSAL

### HINT:

When scrapping vehicle equipped with an SRS or disposing of a steering wheel pad (with airbag), always first deploy the airbag in accordance with the procedure described below. If any abnormality occurs with the airbag deployment, contact the SERVICE DEPT. of TOYOTA MOTOR SALES, U.S.A., INC.

### CAUTION:

- Never dispose of a steering wheel pad which has an undeployed airbag.
- The airbag produces a sizeable exploding sound when it deploys, so perform the operation out-of-doors and where it will not create a nuisance to nearby residents.

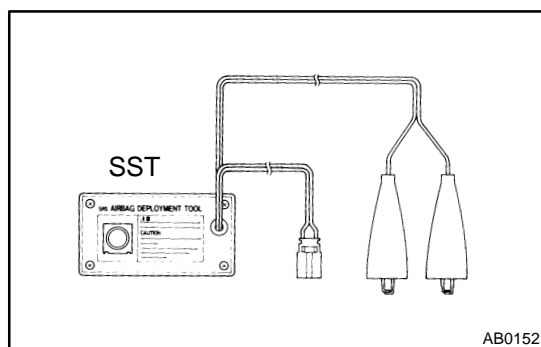

- When deploying the airbag, always use the specified SST (SRS Airbag Deployment Tool). Perform the operation in a place away from electrical noise.

SST 09082-00700

- When deploying an airbag, perform the operation at least 10 m (33 ft) away from the steering wheel pad.
- The steering wheel pad is very hot when the airbag is deployed, so leave it alone for at least 30 minutes after deployment.
- Use gloves and safety glasses when handling a steering wheel pad with the deployed airbag.
- Always wash your hands with water after completing the operation.
- Do not apply water, etc. to a steering wheel pad with the deployed airbag.

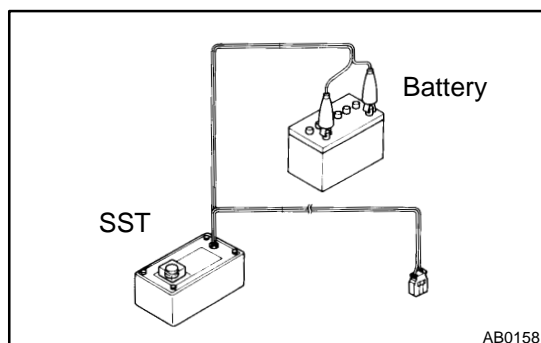

### 1. AIRBAG DEPLOYMENT WHEN SCRAPPING VEHICLE

#### HINT:

Have a battery ready as the power source to deploy the airbag.

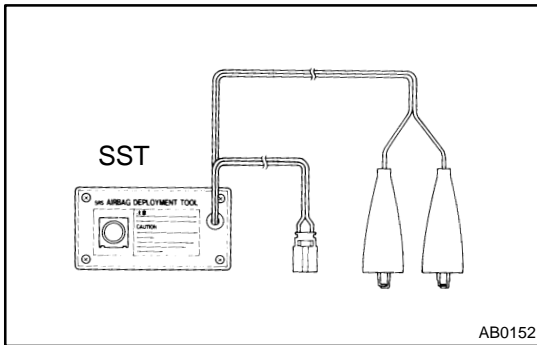

(a) Check functioning of the SST.

**CAUTION:**

**When deploying the airbag, always use the specified SST: SRS Airbag Deployment Tool.**

SST 09082-00700

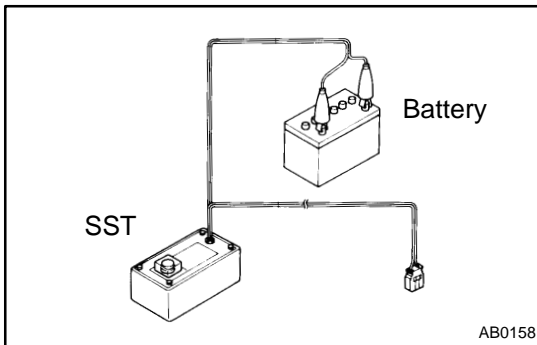

- (1) Connect the red clip of the SST to the battery positive (+) terminal and the black clip to the battery negative (-) terminal.

**HINT:**

Do not connect the yellow connector which will be connected with the supplemental restraint system.

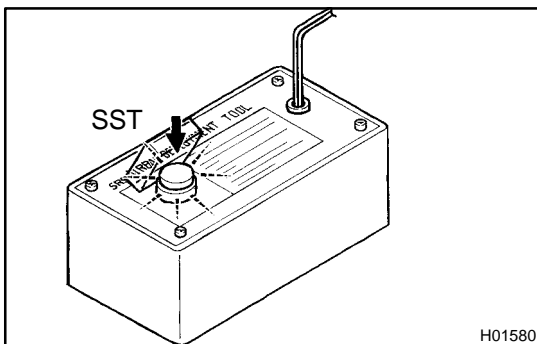

- (2) Press the SST activation switch, and check that the LED of the SST activation switch lights up.

**CAUTION:**

**If the LED lights up when the activation switch is not being pressed, SST malfunction is probable, so definitely do not use the SST.**

- (3) Disconnect the SST from the battery.

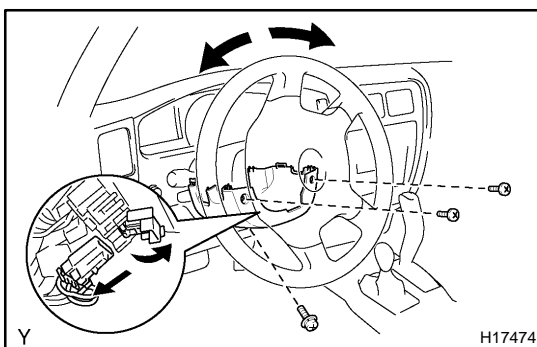

(b) Install the SST.

**CAUTION:**

**Check that there is no looseness in the steering wheel and steering wheel pad.**

- (1) Remove the steering column lower cover. Remove the 3 screws and steering column lower cover as shown in the illustration.
- (2) Disconnect the airbag connector of the spiral cable.

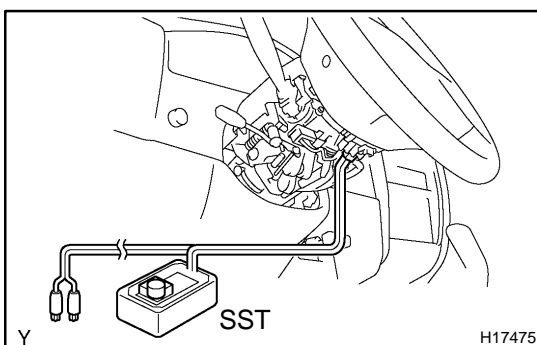

- (3) Connect the connector of the SST to the airbag connector of the spiral cable.

SST 09082-00700

**NOTICE:**

**To avoid damaging the connector of the SST and wire harness, do not lock the secondary lock of the twin lock.**

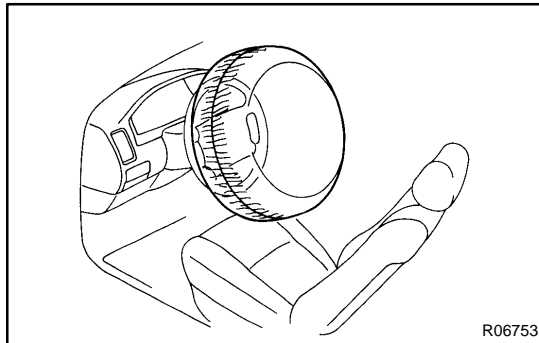
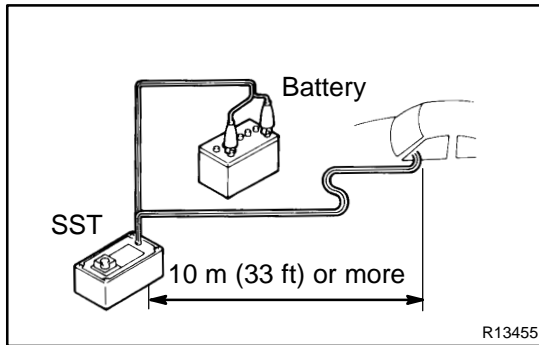

- (4) Move the SST at least 10 m (33 ft) away from the front of the vehicle.
- (5) Close all the doors and windows of the vehicle.

**NOTICE:**

**Take care not to damage the SST wire harness.**

- (6) Connect the SST red clip to the battery positive (+) terminal and the black clip to the negative (-) terminal.

- (c) Deploy the airbag.

- (1) Check that no one is inside the vehicle or within 10 m (33 ft) area around the vehicle.
- (2) Press the SST activation switch and deploy the airbag.

**CAUTION:**

- **The steering wheel pad is very hot when the airbag is deployed, so leave it alone for at least 30 minutes after deployment.**
- **Use gloves and safety glasses when handling a steering wheel pad with the deployed airbag.**
- **Always wash your hands with water after completing the operation.**
- **Do not apply water, etc. to a steering wheel pad with the deployed airbag.**
- **When scrapping a vehicle, deploy the airbag and scrap the vehicle with the steering wheel pad still installed.**
- **When moving a vehicle for scrapping which has a steering wheel pad with deployed airbag, use gloves and safety glasses.**

**HINT:**

The airbag deploys simultaneously as the LED of the SST activation switch lights up.

## 2. DEPLOYMENT WHEN DISPOSING OF STEERING WHEEL PAD ONLY

**NOTICE:**

- **When disposing of the steering wheel pad (with airbag) only, never use the customer's vehicle to deploy the airbag.**
- **Be sure to follow the procedure given below when deploying the airbag.**

**HINT:**

Have a battery ready as the power source to deploy the airbag.

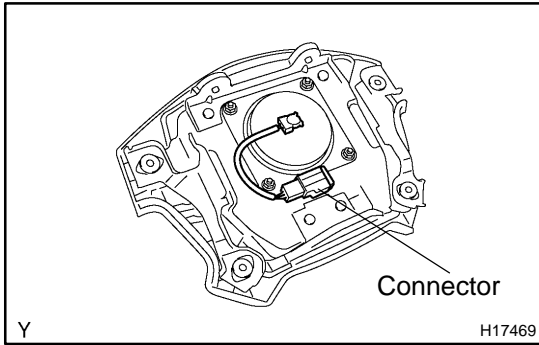

(a) Remove the steering wheel pad (See page SR-14).

**CAUTION:**

- When removing the steering wheel pad, work must be started 90 seconds after the ignition switch is turned to the "LOCK" position and the negative (-) terminal cable is disconnected from the battery.
- When storing the steering wheel pad, keep the upper surface of the pad facing upward.

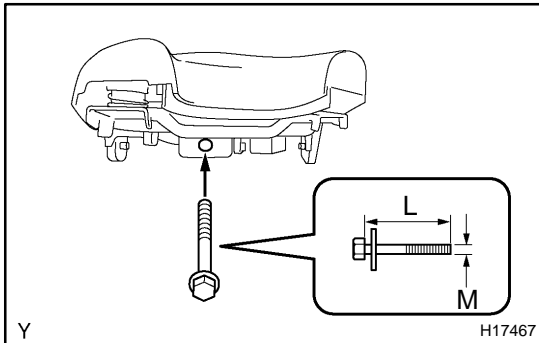

(b) Fix the steering wheel pad to the disc wheel with tire.  
 (1) Install the 2 bolts with washers in the 2 bolt holes in the steering wheel pad.

**Bolt:**

**L: 35. mm (1.387 in.)**

**M: 6.0 mm (0.236 in.)**

**Pitch: 1.0 mm (0.039 in.)**

**NOTICE:**

- Tighten the bolts by hand until the bolts become difficult to turn.
- Do not tighten the bolts too much.

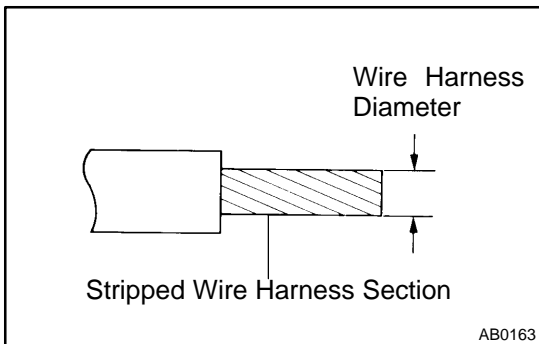

(2) Using a service-purpose wire harness tie down the steering wheel pad to the disc wheel.

**Wire harness: Stripped wire harness section  
 1.25 mm<sup>2</sup> or more (0.0019 in<sup>2</sup>. or more)**

**CAUTION:**

If a wire harness which is too thin or some other thing is used to tie down the steering wheel pad, it may be snapped by the shock when the airbag is deployed. This is highly dangerous. Always use a wire harness for vehicle use which is at least 1.25 mm<sup>2</sup> (0.0019 in<sup>2</sup>.).

**HINT:**

To calculate the square of the stripped wire harness section:

$$\text{Square} = 3.14 \times (\text{Diameter})^2 \text{ divided by } 4$$

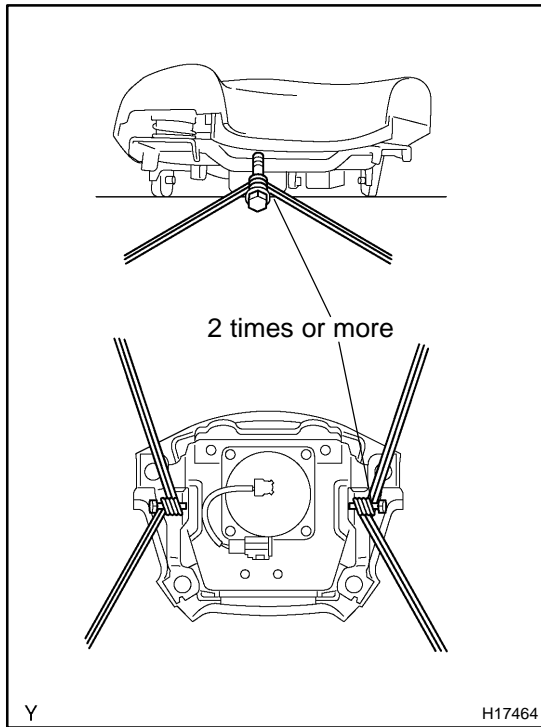

- (3) Using 3 wire harness, wind the wire harness at least 2 times each around the bolts installed on the left and right sides of the steering wheel pad.

**CAUTION:**

- **Tightly wind the wire harness around the bolts so that there is no slack.**
- **If there is slackness in the wire harness, the steering wheel pad may come loose due to the shock when the airbag is deployed. This is highly dangerous.**

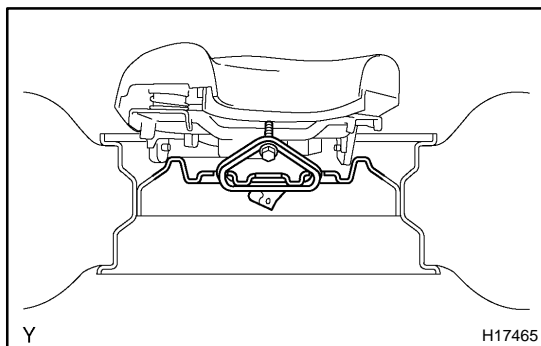

- (4) Face the upper surface of the steering wheel pad upward. Separately tie the left and right sides of the steering wheel pad to the disc wheel through the hub nut holes. Position the steering wheel pad connector so that it hangs downward through a hub hole in the disc wheel.

**CAUTION:**

- **Make sure that the wire harness is tight. It is very dangerous when looseness in the wire harness results in the steering wheel pad coming free due to the shock from the airbag deploying.**
- **Always tie down the steering wheel pad with the pad side facing upward. It is very dangerous if the steering wheel pad is tied down with the metal surface facing upward as the wire harness will be cut by the shock from the airbag deploying and the steering wheel pad will be thrown into the air.**

**NOTICE:**

The disc wheel will be marked by airbag deployment, so when disposing of the airbag use a redundant disc wheel.

- (c) Check functioning of the SST (See step 1-(a)).

SST 09082-00700

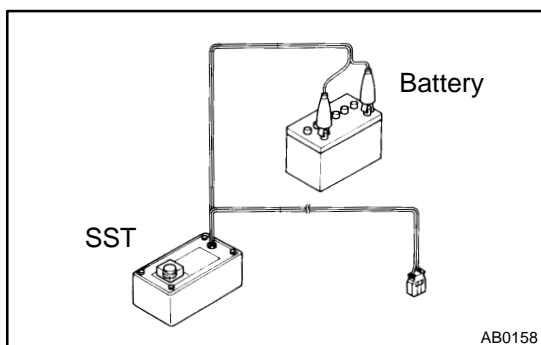

## SUPPLEMENTAL RESTRAINT SYSTEM – STEERING WHEEL PAD AND SPIRAL CABLE

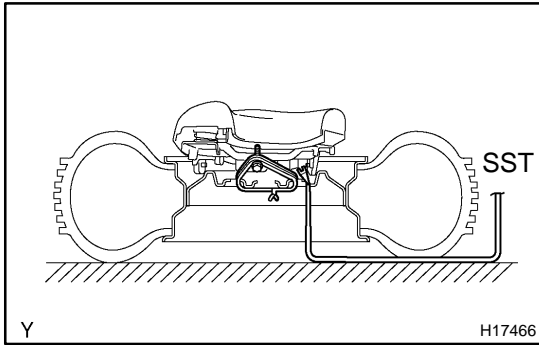

(d) Install the SST.

**CAUTION:**

**Place the disc wheel on the level ground.**

- (1) Connect the connector of the SST to the steering wheel pad connector.

SST 09082-00700, 09082-00760

**NOTICE:**

**To avoid damaging the SST connector and wire harness, do not lock the secondary lock of the twin lock. Also, secure some slack for the SST wire harness inside the disc wheel.**

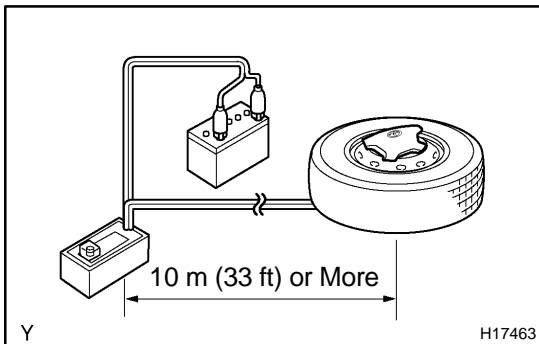

- (2) Move the SST to at least 10 m (33 ft) away from the steering wheel pad tied down on the disc wheel.

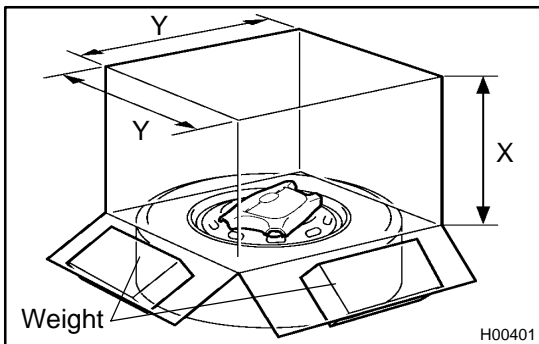

- (e) Cover the steering wheel pad with a cardboard box or tires.

- Covering method using a cardboard box:  
Cover the steering wheel pad with the cardboard box and weight the cardboard box down in 4 places with at least 190 N (20 kg, 44 lb).

**Size of cardboard box:**

**Must exceed the following dimensions:**

**X = 460 mm (18.11 in.)**

**Y = 650 mm (25.59 in.)**

**NOTICE:**

- **When dimension Y of the cardboard box exceeds the diameter of the disc wheel with tire to which the steering wheel pad is tied, X should be the following size.**  
**X = 460 mm (18.11 in.) + width of tire**
- **If a cardboard box smaller than the specified size is used, the cardboard box will be broken by the shock from the airbag deployment.**

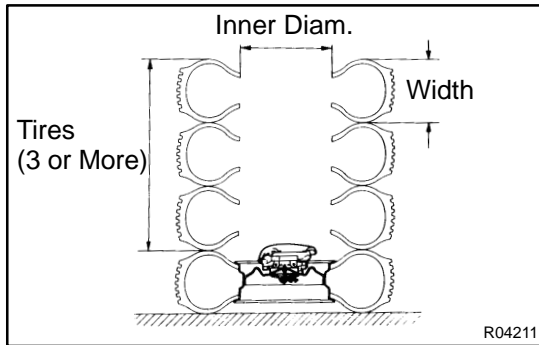

- Covering method using tires:  
Place at least 3 tires without disc wheel on top of the disc wheel with tire to which the steering wheel pad is tied.

**Tire size: Must exceed the following dimensions–**

**Width: 185 mm (7.87 in.)**

**Inner diameter: 360 mm (14.17 in.)**

**CAUTION:**

**Do not use tires with disc wheels.**

**NOTICE:**

**The tires may be marked by the airbag deployment, so use the redundant tires.**

(f) Deploy the airbag.

- (1) Connect the SST red clip to the battery positive (+) terminal and the black clip to the battery negative (–) terminal.

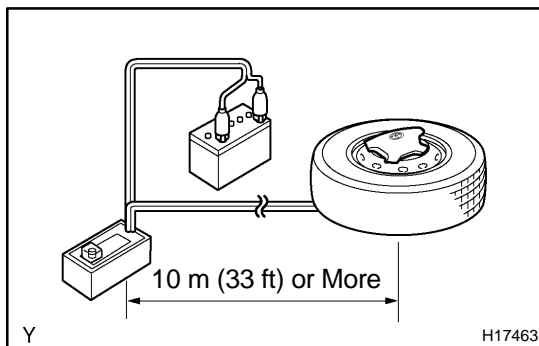

- (2) Check that no one is within 10 m (33 ft) area around the disc wheel which the steering wheel pad is tied to.
- (3) Press the SST activation switch and deploy the airbag.

**HINT:**

The airbag deploys simultaneously as the LED of the SST activation switch lights up.

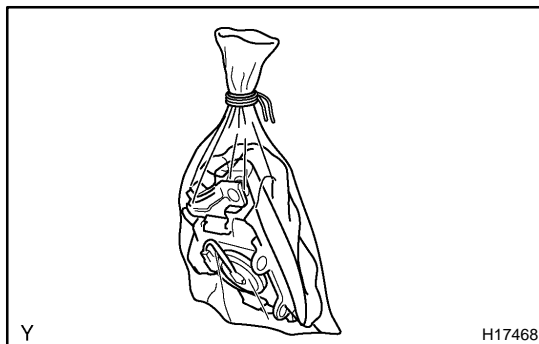

(g) Dispose of the steering wheel pad (with airbag).

**CAUTION:**

- **The steering wheel pad is very hot when the airbag is deployed, so leave it alone for at least 30 minutes after deployment.**
- **Use gloves and safety glasses when handling a steering wheel pad with the deployed airbag.**
- **Always wash your hands with water after completing the operation.**
- **Do not apply water, etc. to a steering wheel pad with the deployed airbag.**
  - (1) Remove the steering wheel pad from the disc wheel.
  - (2) Place the steering wheel pad in a vinyl bag, tie the end tightly and dispose of it in the same way as other general parts disposal.

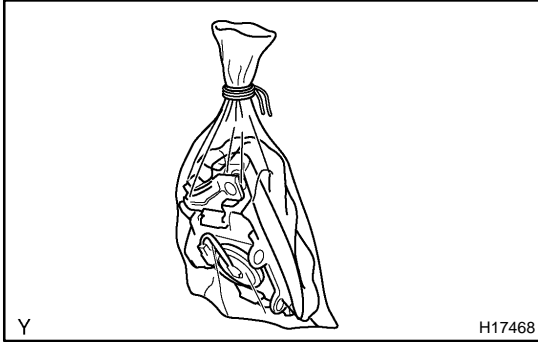

### 3. DEPLOYMENT WHEN DISPOSING OF STEERING WHEEL PAD WITH AIRBAG DEPLOYED IN COLLISION

Dispose of the steering wheel pad (with airbag).

#### CAUTION:

- The steering wheel pad is very hot when the airbag is deployed, so leave it alone for at least 30 minutes after deployment.
- When moving a vehicle for scrapping which has a steering wheel pad with the deployed airbag, use gloves and safety glasses.
- Use gloves and safety glasses when handling a steering wheel pad with deployed airbag.
- Always wash your hands with water after completing the operation.
- Do not apply water, etc. to a steering wheel pad with deployed airbag.
  - (1) Remove the steering wheel pad from the steering wheel (See page [SR-14](#)).
  - (2) Place the steering wheel pad in a vinyl bag, tie the end tightly and dispose of it in the same way as other general parts disposal.