

REPLACEMENT

1. IF NECESSARY, REPLACE COUNTER GEAR FRONT BEARING AND SIDE RACE

- (a) Using a snap ring expander, remove the snap ring.
- (b) Using SST and a press, press out the bearing.
SST 09950-00020
- (c) Check the side race for wear or damage.

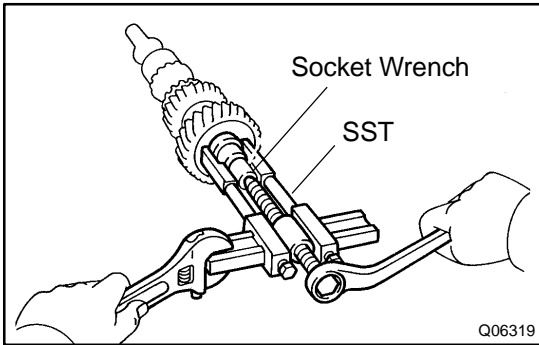

- (d) If necessary, remove the side race.
Using SST and a socket wrench, remove the side race.
SST 09950-40011

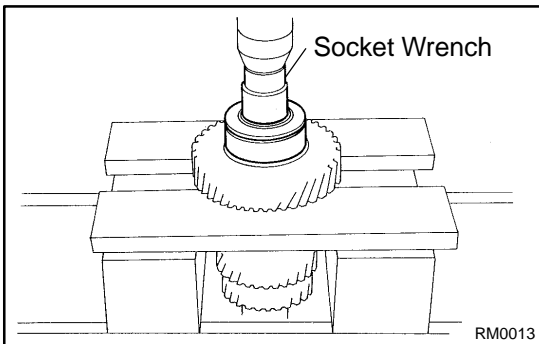

- (e) Using a socket wrench and press, install a new bearing, side race and inner race.

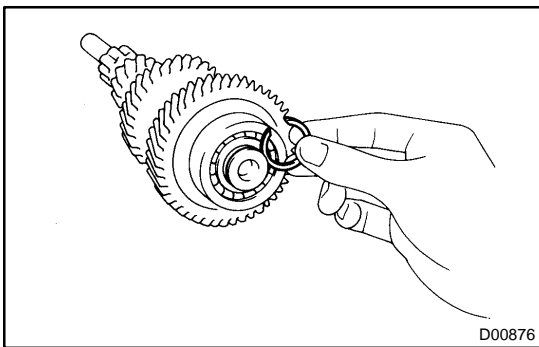

- (f) Select a snap ring that allows the minimum axial play.

Mark	Thickness mm (in.)
A	2.05 – 2.10 (0.0807 – 0.0827)
B	2.10 – 2.15 (0.0827 – 0.0846)
C	2.15 – 2.20 (0.0846 – 0.0866)
D	2.20 – 2.25 (0.0866 – 0.0886)
E	2.25 – 2.30 (0.0886 – 0.0906)
F	2.30 – 2.35 (0.0906 – 0.0925)

- (g) Using a snap ring expander, install the snap ring.

2. IF NECESSARY, REPLACE COUNTER GEAR CENTER BEARING

- (a) Remove the bearing from the counter gear.
- (b) Install a new bearing on the counter gear.

HINT:

Engage the roller cages.

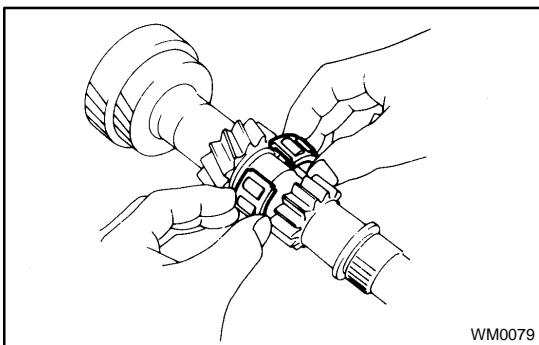

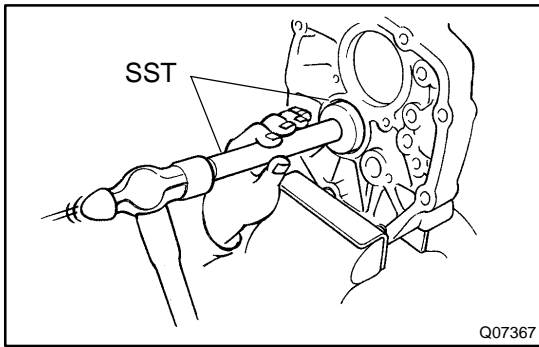

- (c) Using SST, tap out the bearing outer race.
SST 09950-60010 (09951-00510), 09950-70010
(09951-07150)

HINT:

After the outer race has been installed, the transmission is reassembled.