

INSTALLATION

1. INSTALL OIL PUMP

- (a) Remove any old packing (FIPG) material and be careful not to drop any oil on the contact surfaces of the oil pump and cylinder block.
- Using a razor blade and gasket scraper, remove all the old packing (FIPG) material from the gasket surfaces and sealing grooves.
 - Thoroughly clean all components to remove all the loose material.
 - Using a non-residue solvent, clean both sealing surfaces.

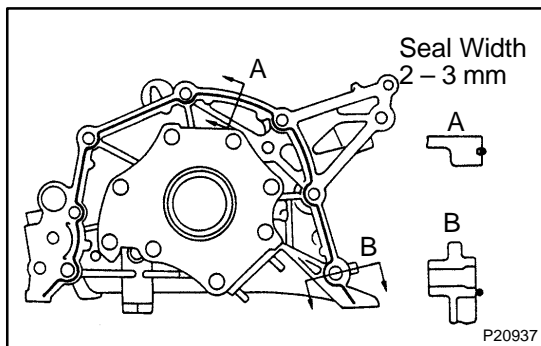

- (b) Apply seal packing to the oil pump, as shown in the illustration.

Seal packing: Part No. 08826-00080 or equivalent

- Install nozzle that has been cut out to a 2 – 3 mm (0.08 – 0.12 in.) opening.

HINT:

Avoid applying an excessive amount to the surface.

- Parts must be assembled within 5 minutes of application. Otherwise the material must be removed and reapplied.
- Immediately remove nozzle from the tube and reinstall cap.

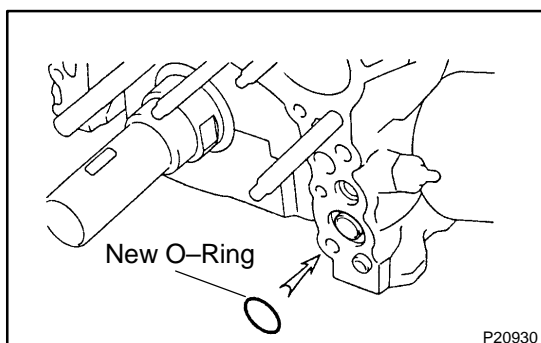

- (c) Place a new O-ring into the groove of the cylinder block.

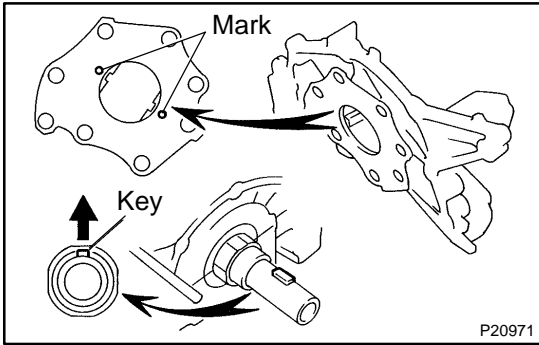

- (d) Install the oil pump to the crankshaft with the spline teeth of the drive rotor engaged with the large teeth of the crankshaft.

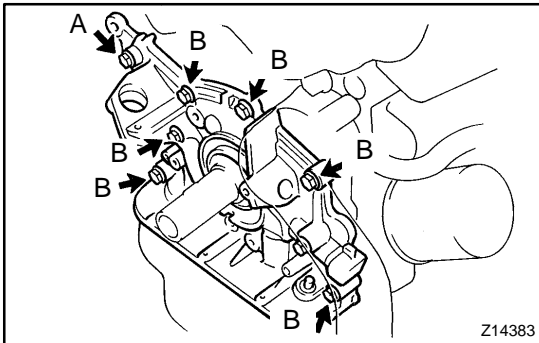

- (e) Install the oil pump and ground strap with the 8 bolts.

Torque:

Bolt A: 20 N-m (200 kgf-cm, 15 ft-lbf)

Bolt B: 42 N-m (420 kgf-cm, 31 ft-lbf)

2. **INSTALL CRANKSHAFT POSITION SENSOR**
3. **INSTALL OIL PAN BAFFLE PLATE**

Install the baffle plate with the bolt and 2 nuts.

Torque: 7.5 N-m (76 kgf-cm, 66 in.-lbf)

4. **INSTALL OIL STRAINER**

Install a new gasket and the oil strainer with the 2 bolts and 2 nuts.

Torque: 7.5 N-m (76 kgf-cm, 66 in.-lbf)

5. **INSTALL OIL PAN**

- (a) Remove any old packing (FIPG) material and be careful not to drop any oil on the contacting surfaces of the, oil pan, cylinder block and sealing grooves.

- (1) Using a razor blade and gasket scraper, remove all the remaining seal packing (FIPG) material from the gasket surfaces.
- (2) Thoroughly clean all components to remove all the loose material.
- (3) Clean both sealing surfaces with a non-residue solvent.

NOTICE:

Do not use a solvent which will affect the painted surfaces.

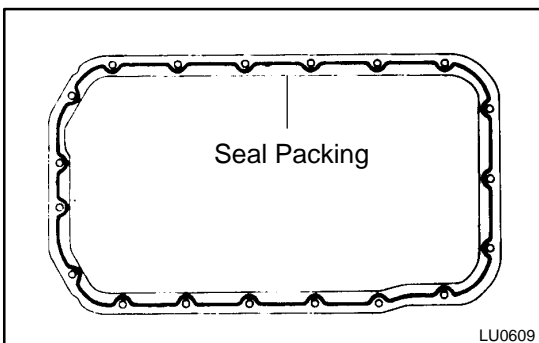

- (b) Apply seal packing to the oil pan as shown in the illustration.

Seal packing: Part No. 08826-00080 or equivalent

- (1) Install a nozzle that has been cut to a 3 – 4 mm (0.12 – 0.16 in.) opening.

HINT:

Avoid applying an excess amount to the surface.

- (2) If parts are not assembled within 5 minutes of applying the seal packing, the effectiveness of the seal packing is lost and the seal packing must be removed and reapplied.
- (3) Immediately remove the nozzle from the tube and reinstall the cap after using the seal packing.
- (c) Install the oil pan with the 4 nuts and 15 bolts.
Torque: 7.6 N·m (78 kgf·cm, 67 in.-lbf)
- 6. INSTALL FLYWHEEL HOUSING UNDER, COVER DUST AND STIFFENER PLATE**
- 7. CONNECT STARTER WIRE CLAMP**
- 8. A/T:
INSTALL OIL COOLER TUBE AND CLAMP
(A340E: See page [AT-27](#))
(A340F: See page [AT-36](#))**
- 9. INSTALL CRANKSHAFT TIMING PULLEY (See page [EM-19](#))**
- 10. 4WD:
INSTALL FRONT DIFFERENTIAL (See page [SA-65](#))**
- 11. FILL WITH ENGINE OIL**
- 12. START ENGINE AND CHECK FOR LEAKS**
- 13. INSTALL ENGINE UNDER COVER**
- 14. RECHECK ENGINE OIL LEVEL**