

REMOVAL

1. REMOVE ENGINE UNDER COVER
2. DRAIN ENGINE OIL
3. 4WD:
REMOVE FRONT DIFFERENTIAL AND DRIVE SHAFTS ASSEMBLY
4. REMOVE DRIVE BELT FOR GENERATOR, FAN WITH FLUID COUPLING AND WATER PUMP PULLEY (See page [CO-5](#))
5. REMOVE CYLINDER HEAD ASSEMBLY (See page [EM-34](#))

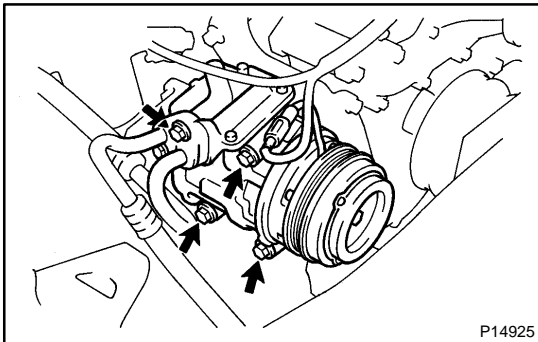

6. **DISCONNECT A/C COMPRESSOR AND BRACKET**
 - (a) Remove the 4 bolts, and disconnect the compressor from the bracket.

HINT:

Put aside the compressor, and suspend it.

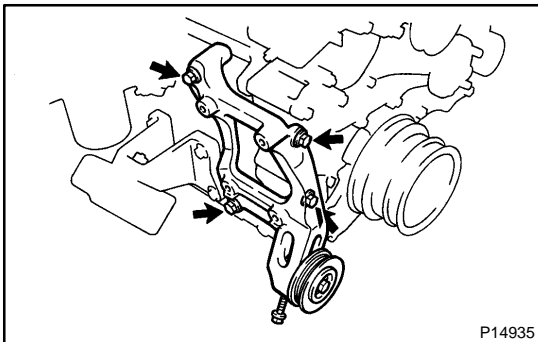

- (b) Remove the 4 bolts and A/C compressor bracket.

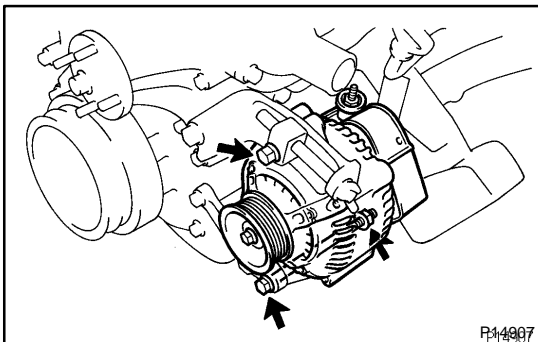

7. **REMOVE GENERATOR, ADJUSTING BAR AND BRACKET**
 - (a) Disconnect the generator connector.
 - (b) Remove the nut, and disconnect the generator wire and wire clip.
 - (c) Remove the lock bolt, pivot bolt and generator.

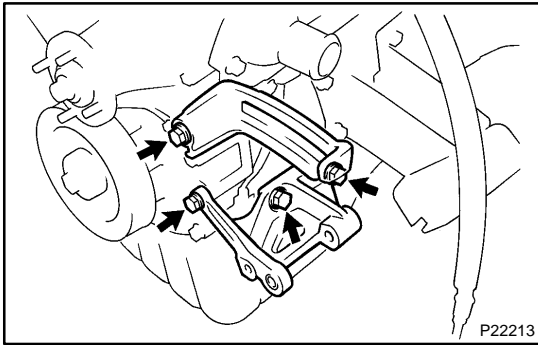

- (d) Remove the bolt and adjusting bar.
- (e) Remove the 3 bolts and generator bracket.

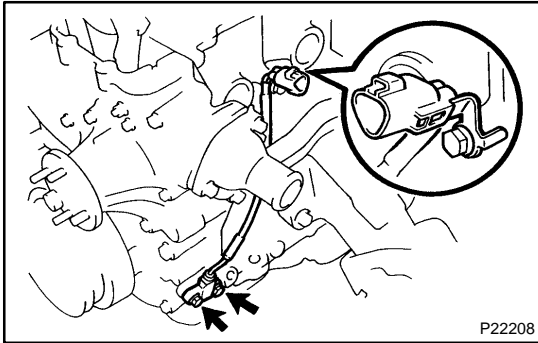

8. REMOVE CRANKSHAFT POSITION SENSOR

- (a) Remove the 2 bolts and crankshaft position sensor.
- (b) Remove the O-ring from the crankshaft position sensor.

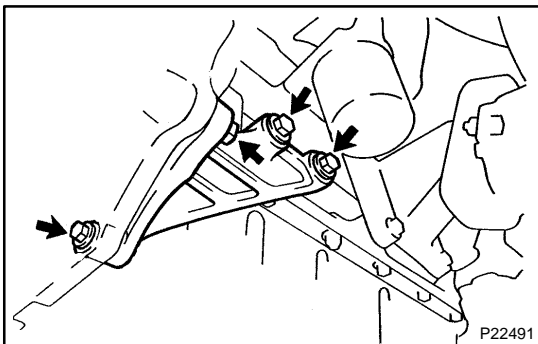

9. 2WD:

REMOVE STIFFENER PLATES

Remove the 8 bolts and stiffener plates.

10. REMOVE FLYWHEEL HOUSING UNDER COVER AND DUST SEAL

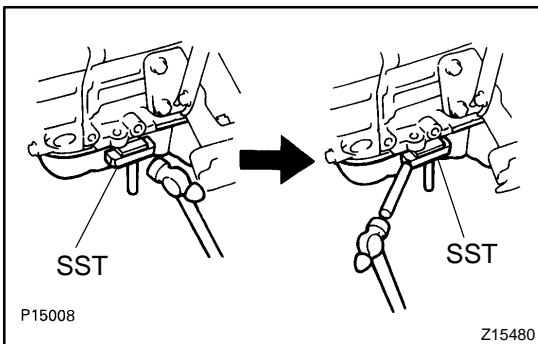

11. REMOVE OIL PAN

- (a) Remove the 16 bolts and 2 nuts.
- (b) Insert the blade of SST between the cylinder block and oil pan, cut off applied sealer and remove the oil pan.
SST 09032-00100

NOTICE:

Be careful not to damage the oil pan flanges of the oil pan and cylinder block.

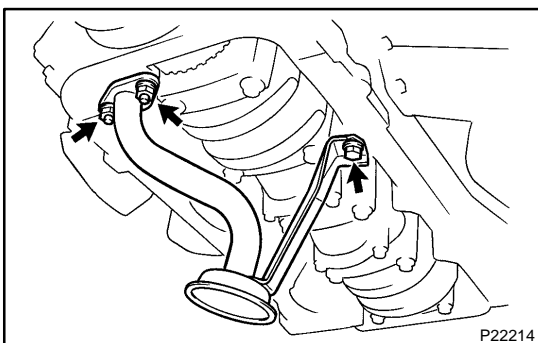

12. REMOVE OIL STRAINER

Remove the bolt, 2 nuts, oil strainer and gasket.

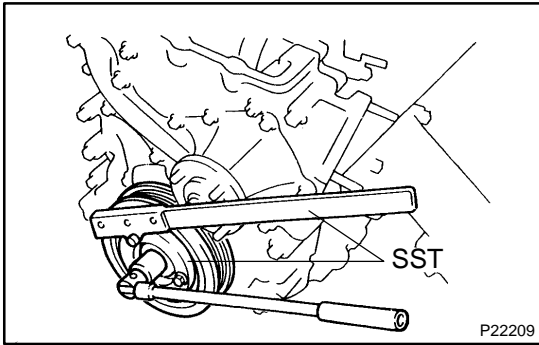

13. REMOVE CRANKSHAFT PULLEY

- (a) w/ A/C:
Remove the 4 bolts, No.2 and No.3 crankshaft pulleys.
- (b) Using SST, remove the pulley bolt.
SST 09213-54015, 09330-00021
- (c) Remove the crankshaft pulley.

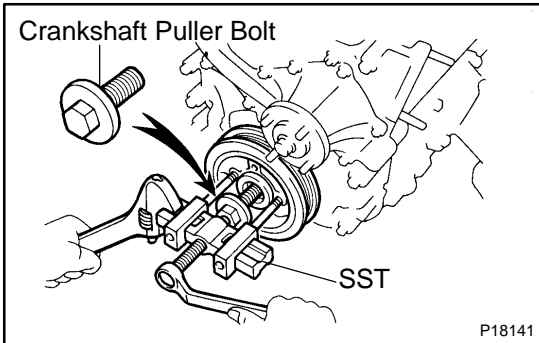

HINT:

If necessary, remove the pulley with SST and crankshaft pulley bolt.

SST 09950-50013 (09951-05010, 09952-05010, 09953-05010, 09954-05020)

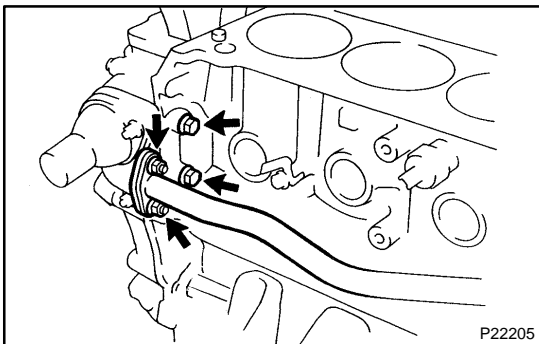

14. REMOVE TIMING CHAIN COVER

- (a) Remove the 2 water bypass pipe nuts.
- (b) Remove the 2 timing chain cover bolts.

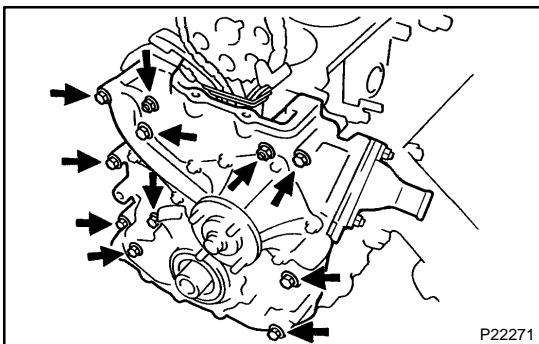

- (c) Remove the 9 bolts and 2 nuts.
- (d) Using a plastic faced hammer, loosen the chain cover and remove the timing chain cover and 3 gaskets.

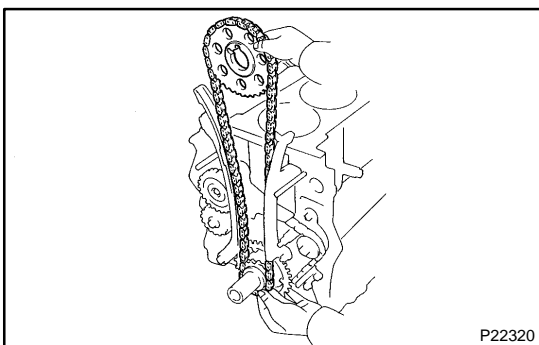

15. REMOVE NO.1 TIMING CHAIN AND CAMSHAFT TIMING SPROCKET

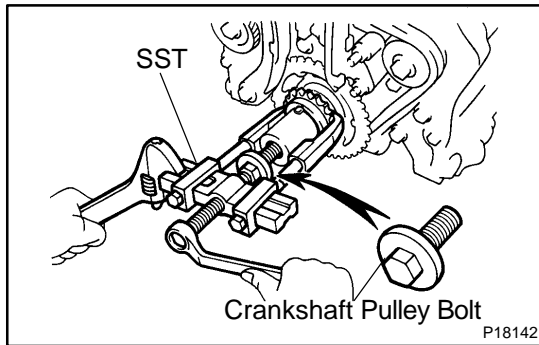
**16. REMOVE CRANKSHAFT TIMING SPROCKET****HINT:**

If necessary, remove the sprocket with SST and crankshaft pulley bolt.

SST 09950-40011 (09951-04010, 09952-04010, 09953-04010, 09954-04010, 09955-04061)

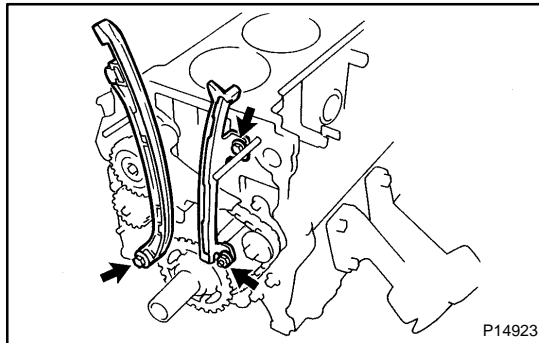
**17. REMOVE NO.1 TIMING CHAIN TENSIONER SLIPPER AND NO.1 VIBRATION DAMPER**

- (a) Remove the bolt and slipper.
- (b) 2RZ-FE:
Remove the 2 bolts and No.1 damper.
- (c) 3RZ-FE:
Remove the bolt, nut and No.1 damper.

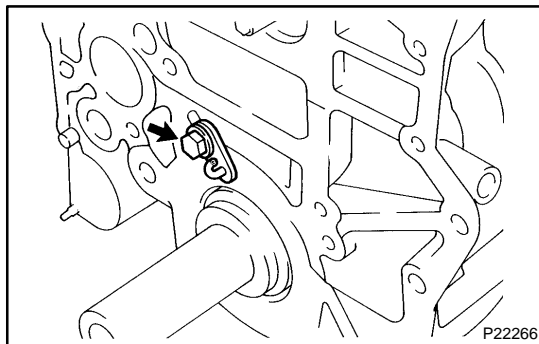
**18. 2RZ-FE:
REMOVE CRANKSHAFT POSITION SENSOR ROTOR****19. 2RZ-FE:
REMOVE TIMING CHAIN OIL JET**

Remove the bolt, oil jet and gasket.

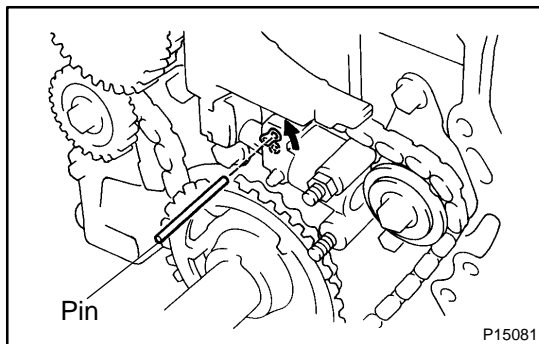
**20. 3RZ-FE:
REMOVE NO.2, NO.3 VIBRATION DAMPERS AND NO.2 CHAIN TENSIONER**

- (a) Install a pin to the No.2 chain tensioner and lock the plunger.

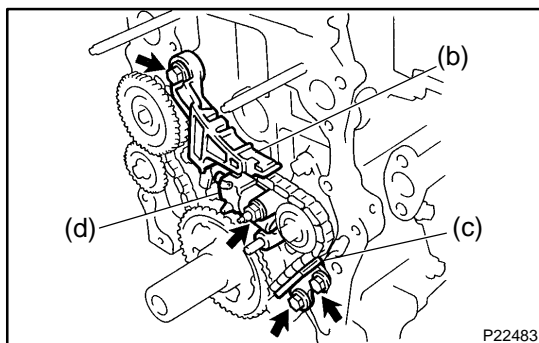

- (b) Remove the bolt and No.2 damper.
- (c) Remove the 2 bolts and No.3 damper.
- (d) Remove the nut and No.2 chain tensioner.

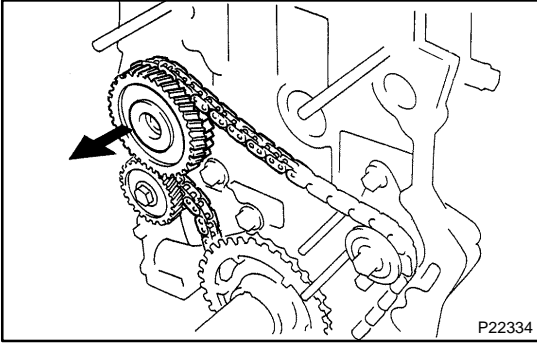

**21. 3RZ-FE:
REMOVE BALANCE SHAFT DRIVE GEAR, SHAFT,
NO.2 TIMING CHAIN AND NO.2 CRANKSHAFT TIM-
ING SPROCKET**

- (a) Remove the bolt from the balance shaft drive gear.
- (b) Remove the balance shaft drive gear with the shaft.
- (c) Remove the No.2 timing chain with the No.2 crankshaft timing sprocket.

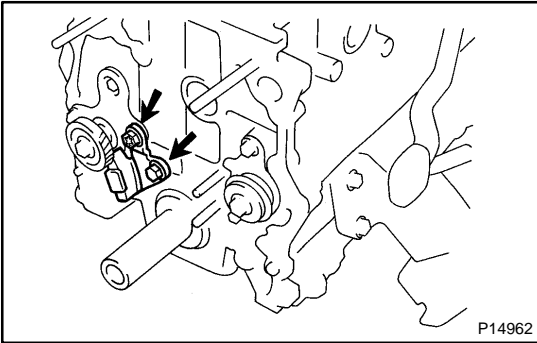

**22. 3RZ-FE:
REMOVE NO.4 VIBRATION DAMPER**

Remove the 2 bolts and No.4 damper.