

# EXHAUST SYSTEM COMPONENTS

EM1N1-02

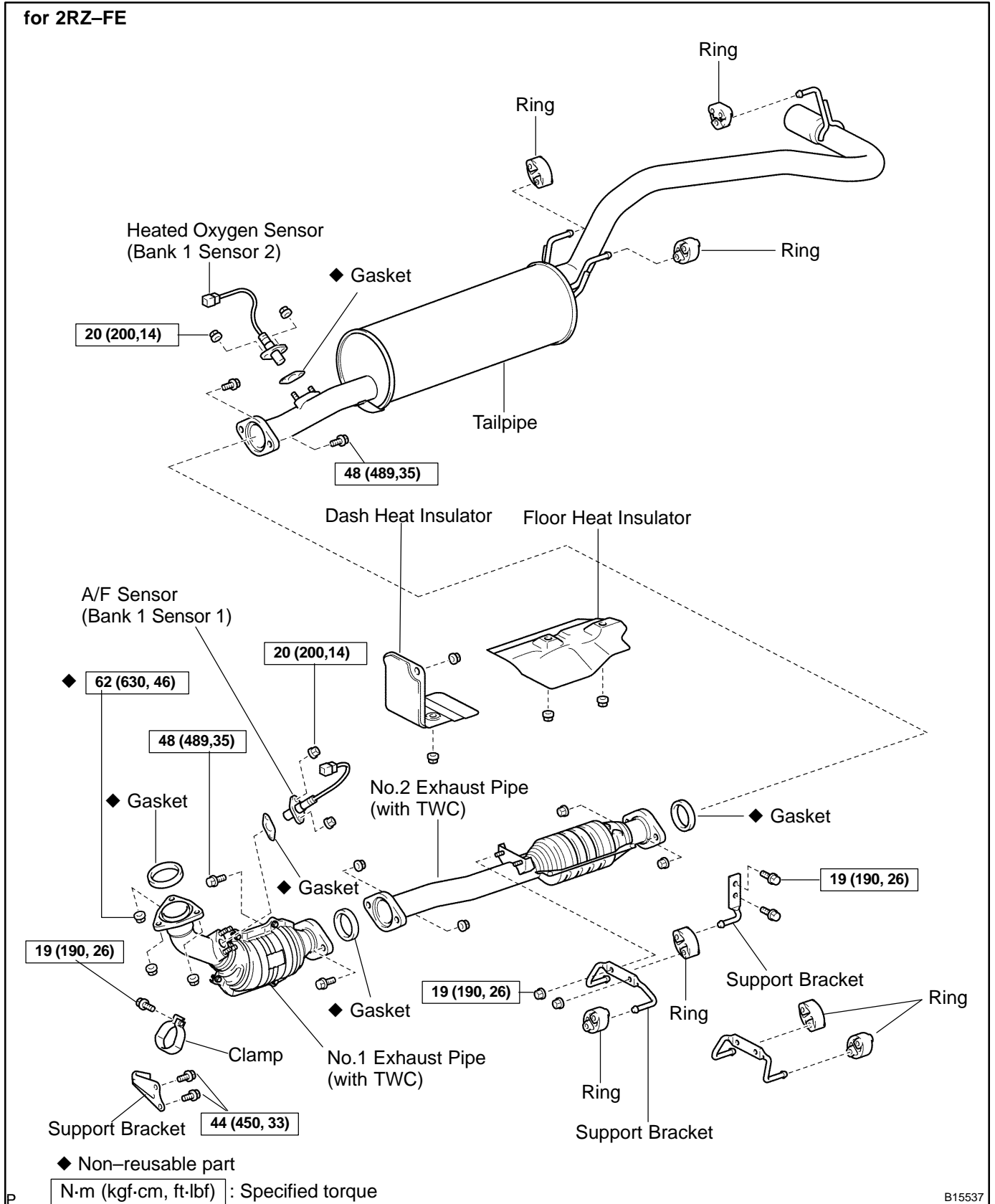

for 3RZ-FE

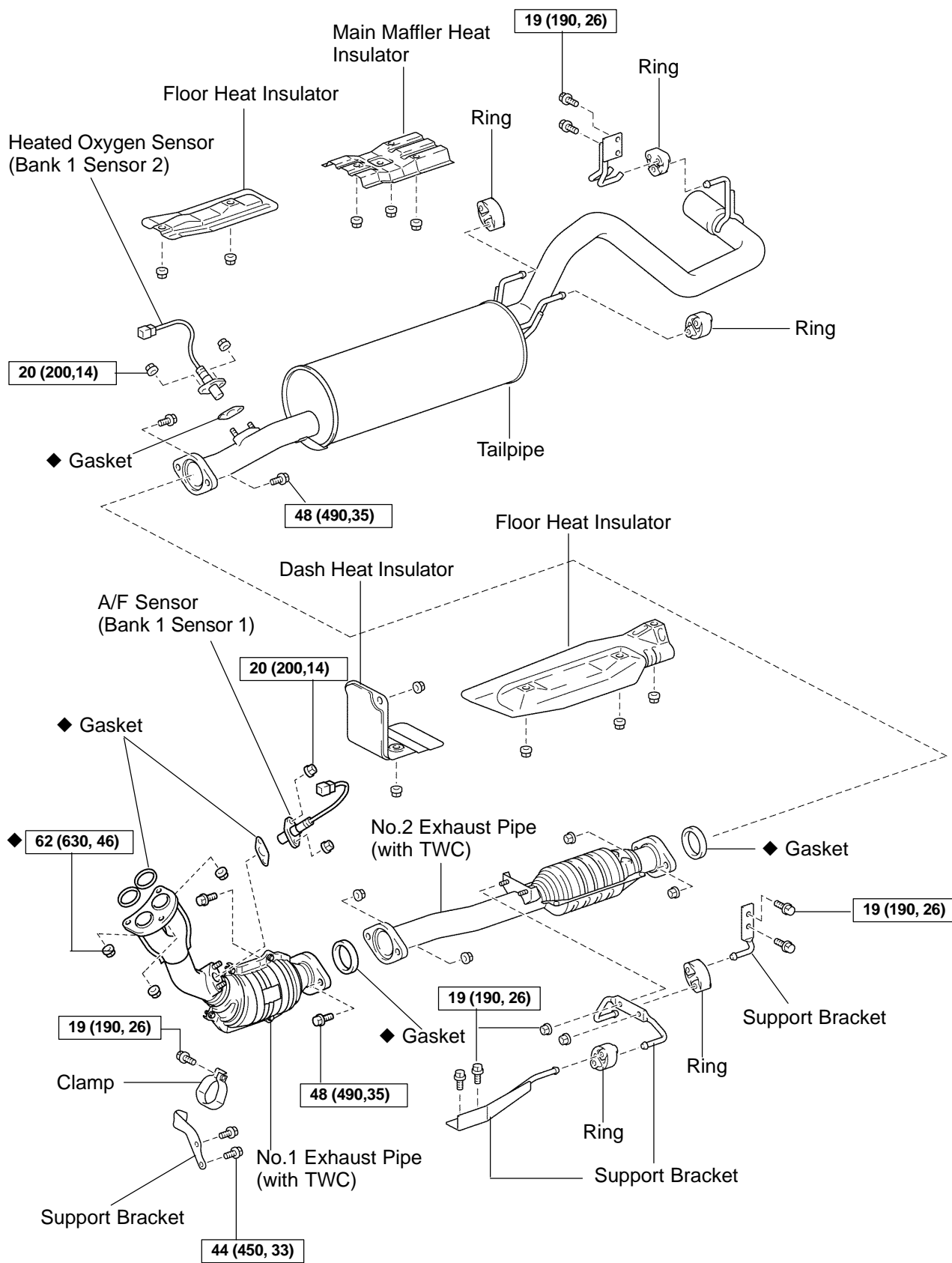

◆ Non-reusable part  
 [ ] N·m (kgf·cm, ft·lbf) : Specified torque

A17831