

<b>DTC</b>	<b>B0107/51</b>	<b>Short in P Squib Circuit (to Ground)</b>
------------	-----------------	---

**CIRCUIT DESCRIPTION**

The P squib circuit consists of the airbag sensor assembly and front passenger airbag assembly. It causes the SRS to deploy when the SRS deployment conditions are satisfied. For details of the function of each component, see OPERATION on page RS-2. DTC B0107/51 is recorded when ground short is detected in the P squib circuit.

DTC No.	DTC Detecting Condition	Trouble Area
B0107/51	<ul style="list-style-type: none"> <li>• Short circuit in P squib wire harness (to ground)</li> <li>• P squib malfunction</li> <li>• Airbag sensor assembly malfunction</li> </ul>	<ul style="list-style-type: none"> <li>• Front passenger airbag assembly (P squib)</li> <li>• Passenger airbag manual on-off switch</li> <li>• Airbag sensor assembly</li> <li>• Wire harness</li> </ul>

**WIRING DIAGRAM**

See page DI-616.

**INSPECTION PROCEDURE**

<b>1</b>	<b>Prepare for inspection (See step 1 on page DI-675).</b>
----------	--

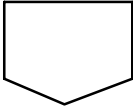

<b>2</b>	<b>Check passenger airbag manual on-off switch (See page RS-46).</b>
----------	--

<b>NG</b>	<b>Replace passenger airbag manual on-off switch.</b>
-----------	---

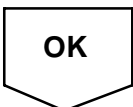

### 3 Check P squib circuit.

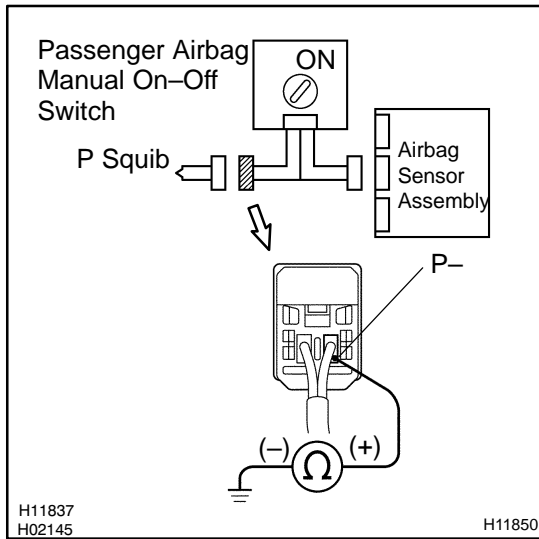

#### **PREPARATION:**

Turn the passenger airbag manual on-off switch to ON.

#### **CHECK:**

For the connector (on the front passenger airbag assembly side) between the front passenger airbag assembly and the airbag sensor assembly, measure the resistance between P+ and body ground.

#### **OK:**

**Resistance: 1 MΩ or Higher**

**NG**

**Repair or replace harness or connector between front passenger airbag assembly and airbag sensor assembly.**

**OK**

## 4 Check airbag sensor assembly.

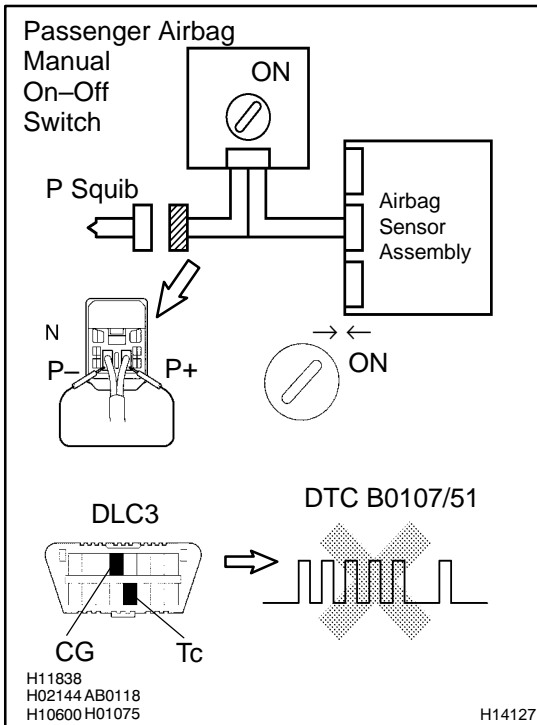

### PREPARATION:

- Turn the passenger airbag manual on-off switch to ON.
- Connect the connector to the airbag sensor assembly.
- Using a service wire, connect P+ and P- of the connector (on the front passenger airbag assembly side) between the front passenger airbag assembly and the airbag sensor assembly.
- Connect negative (-) terminal cable to the battery, and wait at least for 2 seconds.

### CHECK:

- Turn the ignition switch to ON and wait at least for 20 seconds.
- Clear the DTC stored in memory (See step 5 on page [DI-588](#)).
- Turn the ignition switch to LOCK, and wait at least for 20 seconds.
- Turn the ignition switch to ON, and wait at least for 20 seconds.
- Check the DTC (See page [DI-588](#)).

### OK:

**DTC B0107/51 is not output.**

### HINT:

Codes other than code B0107/51 may be output at this time, but they are not relevant to this check.

**NG**

**Replace airbag sensor assembly.**

**OK**

## 5 Check P squib.

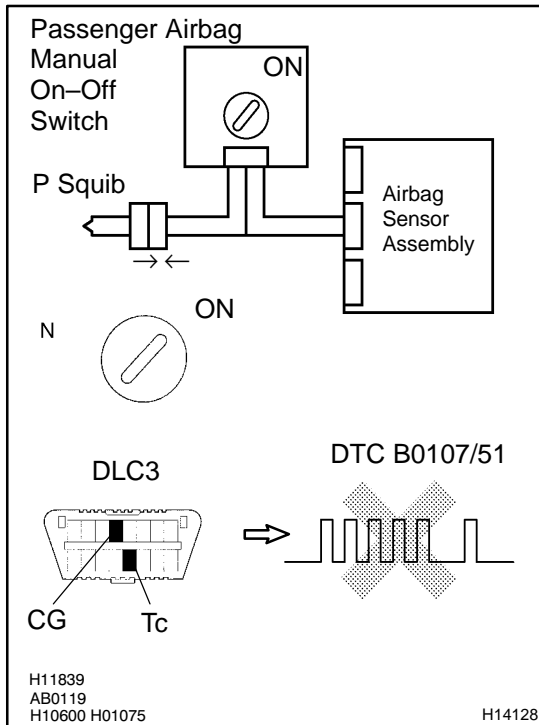

### PREPARATION:

- Turn the passenger airbag manual on-off switch to ON.
- Turn the ignition switch to LOCK.
- Disconnect negative (-) terminal cable from the battery, and wait at least for 90 seconds.
- Connect the front passenger airbag assembly connector.
- Connect negative (-) terminal cable to the battery, and wait at least for 2 seconds.

### CHECK:

- Turn the ignition switch to ON, and wait at least for 20 seconds.
- Clear the DTC stored in memory (See step 5 on page [DI-588](#)).
- Turn the ignition switch to LOCK, and wait at least for 20 seconds.
- Turn the ignition switch to ON, and wait at least for 20 seconds.
- Check the DTC (See page [DI-588](#)).

### OK:

**DTC B0107/51 is not output.**

### HINT:

Codes other than code B0107/51 may be output at this time, but they are not relevant to this check.

**NG**

**Replace front passenger airbag assembly.**

**OK**

**From the results of the above inspection, the malfunctioning part can now be considered normal. To make sure of this, use the simulation method to check. If the malfunctioning part can not be detected by the simulation method, replace all SRS components including the wire harness.**