

DISASSEMBLY

1. REMOVE RESERVOIR TANK

- (a) Using a pin punch and hammer, drive out the slotted spring pin.
- (b) Remove the reservoir tank and grommet.

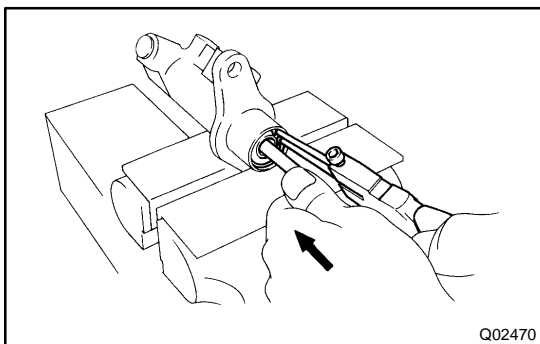

2. REMOVE PUSH ROD

Pull back the boot, and using snap ring pliers, remove the snap ring.

3. REMOVE PISTON