

AIR CONDITIONING

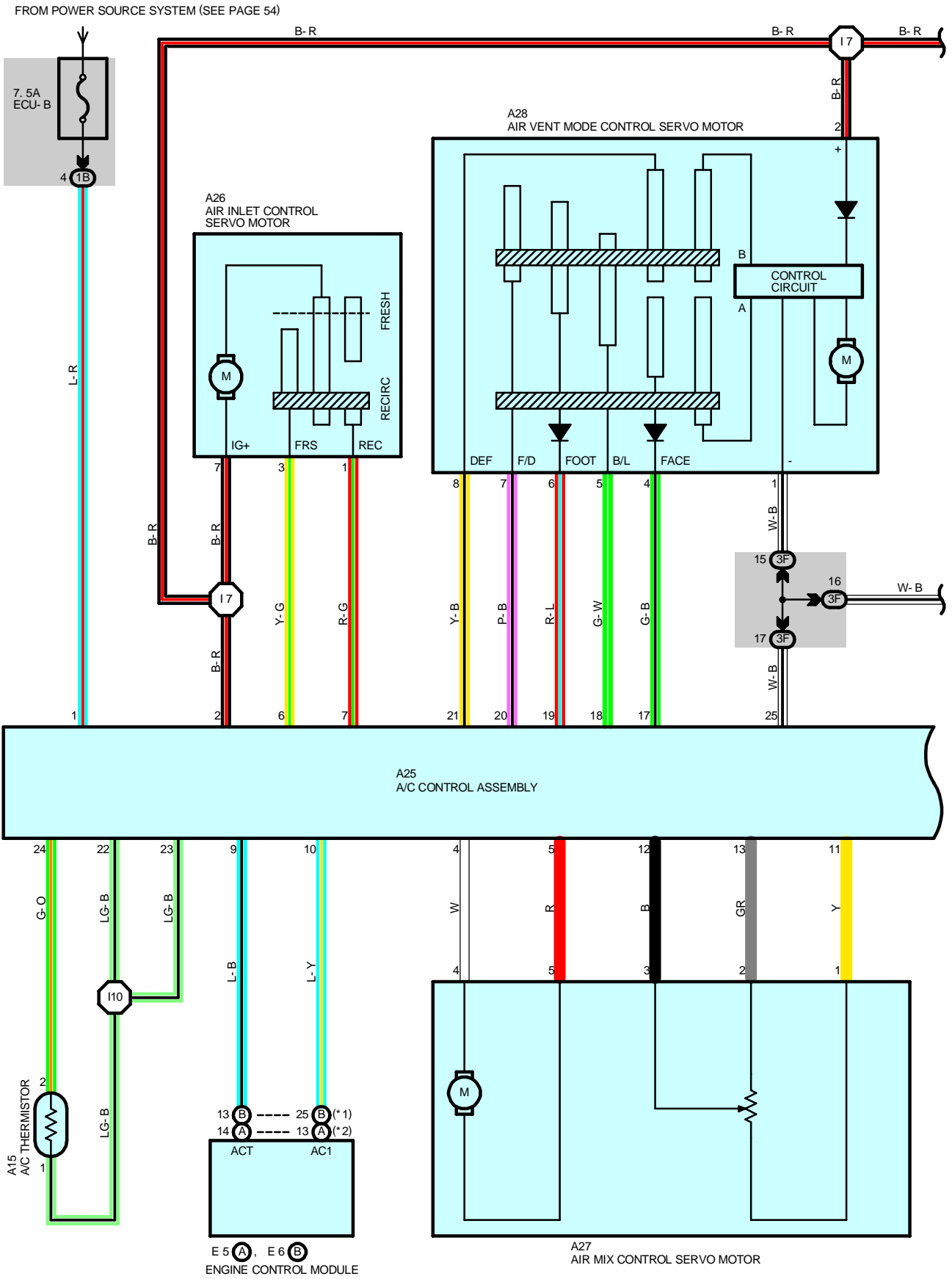

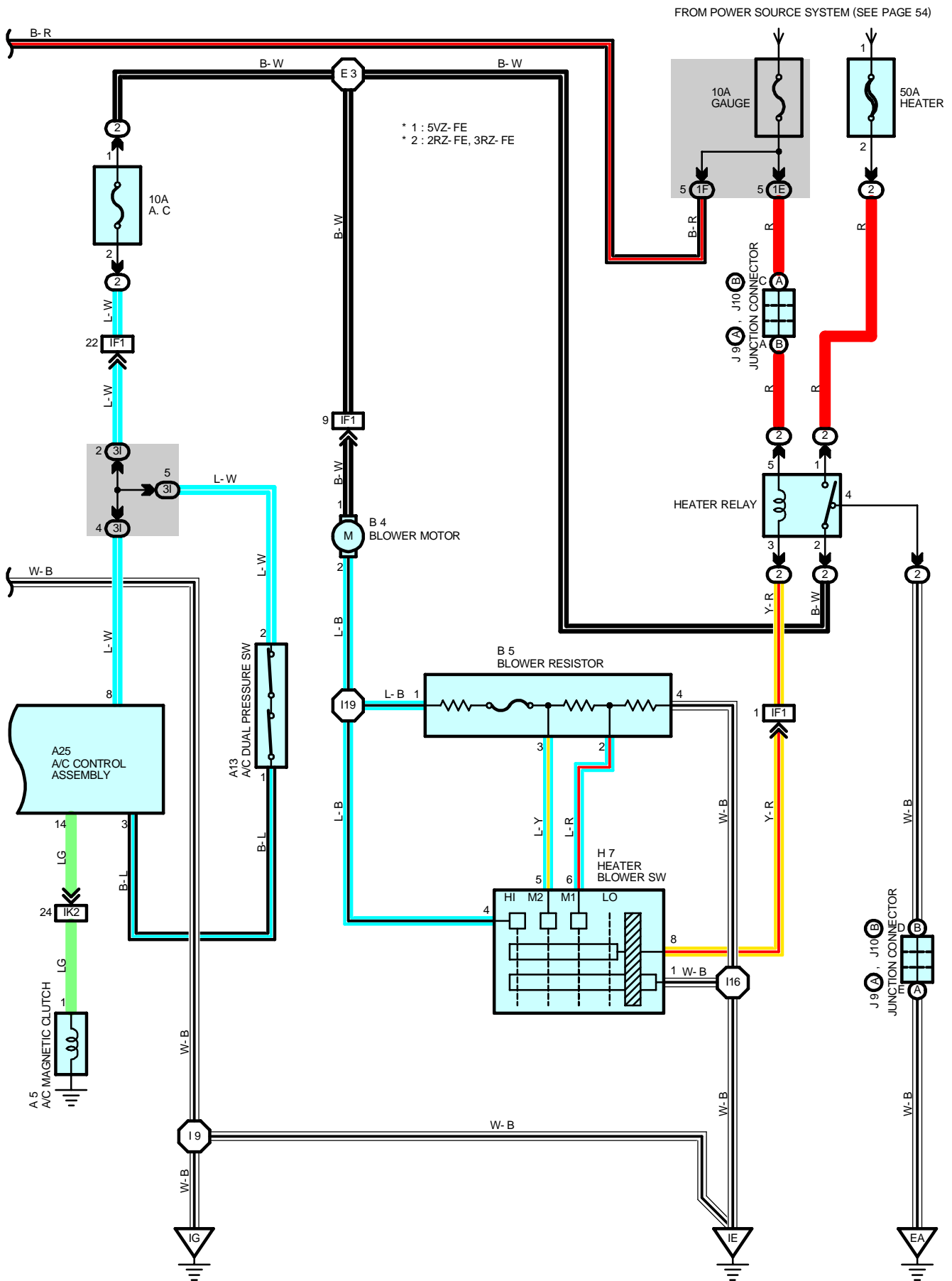

AIR CONDITIONING

SYSTEM OUTLINE

1. HEATER BLOWER MOTOR OPERATION

With the ignition SW on, the current from the GAUGE fuse flows to TERMINAL 5 of the HEATER relay to TERMINAL 3 to TERMINAL 8 of the heater blower SW.

(Low speed operation)

When the heater blower SW is moved to the low speed position, the current applied to TERMINAL 8 of the heater blower SW flows from TERMINAL 1 to GROUND, causing the HEATER relay to come on. Then the current flowing from the HEATER fuse flows to TERMINAL 1 of the HEATER relay to TERMINAL 2 to TERMINAL 1 of the blower motor to TERMINAL 2 to TERMINAL 1 of the blower resistor to TERMINAL 4 to GROUND, causing the blower motor to rotate.

At this time, current flows against the full resistance of the blower resistor, so the motor rotates slowly at low speed.

(Operation at speed M1, M2)

When the heater blower SW is moved to the speed M1 position, the current applied to TERMINAL 8 of the heater blower SW flows to TERMINAL 1 to GROUND, turning the HEATER relay to on. Then, the same as with low speed, current passes from the blower motor to TERMINAL 1 of the blower resistor to TERMINAL 2 to TERMINAL 6 of the heater blower SW to TERMINAL 1 to GROUND. At this time, the resistance of the blower resistor is less than it is for low speed, so the blower motor rotates faster than it does at low speed. With the heater blower SW in the M2 position, current flowing through the motor flows from TERMINAL 1 of the blower resistor to TERMINAL 3 to TERMINAL 5 of the heater blower SW to TERMINAL 1 to GROUND. At this time, the resistance of the blower resistor is less than for speed M1, so the blower motor rotates faster than for speed M1.

(High speed operation)

With the heater blower SW in high speed position, until the HEATER relay comes on and current flows to the blower motor, operation is the same as for speed M1 and M2. The current passing through the blower motor flows to TERMINAL 4 of the heater blower SW to TERMINAL 1 to GROUND without flowing through the blower resistor, so that the blower motor rotates at the fastest speed, high speed.

2. AIR INLET CONTROL SERVO MOTOR OPERATION

(Switching from FRESH to RECIRC)

With the ignition SW turned on, the current flows from GAUGE fuse to TERMINAL 7 of the air inlet control servo motor to TERMINAL 3 to TERMINAL 6 of the A/C control assembly to TERMINAL 25 to GROUND, the motor rotates and the damper moves to the RECIRC side. When the damper operates with the A/C SW at RECIRC position, the damper position signal is input from TERMINAL 1 of the servo motor to TERMINAL 7 of the A/C control assembly. As a result, current to the servo motor circuit is cut off by the A/C control assembly, so the damper stops at that position.

(Switching from RECIRC to FRESH)

With the ignition SW turned on, when the RECIRC/FRESH SW is switched to the FRESH side, the current flows from TERMINAL 7 of the air inlet control servo motor to TERMINAL 3 to TERMINAL 6 of the A/C control assembly to TERMINAL 25 to GROUND, the motor rotates and the damper stops at that position.

3. AIR VENT MODE CONTROL SERVO MOTOR OPERATION

When the ignition SW turned on, the current flows from GAUGE fuse to TERMINAL 2 of the A/C control assembly.

(Switching from DEF to FACE)

The current flows from TERMINAL 17 of the A/C control assembly to TERMINAL 4 of the air vent mode control servo motor to TERMINAL 8 to TERMINAL 21 of the A/C control assembly to TERMINAL 25 to GROUND. The motor rotates and the damper moves to the FACE side. When the damper operates with the A/C SW at FACE position, the damper position signal is input from TERMINAL 8 of the servo motor to the TERMINAL 21 of the A/C control assembly. As a result, current to the servo motor circuit is cut off by the A/C control assembly, so the damper stops at that position.

(Switching from FACE to DEF)

The current flows from TERMINAL 21 of the A/C control assembly to TERMINAL 8 of the air vent control servo motor to TERMINAL 4 to TERMINAL 17 of the A/C control assembly to TERMINAL 25 to GROUND, the motor rotates and the damper stops at that position.

4. AIR MIX CONTROL SERVO MOTOR CONTROL

When the temperature control SW is pressed, the A/C control assembly sends a signal to the air mix control servo motor. This signal drives the motor to reach the temperature set by the temperature control SW, and moves the film damper.

5. AIR CONDITIONING OPERATION

When the blower SW is set to on, current from the HEATER fuse flows through the HEATER relay (Point side) to A.C fuse to TERMINAL 2 of the A/C dual pressure SW to TERMINAL 1 to TERMINAL 3 of the A/C control assembly. The evaporator temp. signal from the A/C thermistor are all supplied to the A/C control assembly. When the A/C SW is turned on, the A/C SW on signal is sent to activate the A/C control assembly. Current flows from the A/C control assembly to the magnetic clutch, turning the compressor on. The A/C operation is shut off when a signal indicating low evaporator temp., or abnormally high or low refrigerant pressure, is supplied while the engine high speed signal exists. When one of these signals is received, the assembly shuts off the A/C operation.

SERVICE HINTS

HEATER RELAY

1-2 : Closed with ignition SW on and blower SW on.

A13 A/C DUAL PRESSURE SW

1-2 : Open with refrigerant pressure at less than approx. **2.0 kgf/cm² (28.4 psi, 196 kpa)** or more than approx. **32 kgf/cm² (455 psi, 3138 kpa)**.

○ : PARTS LOCATION

Code	See Page	Code	See Page	Code	See Page
A5	30 (5VZ-FE) 32 (3RZ-FE, 2RZ-FE)	A27	34	H7	35
A13	34	A28	34	J9	A 31 (5VZ-FE) 33 (3RZ-FE, 2RZ-FE)
A15	34	B4	34	J10	B 31 (5VZ-FE) 33 (3RZ-FE, 2RZ-FE)
A25	34	B5	34		
A26	34	E5	A 35		
		E6	B 35		

○ : RELAY BLOCKS

Code	See Page	Relay Blocks (Relay Block Location)
2	21	R/B No.2 (Engine Compartment Left)

○ : JUNCTION BLOCK AND WIRE HARNESS CONNECTOR

Code	See Page	Junction Block and Wire Harness (Connector Location)
1B	23	Cowl Wire and J/B No.1 (Lower Finish Panel)
1E	23	Engine Room Main Wire and J/B No.1 (Lower Finish Panel)
1F	23	Cowl Wire and J/B No.1 (Lower Finish Panel)
3F	24	Cowl Wire and J/B No.3 (Behind the Instrument Panel Left)
3I	26	Cowl Wire and J/B No.3 (Behind the Instrument Panel Center)

□ : CONNECTOR JOINING WIRE HARNESS AND WIRE HARNESS

Code	See Page	Joining Wire Harness and Wire Harness (Connector Location)
IF1	44	Engine Room Main Wire and Cowl Wire (Left Kick Panel)
IK2	44	Engine Wire and Cowl Wire (Above the Glove Box)

▽ : GROUND POINTS

Code	See Page	Ground Points Location
EA	40 (5VZ-FE) 42 (3RZ-FE, 2RZ-FE)	Front Left Fender
IE	44	Around the Right Edge of the Reinforcement
IG	44	Around the Left Edge of the Reinforcement

○ : SPLICE POINTS

Code	See Page	Wire Harness with Splice Points	Code	See Page	Wire Harness with Splice Points
E3	40 (5VZ-FE)	Engine Room Main Wire	I10	44	Cowl Wire
	42 (3RZ-FE, 2RZ-FE)		I16		
I7	44	Cowl Wire	I19		
I9					