

ELECTRONICALLY CONTROLLED TRANSMISSION (3RZ-FE)

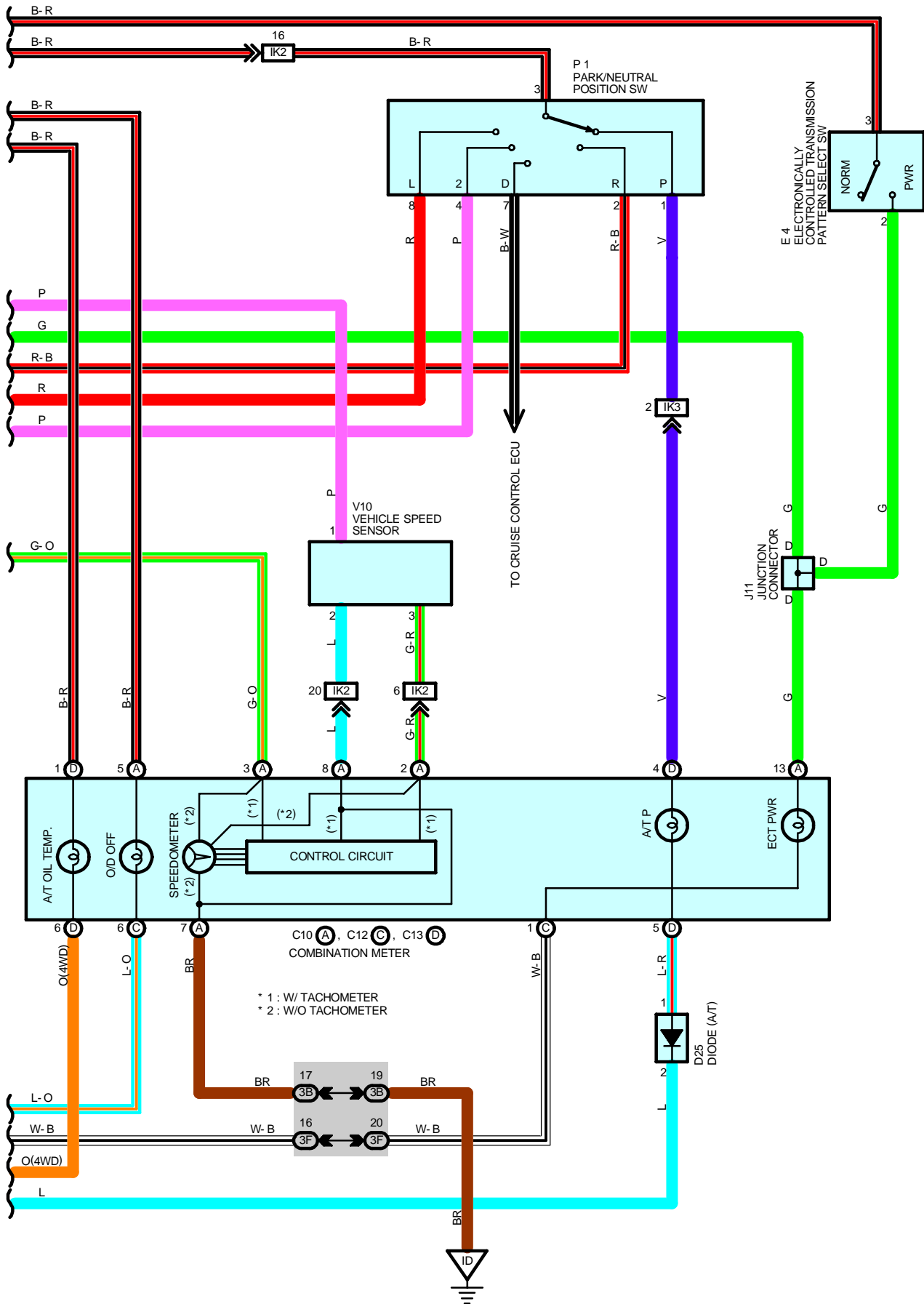

SYSTEM OUTLINE

Previous automatic transmissions have selected each gear shift using mechanically controlled throttle hydraulic pressure, governor hydraulic pressure and lock-up hydraulic pressure. The electronically controlled transmission, however, electrically controls the governor pressure and lock-up pressure through the solenoid valve. Control of the solenoid valve by the engine control module based on the input signals from each sensor makes smooth driving possible by shift selection for each gear which is most appropriate to the driving conditions at that time.

1. GEAR SHIFT OPERATION

During driving, the engine control module selects the shift for each gear which is most appropriate to the driving conditions, based on input signals from the engine coolant temp. sensor to TERMINAL THW of the engine control module, and also the input signals to TERMINAL SP2+ of the engine control module from the vehicle speed sensor devoted to the electronically controlled transmission. Current is then output to the electronically controlled transmission solenoid. When shifting to 1st speed, current flows from TERMINAL S1 of the engine control module to TERMINAL 1 of the electronically controlled transmission solenoid to GROUND, and continuity to the No.1 solenoid causes the shift.

For 2nd speed, current flows from TERMINAL S1 of the engine control module to TERMINAL 1 of the electronically controlled transmission solenoid to GROUND, and from TERMINAL S2 of the engine control module to TERMINAL 2 of the electronically controlled transmission solenoid to GROUND, and continuity to solenoid No.1 and No.2 causes the shift.

For 3rd speed, there is no continuity to No.1 solenoid, only to No.2 causing the shift. Shifting into 4th speed (Overdrive) takes place when there is no continuity to either No.1 or No.2 solenoid.

2. LOCK-UP OPERATION

When the engine control module judges from each signal that lock-up operation conditions have been met, current flows from TERMINAL SL of the engine control module to TERMINAL 3 of the electronically controlled transmission solenoid to GROUND, causing continuity to the lock-up solenoid and causing lock-up operation.

3. STOP LIGHT SW CIRCUIT

If the brake pedal is depressed (Stop light SW on) when driving in lock-up condition, a signal is input to TERMINAL STP of the engine control module, the engine control module operates and continuity to the lock-up solenoid is cut.

4. OVERDRIVE CIRCUIT

* O/D main SW on

When the O/D main SW is turned on, a signal is input to TERMINAL ODMS of the engine control module and engine control module operation causes gear shift when the conditions for overdrive are met.

* O/D main SW off

When the O/D main SW is turned off, a signal is input into TERMINAL ODMS of the engine control module, and turns on the O/D off indicator light. This activates the ECU, and the transmission system is controlled not to shift to overdrive.

ELECTRONICALLY CONTROLLED TRANSMISSION (3RZ-FE)

SERVICE HINTS

E2 ELECTRONICALLY CONTROLLED TRANSMISSION SOLENOID

1, 2, 3-GROUND : Approx. 13 Ω

P1 PARK/NEUTRAL POSITION SW

3-GROUND : Approx. 12 volts with ignition SW **ON** position

S5 STOP LIGHT SW

2-1 : Closed with brake pedal depressed

E5 (A), E6 (B), E7 (C), E8 (D) ENGINE CONTROL MODULE

S1-E1 : 9- 14 volts

S2, SL-E1 : 0- 1.5 volts

STP-E1 : 7.5- 14 volts with brake pedal depressed
: 0- 1.5 volts with brake pedal released

THW-E2 : 0.2- 1.0 volts with coolant temp. 80°C (176°F)

THO-E2 : 4- 5 volts with fluid temp. 20°C (68°F)

VTA-E2 : 0.3- 0.8 volts with throttle valve fully closed
: 3.2- 4.9 volts with throttle valve fully open

VC-E2 : 4.5- 5.5 volts

OD1-E1 : 4.5- 5.5 volts

SP1-E1 : Pulse generation with vehicle moving

2-E1 : 10- 14 volts with shift lever at **2** position
: 0- 2 volts with shift lever at except **2** position

L-E1 : 10- 14 volts with shift lever at **L** position
: 0- 2 volts with shift lever at except **L** position

R-E1 : 10- 4 volts with shift lever at **R** position
: 0- 2 volts with shift lever at except **R** position

PWR-E1 : 7.5- 14 volts with pattern select SW **PWR** position
: 0- 1.5 volts with pattern select SW **NORM** position

+B-E1 : 9- 14 volts

BATT-E1 : 9- 14 volts

○ : PARTS LOCATION

Code	See Page	Code	See Page	Code	See Page
A7	32 (3RZ-FE)	E3	32 (3RZ-FE)	J11	35
C10	A 34	E4	35	J13	35
C12	C 34	E5	A 35	P1	33 (3RZ-FE)
C13	D 34	E6	B 35	S4	35
C17	34	E7	C 35	S5	35
D7	34	E8	D 35	T1	33 (3RZ-FE)
D25	34	J9	A 33 (3RZ-FE)	V1	33 (3RZ-FE)
E2	32 (3RZ-FE)	J10	B 33 (3RZ-FE)	V10	33 (3RZ-FE)

○ : RELAY BLOCKS

Code	See Page	Relay Blocks (Relay Block Location)
2	21	R/B No.2 (Engine Compartment Left)

○ : JUNCTION BLOCK AND WIRE HARNESS CONNECTOR

Code	See Page	Junction Block and Wire Harness (Connector Location)
1F	23	Cowl Wire and J/B No.1 (Lower Finish Panel)
3B	24	Cowl Wire and J/B No.3 (Behind the Instrument Panel Left)
3D		
3E		
3F		
3G	26	Cowl Wire and J/B No.3 (Behind the Instrument Panel Center)

 : CONNECTOR JOINING WIRE HARNESS AND WIRE HARNESS

Code	See Page	Joining Wire Harness and Wire Harness (Connector Location)
IF1	44	Engine Room Main Wire and Cowl Wire (Left Kick Panel)
IK2	44	Engine Wire and Cowl Wire (Above the Glove Box)
IK3		

 : GROUND POINTS

Code	See Page	Ground Points Location
EA	42 (3RZ-FE)	Front Left Fender
EF	42 (3RZ-FE)	Ignition Coil Braket
ID	44	Left Kick Panel
IE	44	Around the Right Edge of the Reinforcement
IG	44	Around the Left Edge of the Reinforcement

 : SPLICE POINTS

Code	See Page	Wire Harness with Splice Points	Code	See Page	Wire Harness with Splice Points
I9	44	Cowl Wire	I13	44	Engine Wire
I12					