

# ENGINE CONTROL (5VZ-FE)

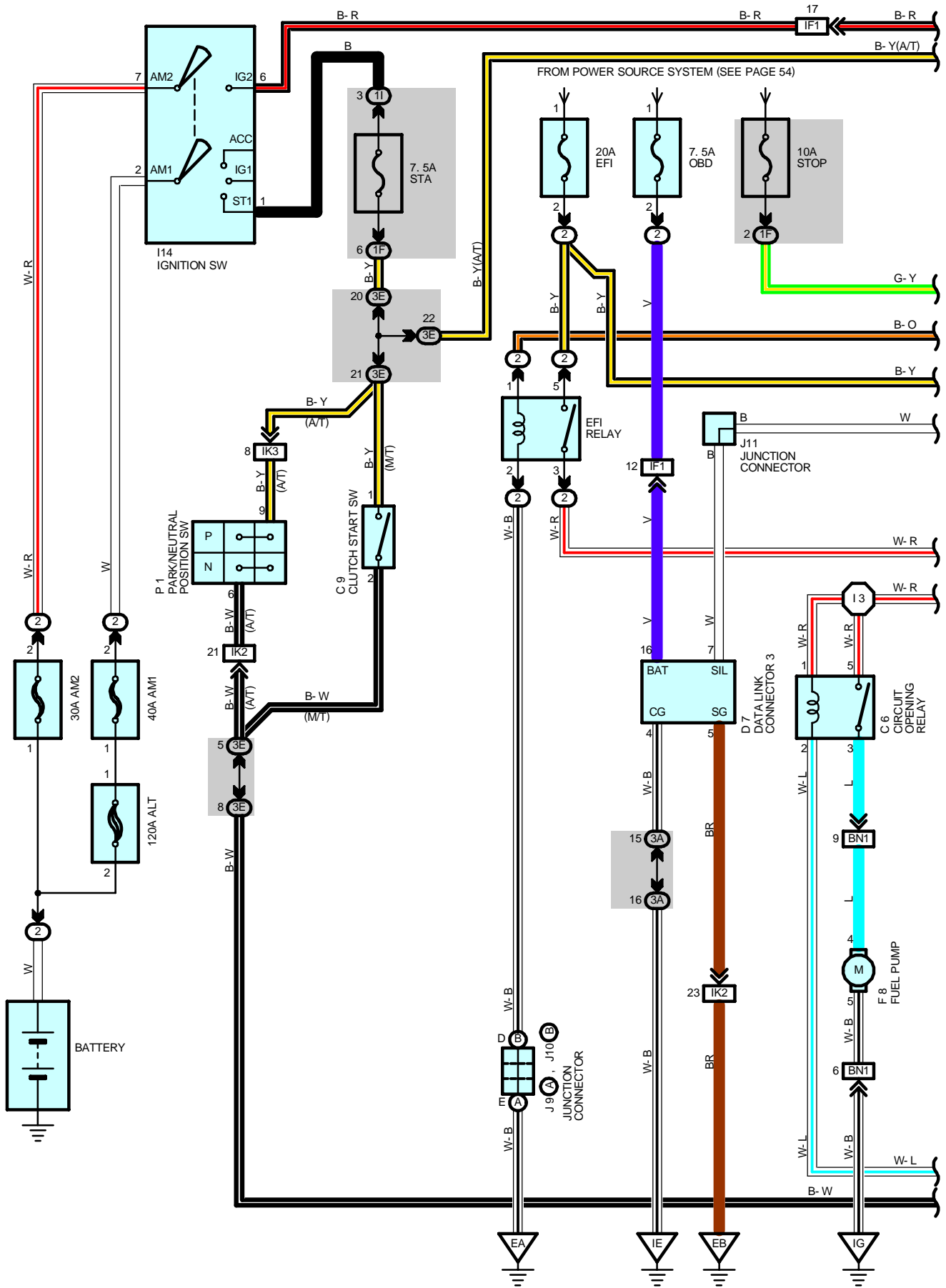

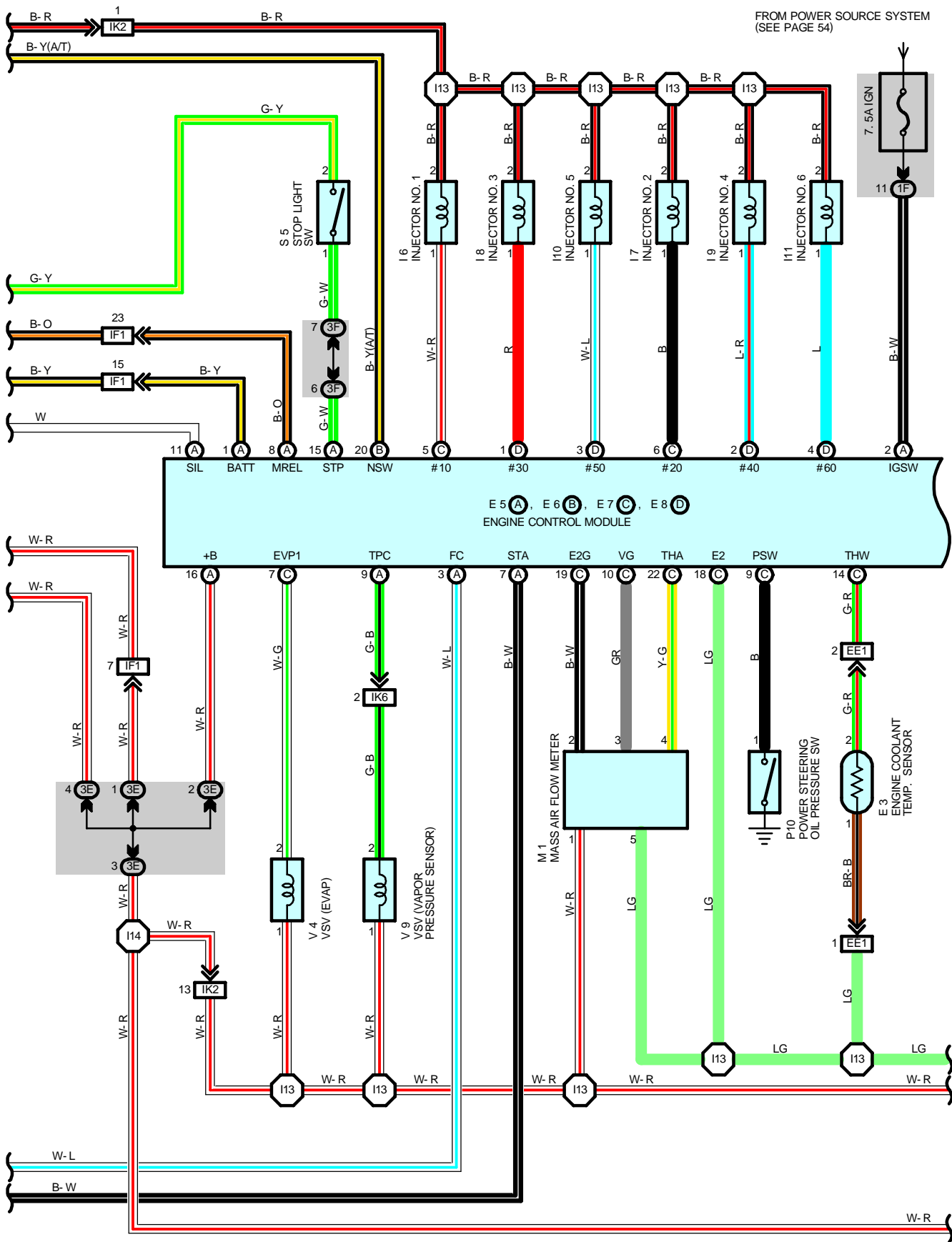

# ENGINE CONTROL (5VZ-FE)

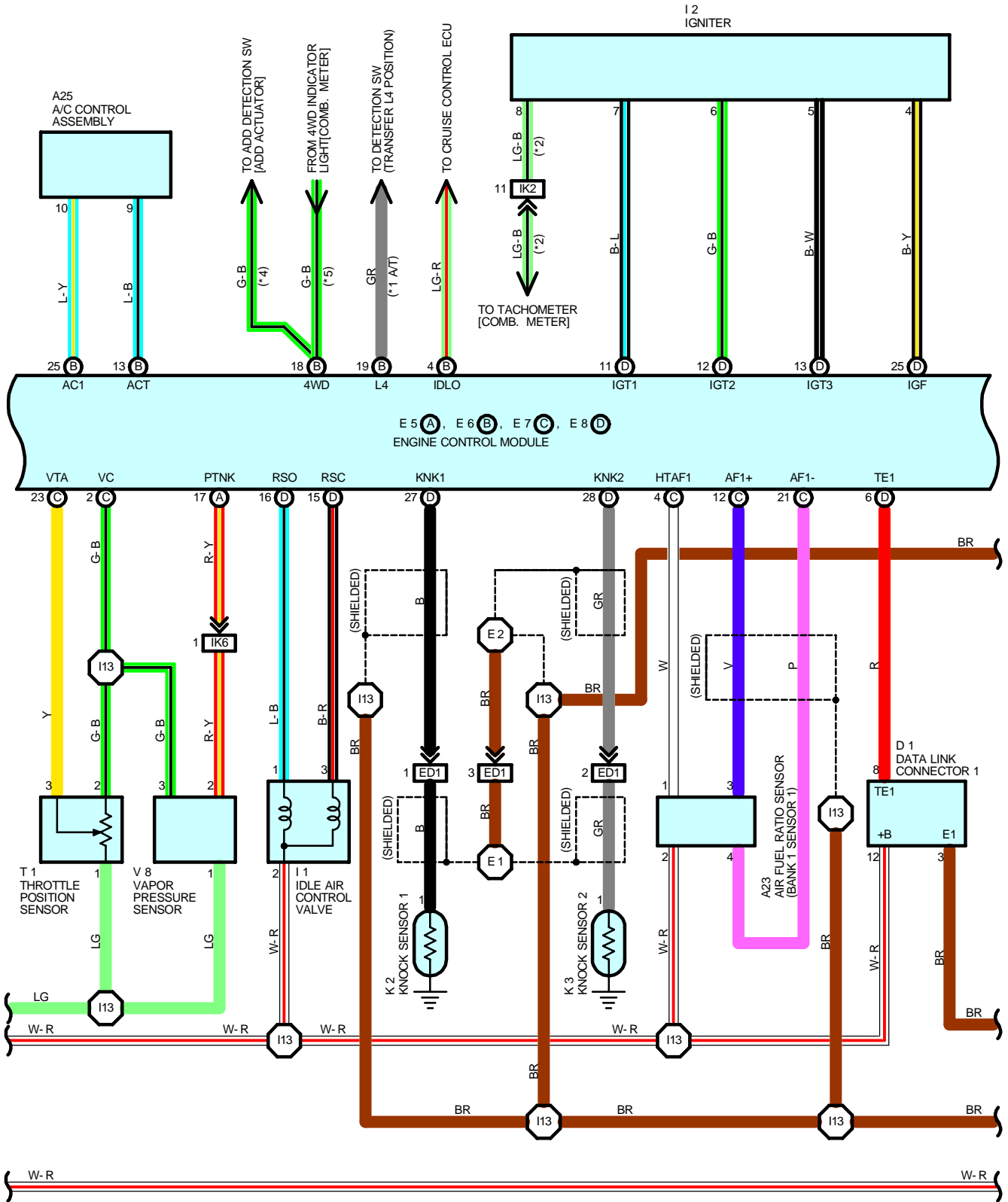

FROM POWER SOURCE SYSTEM (SEE PAGE 54)

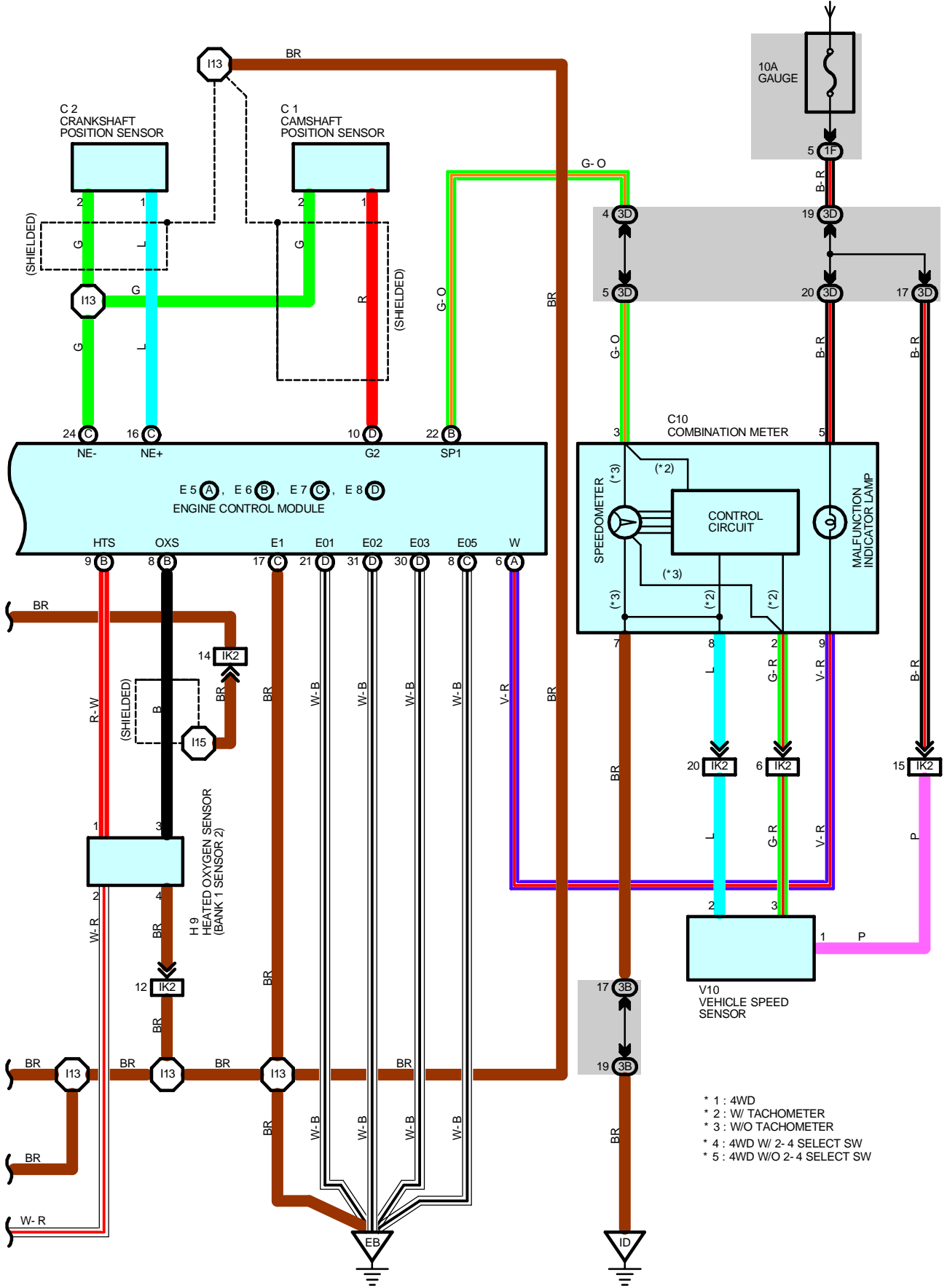

- \* 1 : 4WD
- \* 2 : W/ TACHOMETER
- \* 3 : W/O TACHOMETER
- \* 4 : 4WD W/ 2-4 SELECT SW
- \* 5 : 4WD W/O 2-4 SELECT SW

# ENGINE CONTROL (5VZ-FE)

## SYSTEM OUTLINE

The engine control system utilizes a microcomputer and maintains overall control of the engine, transmission, etc. An outline of engine control is given here.

### 1. INPUT SIGNAL

(1) Engine coolant temp. signal system

The engine coolant temp. sensor detects the engine coolant temp. and has a built-in thermistor with a resistance which varies according to the water temp. Thus the engine coolant temp. is input in the form of a control signal to TERMINAL THW of the engine control module.

(2) Intake air temp. signal system

The intake air temp. sensor is installed inside the mass air flow meter and detects the intake air temp., which is input as a control signal to TERMINAL THA of the engine control module.

(3) Heated oxygen sensor signal system

The oxygen density in the exhaust emissions is detected and input as a control signal to TERMINAL OXS of the engine control module. To maintain stable detection performance by the heated oxygen sensor, a heater is used for warming the sensor. The heater is also controlled by the engine control module (HTS).

(4) RPM signal system

Camshaft position and crankshaft position are detected by the camshaft position sensor and crankshaft position sensor, camshaft position is input as a control signal to TERMINAL G2 of the engine control module, and engine RPM is input to TERMINAL NE+.

(5) Throttle signal system

The throttle position sensor detects the throttle valve opening angle, which is input as a control signal to TERMINAL VTA of the engine control module.

(6) Vehicle speed signal system

The vehicle speed sensor detects the vehicle speed and inputs a control signal to TERMINAL SP1 of the engine control module via the combination meter.

(7) A/C SW signal system

The operating voltage of the A/C magnetic clutch is detected and input in the form of a control signal to TERMINAL AC1 of the engine control module.

(8) Battery signal system

Voltage is constantly applied to TERMINAL BATT of the engine control module. When the ignition SW is turned to on, voltage for engine control module operation is applied via the EFI relay to TERMINAL +B of the engine control module.

(9) Intake air volume signal system

Intake air volume is detected by the mass air flow meter and a signal is input into TERMINAL VG of the engine control module as a control signal.

(10) Stop light SW signal system

The stop light SW is used to detect whether or not the vehicle is braking and the information is input as a control signal to TERMINAL STP of the engine control module.

(11) Starter signal system

To confirm that the engine is cranking, the voltage applied to the starter motor during cranking is detected and is input as a control signal to TERMINAL STA of the engine control module.

(12) Engine knock signal system

Engine knocking is detected by the knock sensor 1 and 2 and the signals are input to TERMINALS KNK1 and KNK2 of the engine control module.

(13) 4WD signal system

Whether or not the vehicle is operating in 4WD mode is determined, and a control signal is input to TERMINAL 4WD of the engine control module.

(14) Air fuel ratio signal system

The air fuel ratio is detected and input as a control signal into TERMINAL AF1+ of the engine control module.

## **2. CONTROL SYSTEM**

### **\* SFI system**

The SFI system monitors the engine conditions through the signals (Input signals (1 to 13) ) input from each sensor to the engine control module. Based on this data and the program memorized in the engine control module, the most appropriate fuel injection timing is decided and current is output to TERMINALS #10, #20, #30, #40, #50 and #60 of the engine control module, causing the injectors to operate (to inject fuel). It is this system which, through the work of the engine control module, finely controls fuel injection in response to driving conditions.

### **\* Electronic Spark Advance system**

The ESA system monitors the engine conditions using the signals (input signals (1, 4, 5 to 7, 9, 11, 12) ) input to the engine control module from each sensor. Based on this data and the program memorized in the engine control module, the most appropriate ignition timing is decided and current is output to TERMINALS IGT1, IGT2 and IGT3 of the engine control module. This output controls the igniter to produce the most appropriate ignition timing for the driving conditions.

### **\* Heated oxygen sensor heater control system**

The heated oxygen sensor heater control system turns the heater to on when the intake air volume is low (Temp. of exhaust emissions low), and warms up the heated oxygen sensor to improve detection performance of the sensor. The engine control module evaluates the signals (Input signals (1, 4, 8, 9, 11) ) from each sensor, current is output to TERMINAL HTS and controls the heater.

## **3. DIAGNOSIS SYSTEM**

With the diagnosis system, when there is a malfunction in the ECU signal system, the malfunctioning system is recorded in the memory. The malfunctioning system can then be found by reading the display (Code) of the malfunction indicator lamp.

## **4. FAIL-SAFE SYSTEM**

When a malfunction occurs in any system, if there is a possibility of engine trouble being caused by continued control based on the signals from that system, the fail-safe system either controls the system by using data (Standard values) recorded in the engine control module memory or else stops the engine.

# ENGINE CONTROL (5VZ-FE)

## SERVICE HINTS

### EFI RELAY

5-3 : Closed with ignition SW at **ON** or **ST** position

### C6 CIRCUIT OPENING RELAY

5-3 : Closed with starter running or ignition SW at **ON** or **ST** position

### I6, I7, I8, I9, I10, I11 INJECTOR

1-2 : **13.4- 14.2** Ω

### T1 THROTTLE POSITION SENSOR

2-1 : **4- 9** kΩ

### E3 ENGINE COOLANT TEMP. SENSOR

1-2 : **10- 20** kΩ (-20 °C, -4 °F)

**4- 7** kΩ (0 °C, 32 °F)

**2- 3** kΩ (20 °C, 68 °F)

**0.9- 1.3** kΩ (40 °C, 104 °F)

**0.4- 0.7** kΩ (60 °C, 140 °F)

**0.2- 0.4** kΩ (80 °C, 176 °F)

### E5 (A), E6 (B), E7 (C), E8 (D) ENGINE CONTROL MODULE

Voltage at engine control module wiring connectors

+B-E1 : **9- 14** volts (Ignition SW on)

BATT-E1 : **9- 14** volts (Always)

VC-E2 : **4.5- 5.5** volts (Ignition SW on )

VTA-E2 : **0.3- 0.8** volts (Ignition SW on and throttle valve fully closed)

**3.2- 4.9** volts (Ignition SW on and throttle valve fully open)

STA-E1 : **6** volts or more (Ignition SW at **ST** position)

W-E1 : **9- 14** volts (No trouble and engine running)

THA-E2 : **0.5- 3.4** volts (Ignition SW on and intake air temp. **20 °C, 68 °F**)

THW-E2 : **0.2- 1.0** volts (Ignition SW on and coolant temp. **80 °C, 176 °F**)

SP1-E1 : Pulse generation with vehicle moving

STP-E1 : **7.5- 14** volts (Stop light SW on)

IGT1, IGT2, IGT3-E1 : Pulse generation (Cranking or idling)

#10, #20, #30, #40, #50, #60-E1 : **9- 14** volts (Ignition SW on)

### RESISTANCE AT ECU WIRING CONNECTOR

(Disconnect wiring connector)

VTA-E2 : **3.3- 10** kΩ (Throttle valve fully open)

**0.2- 0.8** kΩ (Throttle valve fully closed)

THA-E2 : **2- 3** kΩ (Intake air temp. **20 °C, 68 °F**)

THW-E2 : **0.2- 0.4** KΩ (Coolant temp. **80 °C, 178 °F**)

+B-E1 : **0.2- 0.4** kΩ

NE+ -E1 : **140- 180** Ω

## ○ : PARTS LOCATION

Code	See Page	Code	See Page	Code	See Page
A23	<a href="#">30 (5VZ-FE)</a>	F8	<a href="#">36 (Double Cab)</a>	J11	<a href="#">35</a>
A25	<a href="#">34</a>		<a href="#">37 (Except Double Cab)</a>	K2	<a href="#">31 (5VZ-FE)</a>
C1	<a href="#">30 (5VZ-FE)</a>	H9	<a href="#">35</a>	K3	<a href="#">31 (5VZ-FE)</a>
C2	<a href="#">30 (5VZ-FE)</a>	I1	<a href="#">31 (5VZ-FE)</a>	M1	<a href="#">31 (5VZ-FE)</a>
C6	<a href="#">34</a>	I2	<a href="#">31 (5VZ-FE)</a>	P1	<a href="#">31 (5VZ-FE)</a>
C9	<a href="#">34</a>	I6	<a href="#">31 (5VZ-FE)</a>	P10	<a href="#">31 (5VZ-FE)</a>
C10	<a href="#">34</a>	I7	<a href="#">31 (5VZ-FE)</a>	S5	<a href="#">35</a>
D1	<a href="#">30 (5VZ-FE)</a>	I8	<a href="#">31 (5VZ-FE)</a>	T1	<a href="#">31 (5VZ-FE)</a>
D7	<a href="#">34</a>	I9	<a href="#">31 (5VZ-FE)</a>	V4	<a href="#">31 (5VZ-FE)</a>
E3	<a href="#">30 (5VZ-FE)</a>	I10	<a href="#">31 (5VZ-FE)</a>	V8	<a href="#">31 (5VZ-FE)</a>
E5	A <a href="#">35</a>	I11	<a href="#">31 (5VZ-FE)</a>	V9	<a href="#">31 (5VZ-FE)</a>
E6	B <a href="#">35</a>	I14	<a href="#">35</a>	V10	<a href="#">31 (5VZ-FE)</a>
E7	C <a href="#">35</a>	J9	A <a href="#">31 (5VZ-FE)</a>		
E8	D <a href="#">35</a>	J10	B <a href="#">31 (5VZ-FE)</a>		

 : RELAY BLOCKS

Code	See Page	Relay Blocks (Relay Block Location)
2	21	R/B No.2 (Engine Compartment Left)

 : JUNCTION BLOCK AND WIRE HARNESS CONNECTOR

Code	See Page	Junction Block and Wire Harness (Connector Location)
1F	23	Cowl Wire and J/B No.1 (Lower Finish Panel)
1I	23	Engine Room Main Wire and J/B No.1 (Lower Finish Panel)
3A	24	Cowl Wire and J/B No.3 (Behind the Instrument Panel Left)
3B		
3D		
3E		
3F		

 : CONNECTOR JOINING WIRE HARNESS AND WIRE HARNESS

Code	See Page	Joining Wire Harness and Wire Harness (Connector Location)
ED1	40 (5VZ-FE)	Sensor Wire and Engine Wire (Over the Cylinder Head)
EE1	40 (5VZ-FE)	Engine Wire and Sensor Wire (Over the Cylinder Head)
IF1	44	Engine Room Main Wire and Cowl Wire (Left Kick Panel)
IK2	44	Engine Wire and Cowl Wire (Above the Glove Box)
IK3		
IK6		
BN1	46 (Double Cab) 48 (Except Double Cab)	Frame Wire and Cowl Wire (Under the Driver's Seat)

 : GROUND POINTS

Code	See Page	Ground Points Location
EA	40 (5VZ-FE)	Front Left Fender
EB	40 (5VZ-FE)	Near the Throttle Body
ID	44	Left Kick Panel
IE	44	Around the Right Edge of the Reinforcement
IG	44	Around the Left Edge of the Reinforcement

 : SPLICE POINTS

Code	See Page	Wire Harness with Splice Points	Code	See Page	Wire Harness with Splice Points
E1	40 (5VZ-FE)	Sensor Wire	I13	44	Engine Wire
E2	40 (5VZ-FE)	Engine Wire	I14	44	Cowl Wire
I3	44	Cowl Wire	I15		