

STARTING AND IGNITION (5VZ-FE)

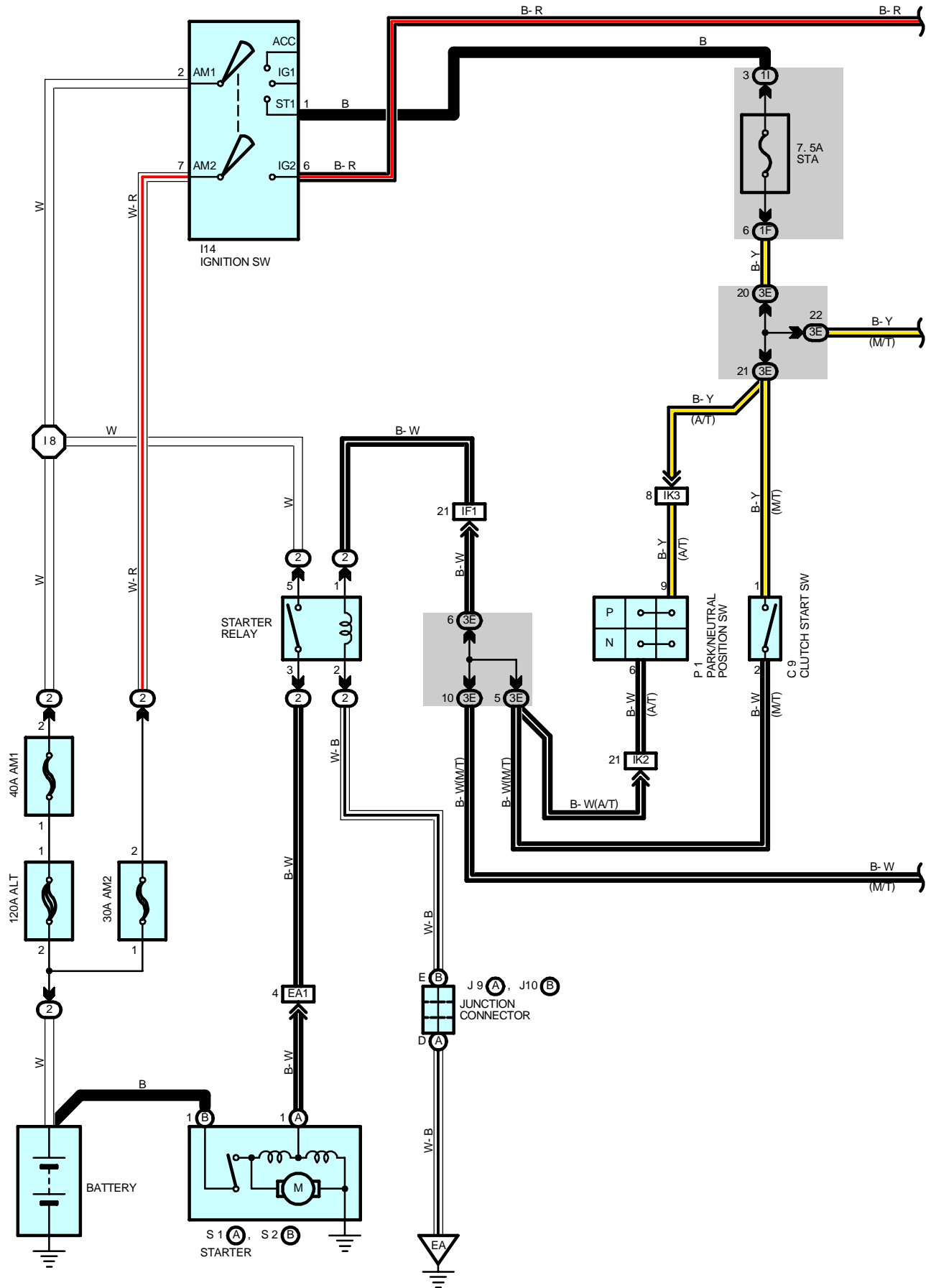

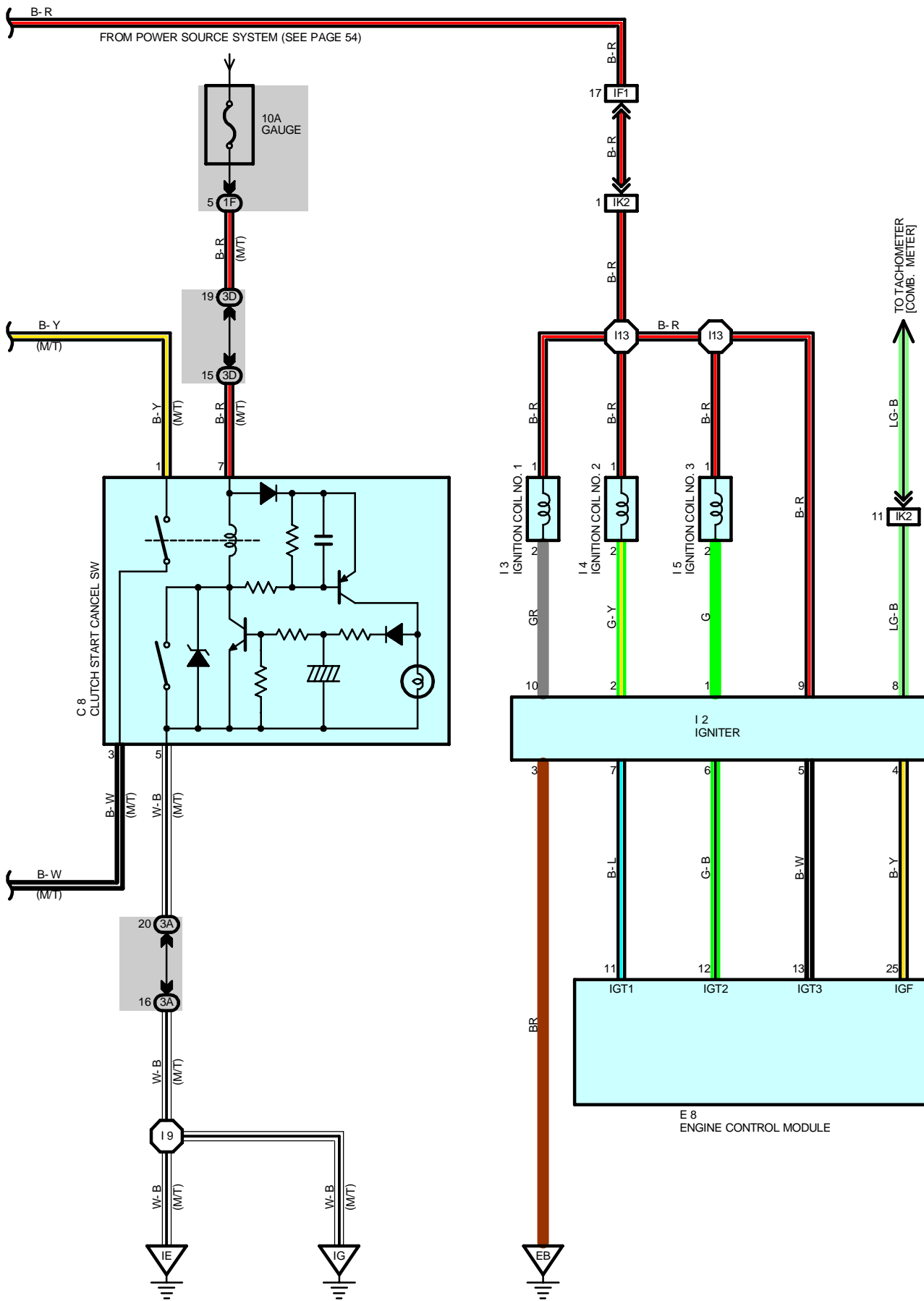

STARTING AND IGNITION (5VZ-FE)

SERVICE HINTS

S1 (A), S2 (B) STARTER

Points closed with Park/Neutral position SW at **P** or **N** position and ignition SW at **ST** position (A/T)
 Points closed with clutch start SW or clutch start cancel SW on and ignition SW at **ST** position (M/T)

I14 IGNITION SW

7-6 : Closed with ignition SW at **ON** or **ST** position
 2-1 : Closed with ignition SW at **ST** position

P1 PARK/NEUTRAL POSITION SW (A/T)

9-6 : Closed with A/T shift lever in **P** or **N** position

STARTER RELAY

5-3 : Closed with Park/Neutral position SW at **P** or **N** position and ignition SW at **ST** position (A/T)
 5-3 : Closed with clutch start SW or clutch start cancel SW on and ignition SW at **ST** position (M/T)

C8 CLUTCH START CANCEL SW (M/T)

1-3 : Closed with ignition SW on and cancel SW on

C9 CLUTCH START SW (M/T)

1-2 : Closed with clutch pedal fully depressed

○ : PARTS LOCATION

Code	See Page	Code	See Page	Code	See Page
C8	34	I4	31 (5VZ-FE)	P1	31 (5VZ-FE)
C9	34	I5	31 (5VZ-FE)	S1	A 31 (5VZ-FE)
E8	35	I14	35	S2	B 31 (5VZ-FE)
I2	31 (5VZ-FE)	J9	A 31 (5VZ-FE)		
I3	31 (5VZ-FE)	J10	B 31 (5VZ-FE)		

○ : RELAY BLOCKS

Code	See Page	Relay Blocks (Relay Block Location)
2	21	R/B No.2 (Engine Compartment Left)

○ : JUNCTION BLOCK AND WIRE HARNESS CONNECTOR

Code	See Page	Junction Block and Wire Harness (Connector Location)
1F	23	Cowl Wire and J/B No.1 (Lower Finish Panel)
1I	23	Engine Room Main Wire and J/B No.1 (Lower Finish Panel)
3A	24	Cowl Wire and J/B No.3 (Behind the Instrument Panel Left)
3D		
3E		

□ : CONNECTOR JOINING WIRE HARNESS AND WIRE HARNESS

Code	See Page	Joining Wire Harness and Wire Harness (Connector Location)
EA1	40 (5VZ-FE)	Engine Room Main Wire and Engine No.2 Wire (Near the Battery)
IF1	44	Engine Room Main Wire and Cowl Wire (Left Kick Panel)
IK2	44	Engine Wire and Cowl Wire (Above the Glove Box)
IK3		

▽ : GROUND POINTS

Code	See Page	Ground Points Location
EA	40 (5VZ-FE)	Front Left Fender
EB	40 (5VZ-FE)	Near the Throttle Body
IE	44	Around the Right Edge of the Reinforcement
IG	44	Around the Left Edge of the Reinforcement



: SPLICE POINTS

Code	See Page	Wire Harness with Splice Points	Code	See Page	Wire Harness with Splice Points
I8	44	Engine Room Main Wire	I13	44	Engine Wire
I9	44	Cowl Wire			