

<b>DTC</b>	<b>P0401</b>	<b>Exhaust Gas Recirculation Flow Insufficient Detected (Only for 3RZ-FE)</b>
------------	--------------	-------------------------------------------------------------------------------

**CIRCUIT DESCRIPTION**

The EGR system recirculates exhaust gas, which is controlled to the proper quantity to suit the driving conditions, into the intake air mixture to slow down combustion, reduce the combustion temperature and reduce NOx emissions. The amount of EGR is regulated by the EGR vacuum modulator according to the engine load.

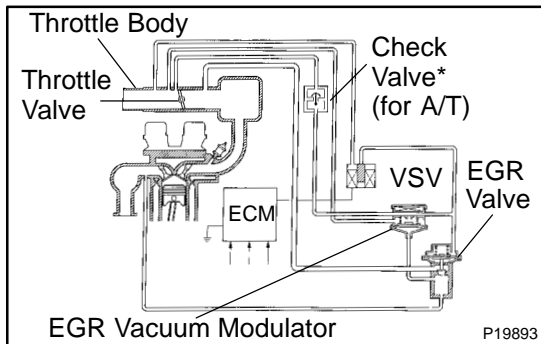

If even one of the following conditions is fulfilled, the VSV is turned ON by a signal from the ECM.

This results in atmospheric air acting on the EGR valve, closing the EGR valve and shutting off the exhaust gas (EGR cut-off). Under the following conditions, EGR is cut to maintain driveability.

- Before the engine is warmed up.
- During deceleration (throttle valve closed).
- Light engine load (amount of intake air very small).
- Engine racing.

DTC No.	DTC Detection Condition	Trouble Area
P0401	After engine is warmed up and run at 80 km/h (50 mph) for 3 to 5 minutes, small difference between value of EGR gas temp. sensor and ambient air temp. (2 trip detection logic)	<ul style="list-style-type: none"> <li>• Open in EGR gas temp. sensor circuit</li> <li>• EGR gas temp. sensor</li> <li>• Vacuum or EGR hose disconnected</li> <li>• Open or short in VSV circuit for EGR</li> <li>• VSV for EGR</li> <li>• EGR system</li> <li>• EGR vacuum modulator</li> <li>• EGR valve stuck closed</li> <li>• ECM</li> </ul>

## WIRING DIAGRAM

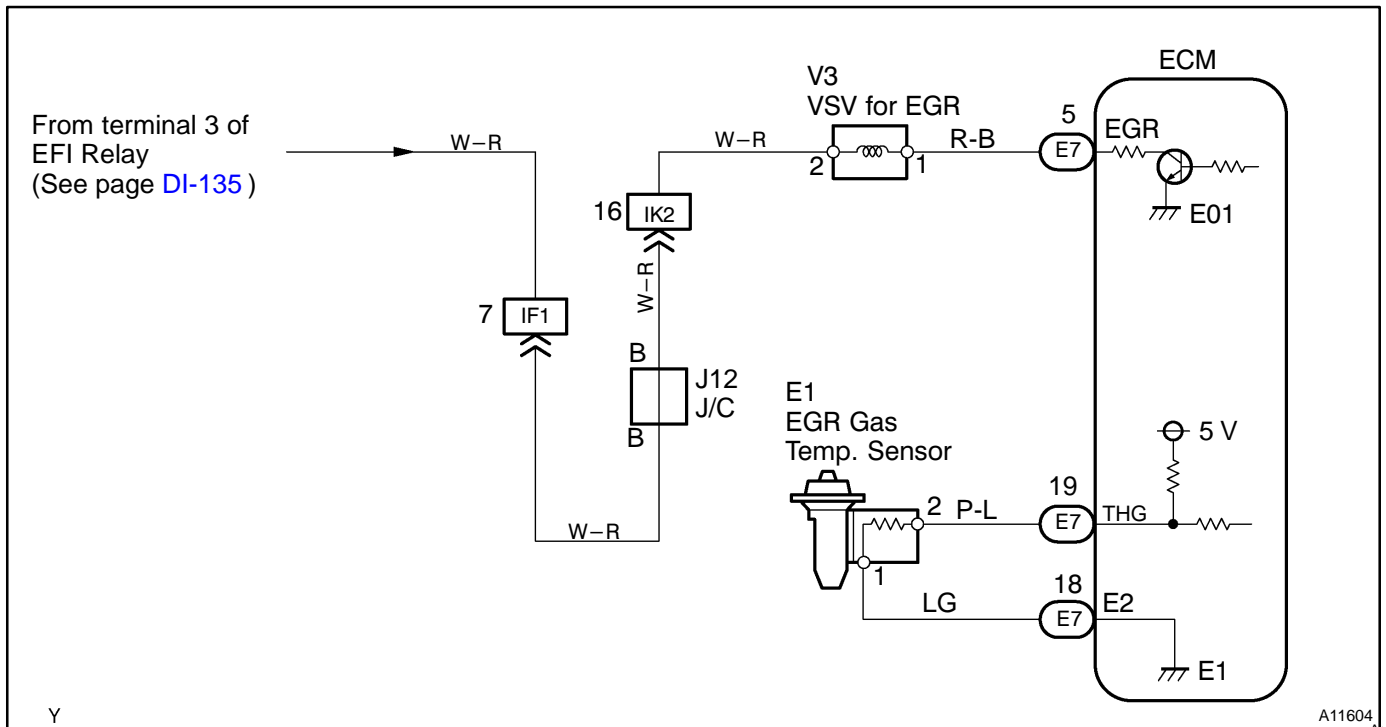

## SYSTEM CHECK DRIVING PATTERN

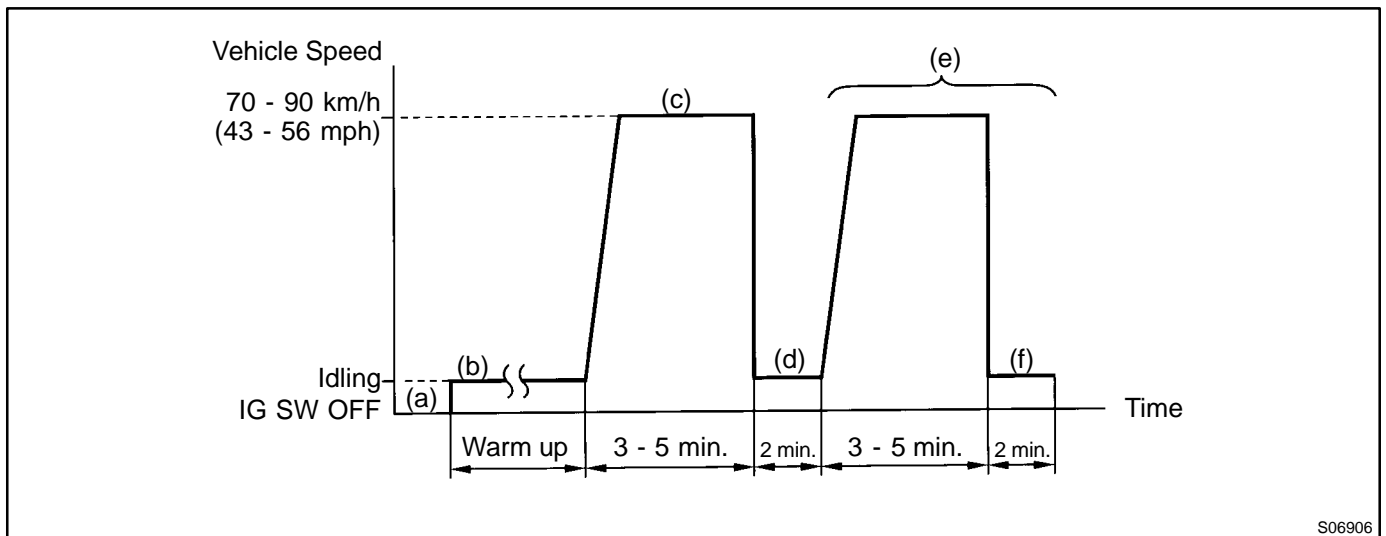

- Connect the OBD II scan tool or TOYOTA hand-held tester to the DLC3.
- Start and warm up the engine with all the accessories switched OFF.
- Run the vehicle at 70 - 90 km/h (43 - 56 mph) for 3 minutes or more.
- Idle the engine for about 2 minutes.
- Do steps (c) and (d) again.
- Check the READINESS TESTS mode on the OBD II scan tool or TOYOTA hand-held tester. If COMPL is displayed and the MIL does not light up, the system is normal. If INCMPL is displayed and the MIL does not light up, run the vehicle step (e) from some times and check it.

### HINT:

INCMPL is displayed when either condition (1) or (2) exists.

- The system check is incomplete.

(2) There is a malfunction in the system.

If there is a malfunction in the system, the MIL will light up after steps (b) to (e) above are done (2 trip detection logic).

## INSPECTION PROCEDURE

HINT:

Read freeze frame data using TOYOTA hand-held tester or OBD II scan tool, as freeze frame data records the engine conditions when a malfunction is detected. When troubleshooting, it is useful for determining whether the vehicle was running or stopped, the engine was warmed up or not, the air-fuel ratio was lean or rich, etc. at the time of the malfunction.

### TOYOTA hand-held tester:

<b>1</b>	<b>Connect TOYOTA hand-held tester, and read value of EGR gas temperature value.</b>
----------	--------------------------------------------------------------------------------------

#### PREPARATION:

(a) Connect the TOYOTA hand-held tester to the DLC3.

(b) Turn the ignition switch ON and push the TOYOTA hand-held tester main switch ON.

#### CHECK:

Read the EGR gas temperature on the TOYOTA hand-held tester.

#### OK:

**EGR gas temperature: 10°C (50°F) or more**

HINT:

If there is an open circuit, the TOYOTA hand-held tester indicates 3.1°C (37.6°F).

OK

Go to step 4.

NG

<b>2</b>	<b>Check for open in harness or ECM.</b>
----------	------------------------------------------

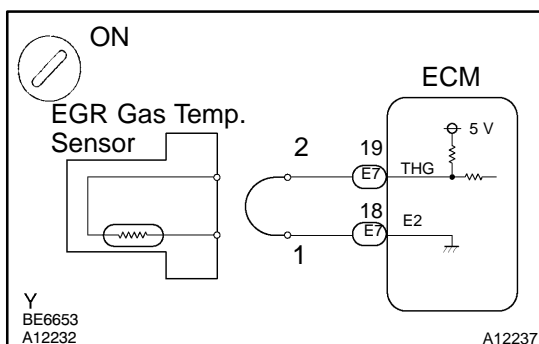

#### PREPARATION:

(a) Disconnect the EGR gas temperature sensor connector.

(b) Connect the sensor wire harness terminals together.

(c) Turn the ignition switch ON.

#### CHECK:

Read the EGR gas temperature on the TOYOTA hand-held tester.

#### OK:

**EGR gas temperature: 159.3°C (318.7°F)**

OK

Confirm good connection at sensor. If OK, replace EGR gas temperature sensor.

NG

**3 Check for open in harness or ECM.**

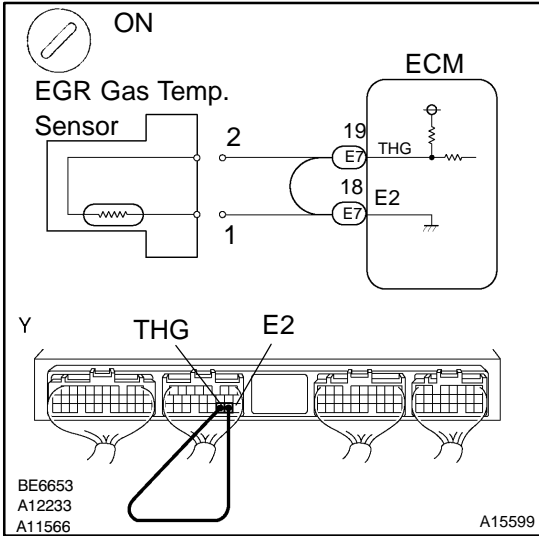

**PREPARATION:**

- (a) Remove the glove compartment (See page [SF-49](#)).
- (b) Connect between terminals THG and E2 of the ECM connector.

**HINT:**

The EGR gas temperature sensor connector is disconnected. Before checking, do a visual check and contact pressure check for the ECM connector (See page [IN-28](#)).

**CHECK:**

Read the EGR gas temperature on the TOYOTA hand-held tester.

**OK:**

**EGR gas temperature: 159.3°C (318.7°F)**

**OK** → **Open in harness between terminal E2 or THG. Repair or replace harness.**

**NG**

**Confirm connection at ECM. If OK, replace ECM.**

**4 Check connection of vacuum hose and EGR hose (See page [EC-4](#)).**

**NG** → **Repair or replace.**

**OK**

**5 Check VSV for EGR.**

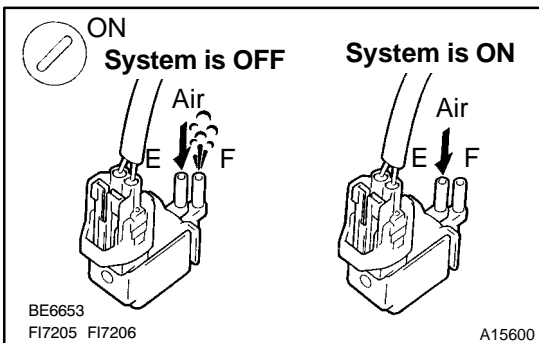

**PREPARATION:**

Select the ACTIVE TEST mode on the TOYOTA hand-held tester.

**CHECK:**

Check the operation of the VSV when it is operated by the TOYOTA hand-held tester.

**OK:**

**EGR system is OFF:  
Air from port E flows out through port F.**

EGR system is ON:  
Air does not flow from port E to port F.

**OK** → Go to step 8.

**NG**

**6** Check operation of VSV for EGR (See page [EC-9](#)).

**NG** → Replace VSV for EGR.

**OK**

Check for short in harness and connector between VSV and ECM (See page [IN-28](#)).

**7** Check EGR system (See page [EC-9](#)).

**NG** → Repair or replace.

**OK**

**8** Check EGR vacuum modulator (See page [EC-9](#)).

**NG** → Repair or replace.

**OK**

**9** Check EGR valve (See page [EC-9](#)).

**NG** → Repair or replace.

**OK**

<b>10</b>	<b>Check value of EGR gas temperature sensor.</b>
-----------	---------------------------------------------------

**PREPARATION:**

- (a) Connect the TOYOTA hand-held tester to the DLC3.
- (b) Turn the ignition switch ON and push the TOYOTA hand-held tester main switch ON.
- (c) Select the ACTIVE TEST mode on the TOYOTA hand-held tester (EGR system ON).
- (d) Race the engine at 4,000 rpm for 3 min.

**CHECK:**

Measure the EGR gas temperature while racing the engine at 4,000 rpm.

**OK:**

**EGR gas temperature after 3 minutes 100°C (212°F) or more**

**NG**

**Replace EGR gas temperature sensor.**

**OK**

**Check and replace ECM (See page [IN-28](#) ).**

**OBD II scan tool (excluding TOYOTA hand-held tester):**

<b>1</b>	<b>Check resistance of EGR gas temperature sensor.</b>
----------	--------------------------------------------------------

EGR Gas Temp. Sensor  
Connector

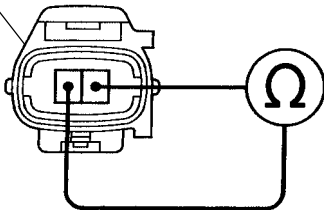

P24322

**PREPARATION:**

Disconnect the EGR gas temperature sensor connector.

**CHECK:**

Measure the resistance between terminals of the EGR gas temperature sensor connector.

**OK:**

**Resistance: 600 kΩ or less**

**HINT:**

If there is open circuit, ohmmeter indicates 720 kΩ or more.

**NG**

**Check and replace EGR gas temperature sensor (See page [EC-9](#) ).**

**OK**

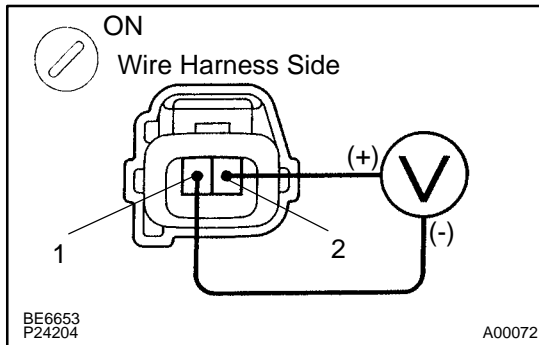
**2 Check for open in harness or ECM.****PREPARATION:**

- Disconnect the EGR gas temperature sensor connector.
- Turn the ignition switch ON.

**CHECK:**

Measure the voltage between terminals of the EGR gas temperature sensor wire harness side connector.

**OK:**

**Voltage: 4.5 - 5.5 V**

**OK**

**Go to step 4.**

**NG**

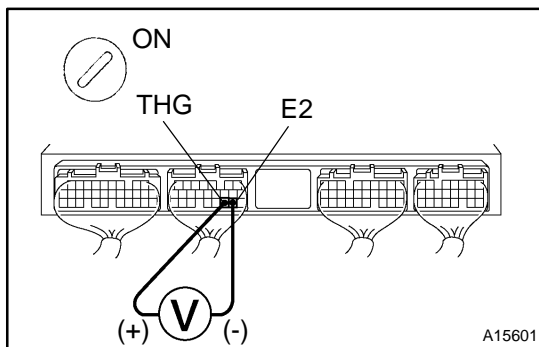
**3 Check for open in harness or ECM.****PREPARATION:**

- Remove the glove compartment (See page [SF-49](#)).
- Turn the ignition switch ON.

**CHECK:**

Measure the voltage between terminals of THG and E2 of the ECM connector.

**HINT:**

The EGR gas temperature sensor connector is disconnected.

**OK:**

**Voltage: 4.5 - 5.5 V**

**OK**

**Open in harness between terminals E2 or THG. Repair or replace harness.**

**NG**

**Confirm connection at ECM. If OK, replace ECM.**

**4 Check connection of vacuum hose and EGR hose (See page [EC-4](#)).**

**NG**

**Repair or replace.**

OK

**5 Check VSV for EGR.**

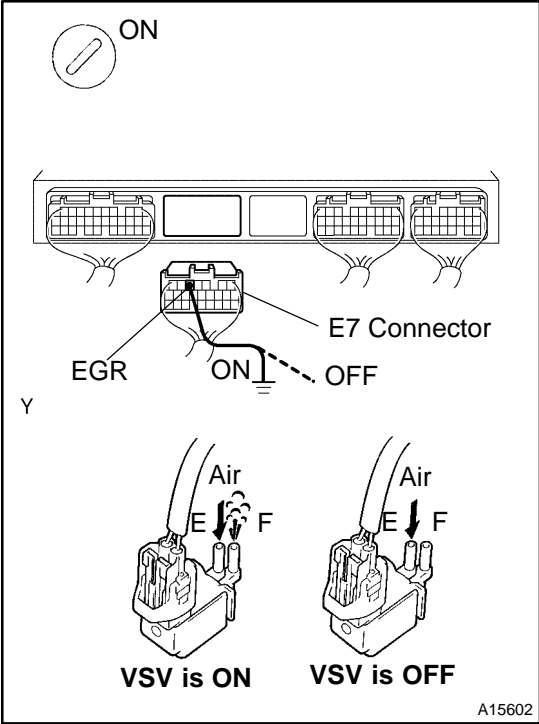

**PREPARATION:**

- (a) Remove the glove compartment (See page SF-49 ).
- (b) Disconnect the E7 connector from the ECM.
- (c) Turn the ignition switch ON.

**CHECK:**

Check the VSV function.

- (1) Connect terminal EGR of the ECM connector and the body ground (ON).
- (2) Disconnect terminal EGR of ECM connector and the body ground (OFF).

**OK:**

- (1) **VSV is ON:**  
Air from port E flows out through port F.
- (2) **VSV is OFF:**  
Air does not flow from port E to port F.

OK → Go to step 8.

NG

**6 Check operation for VSV for EGR (See page EC-9).**

NG → Replace VSV for EGR.

OK

Check for open in harness and connector between R/B No.2 and ECM (See page IN-28 ).

**7 Check EGR system (See page EC-9).**

NG → Repair or replace.



OK

8 Check EGR vacuum modulator (See page EC-9).

NG

Repair or replace.

OK

9 Check EGR valve (See page EC-9).

NG

Repair or replace.

OK

10 Check resistance of EGR gas temperature sensor.

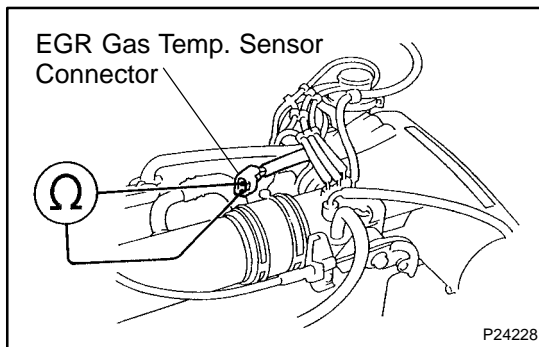
**PREPARATION:**

- Disconnect the EGR gas temperature sensor connector.
- Start the engine and warm it up.
- Disconnect the VSV connector for the EGR.
- Race the engine at 4,000 rpm for 3 min.

**CHECK:**

Measure the resistance of the EGR gas temperature sensor while racing the engine at 4,000 rpm.

**OK:**

**Resistance of EGR gas temperature sensor after 3 min.: 4.3 kΩ or less**

**HINT:**

188.6 - 439.0 kΩ for resistance at 20°C (68°F)

NG

Replace EGR gas temperature sensor.

OK

Check and replace ECM (See page IN-28).