

<b>DTC</b>	<b>P0335</b>	<b>Crankshaft Position Sensor "A" Circuit Malfunction</b>
------------	--------------	---

### CIRCUIT DESCRIPTION

Crankshaft position sensor (NE signal) consists of and pickup coil. The NE signal plate has 34 teeth and is mounted on the crankshaft. The NE signal sensor generates 34 signals at every engine revolution. The ECM detects the standard crankshaft angle based on the G signal, and the actual crankshaft angle and the engine speed by the NE signal.

DTC No.	DTC Detection Condition	Trouble Area
P0335	No crankshaft position sensor signal to ECM during cranking (2 trip detection logic)	<ul style="list-style-type: none"> <li>• Open or short in crankshaft position sensor circuit</li> <li>• Crankshaft position sensor</li> <li>• Signal plate (Crankshaft position sensor rotor)</li> <li>• ECM</li> </ul>
	No crankshaft position sensor signal to ECM with engine speed 600 rpm or more (2 trip detection logic)	

### WIRING DIAGRAM

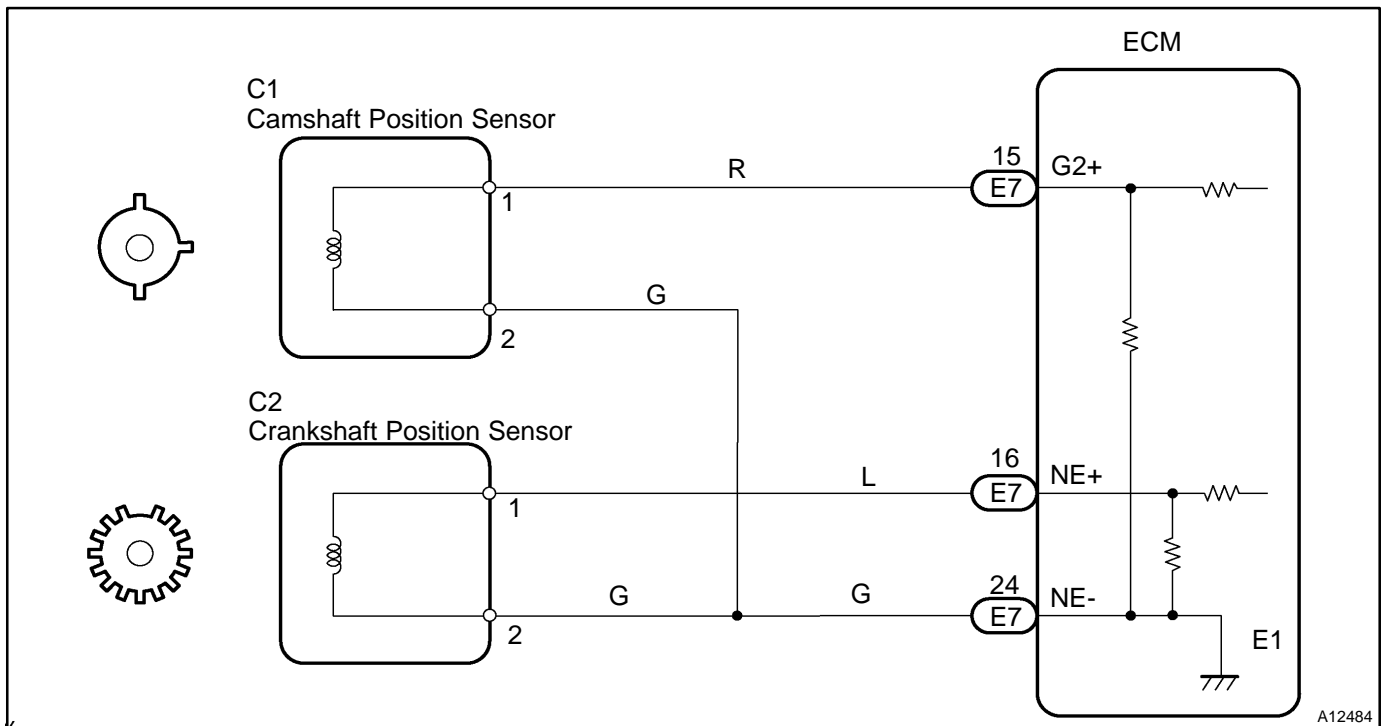

### INSPECTION PROCEDURE

**HINT:**

- Perform troubleshooting of DTC P0335 first. If no trouble is found, troubleshoot the following mechanical system.
- Read freeze frame data using TOYOTA hand-held tester or OBD II scan tool, as freeze frame data records the engine conditions when a malfunction is detected. When troubleshooting, it is useful for determining whether the vehicle was running or stopped, the engine was warmed up or not, the air-fuel ratio was lean or rich, etc. at the time of the malfunction.

**1 Check resistance of crankshaft position sensor (See page IG-1 ).**

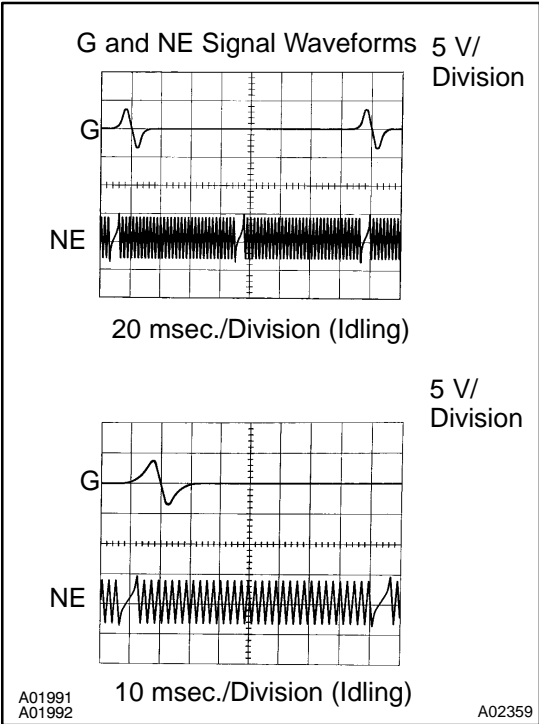

**Reference: INSPECTION USING OSCILLOSCOPE**

California Spec.  
During cranking or idling, check the waveforms between terminals G2 and NE-, and NE+ and NE- of the ECM connector.  
HINT:  
The correct waveforms are as shown.

**NG** Replace crankshaft position sensor.

**OK**

**2 Check for open and short in harness and connector between ECM and crankshaft position sensor (See page IN-28 ).**

**NG** Repair or replace harness or connector.

**OK**

**3 Inspect sensor installation and teeth of signal plate.**

**NG** Tighten sensor. Replace signal plate.

**OK**

**Check and replace ECM (See page IN-28 ).**