

DTC	P0120	Throttle/Pedal Position Sensor/Switch "A" Circuit Malfunction
------------	--------------	--

CIRCUIT DESCRIPTION

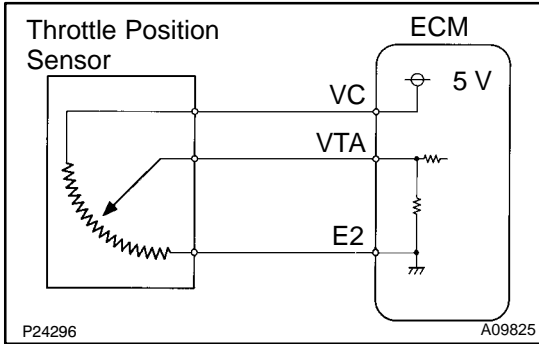

The throttle position sensor is mounted in the throttle body and detects the throttle valve opening angle. When the throttle valve is fully closed, a voltage of approximately 0.3 - 0.8 V is applied to terminal VTA of the ECM. The voltage applied to the terminals VTA of the ECM increases in proportion to the opening angle of the throttle valve and becomes approximately 3.2 - 4.9 V when the throttle valve is fully opened. The ECM judges the vehicle driving conditions from these signals input from terminal VTA, uses it as one of the conditions to decide the air-fuel ratio correction, power increase correction and fuel-cut control etc.

DTC No.	DTC Detection Condition	Trouble Area
P0120	Condition (a) or (b) continues with more than 5 sec.: (a) VTA < 0.1 V (b) VTA > 4.9 V	<ul style="list-style-type: none"> • Open or short in throttle position sensor circuit • Throttle position sensor • ECM

HINT:

After confirming DTC P0120, use the OBD II scan tool or TOYOTA hand-held tester to confirm the throttle valve opening percentage and closed throttle position switch condition.

Throttle valve opening position expressed as percentage		Trouble Area
Throttle valve fully closed	Throttle valve fully open	
0 %	0 %	<ul style="list-style-type: none"> • VC circuit open • VTA circuit open or short
Approx. 100 %	Approx. 100 %	<ul style="list-style-type: none"> • E2 circuit open

WIRING DIAGRAM

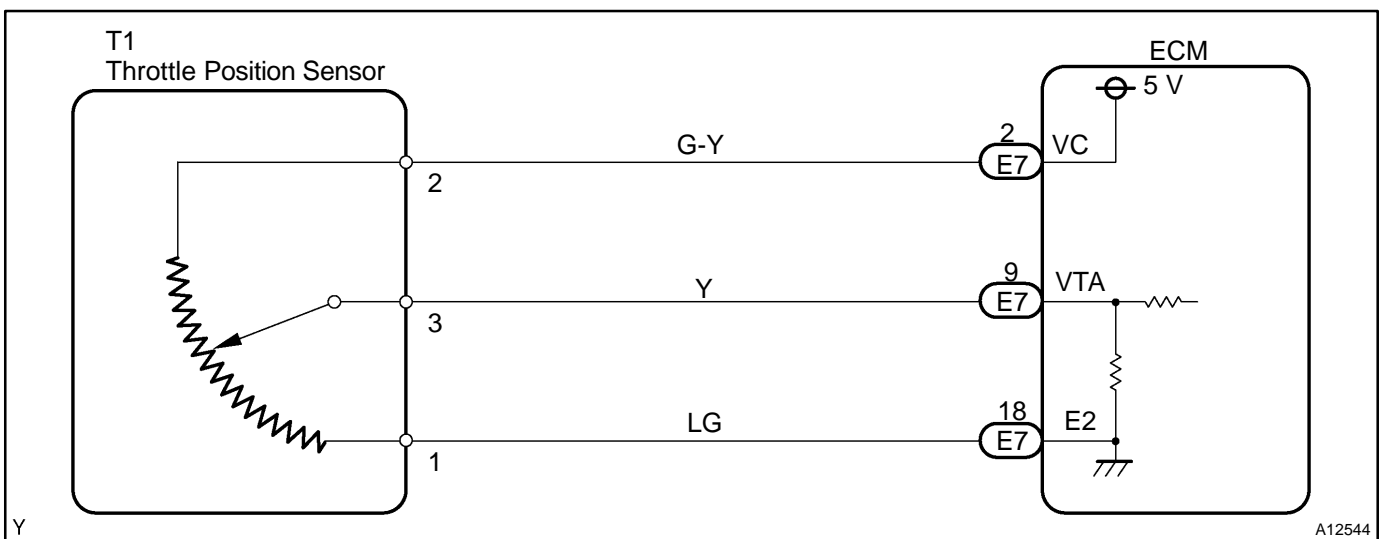

INSPECTION PROCEDURE

HINT:

- If DTCs P0110, P0115 and P0120 are output simultaneously, E2 (sensor ground) may be open.
- Read freeze frame data using TOYOTA hand-held tester or OBD II scan tool, as freeze frame data records the engine conditions when a malfunction is detected. When troubleshooting, it is useful for determining whether the vehicle was running or stopped, the engine was warmed up or not, the air-fuel ratio was lean or rich, etc. at the time of the malfunction.

- 1 Connect OBD II scan tool or TOYOTA hand-held tester, and read throttle valve opening percentage.**

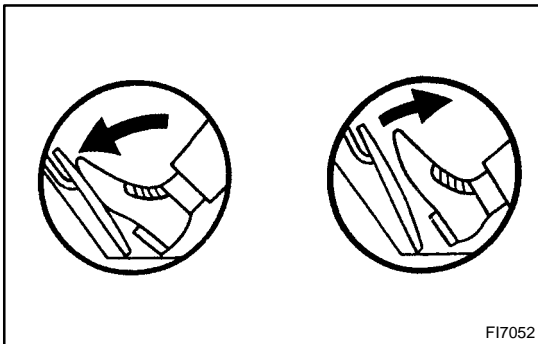

F17052

PREPARATION:

- Connect the OBD II scan tool or TOYOTA hand-held tester to DLC3.
- Turn the ignition switch ON and push the OBD II scan tool or TOYOTA hand-held tester main switch ON.

CHECK:

Read the throttle valve opening percentage.

OK:

Throttle valve	Throttle valve opening position expressed as percentage
Fully open	Approx. 75 %
Fully closed	Approx. 10 %

OK

Check for intermittent problems (See page DI-3).

NG

- 2 Check voltage between terminal 2 of throttle position sensor connector and body ground.**

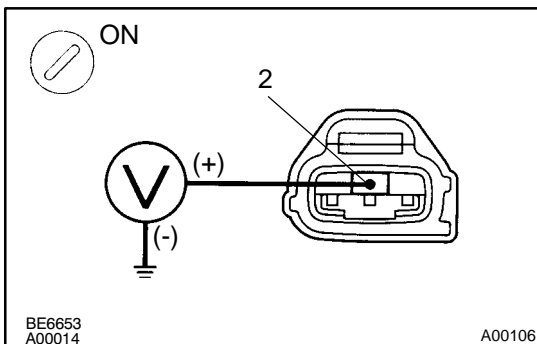
BE6653
A00014

A00106

PREPARATION:

- Disconnect the throttle position sensor connector.
- Turn the ignition switch ON.

CHECK:

Measure the voltage between terminal 2 of the throttle position sensor connector and the body ground.

OK:

Voltage: 4.5 - 5.5 V

NG

Go to step 5.

OK

3 Check throttle position sensor (See page SF-30).

NG Replace throttle position sensor.

OK

4 Check voltage between terminals VTA and E2 of ECM connector.

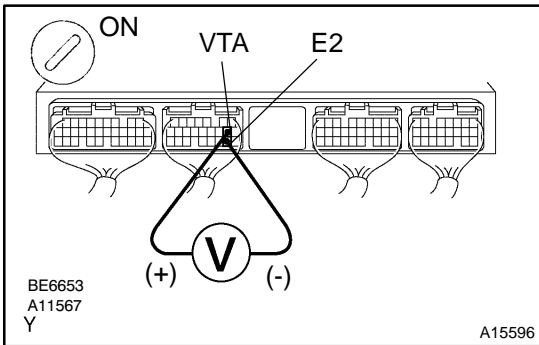

PREPARATION:

- (a) Remove the glove compartment (See page SF-49).
- (b) Turn the ignition switch ON.

CHECK:

Measure the voltage between terminals VTA and E2 of the ECM connector.

OK:

Throttle Valve	Voltage
Fully closed	0.3 - 0.8 V
Fully open	3.2 - 4.9 V

NG Check for open and short in harness and connector between ECM and throttle position sensor in VTA circuit (See page IN-28).

OK

Check and replace ECM (See page IN-28).

5 Check voltage between terminals VC and E2 of ECM connector.

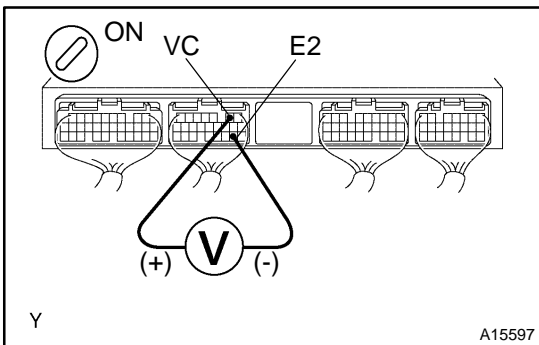

PREPARATION:

- (a) Remove the glove compartment (See page SF-49).
- (b) Turn the ignition switch ON.

CHECK:

Measure the voltage between terminals VC and E2 of the ECM connector.

OK:

Voltage: 4.5 - 5.5 V

NG Check and replace ECM (See page IN-28).

The icon is a shield-shaped box with a pointed bottom, containing the text "OK".

OK

Check for open in harness and connector in VC circuit between ECM throttle position and sensor (See page [IN-28](#)).