

## PRE-CHECK

### 1. DIAGNOSIS SYSTEM

#### (a) Description

- When troubleshooting OBD II vehicles, the only difference from the usual troubleshooting procedure is that you need to connect the vehicle to the OBD II scan tool complying with SAE J1978 or TOYOTA hand-held tester, and read off various data output from the vehicle's ECM.
- OBD II regulations require that the vehicle's on-board computer lights up the Malfunction Indicator Light (MIL) on the instrument panel when the computer detects a malfunction in the emission control system/components or in the powertrain control components which affect vehicle emissions, or a malfunction in the computer. In addition to the MIL lighting up when a malfunction is detected, the applicable Diagnostic Trouble Codes (DTCs) prescribed by SAE J2012 are recorded in the ECM memory (See page [DI-14](#)).

If the malfunction does not reoccur in 3 consecutive trips, the MIL goes off automatically but the DTCs remain recorded in the ECM memory.

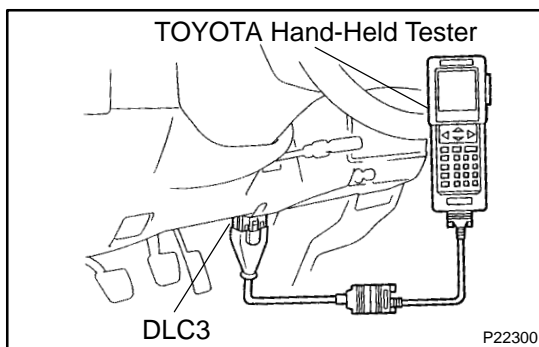
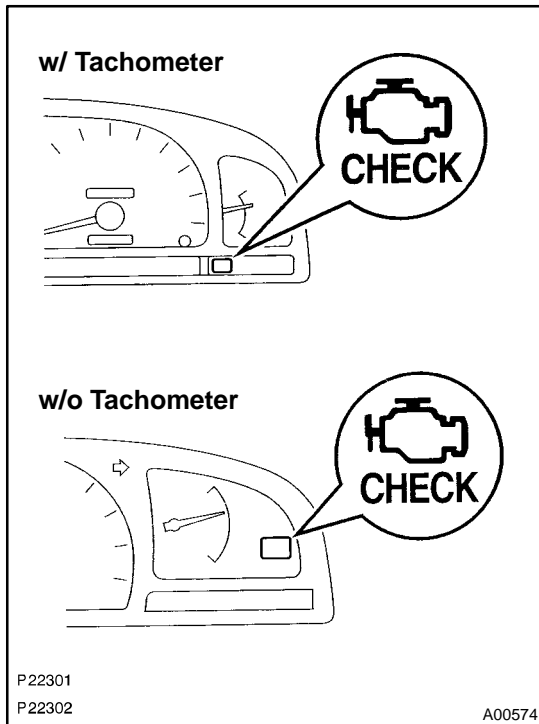

- To check the DTCs, connect the OBD II scan tool or TOYOTA hand-held tester to the Data Link Connector 3 (DLC3) on the vehicle. The OBD II scan tool or TOYOTA hand-held tester also enables you to erase the DTCs and check freeze frame data and various forms of engine data (For operating instructions, see the OBD II scan tool's instruction book.). DTCs include SAE controlled codes and manufacturer controlled codes. SAE controlled codes must be set as prescribed by the SAE, while manufacturer controlled codes can be set freely by a manufacturer within the prescribed limits (See DTC chart on page [DI-14](#)).

- The diagnosis system operates in the normal mode during normal vehicle use. It also has a check mode for technicians to simulate malfunction symptoms and troubleshoot. Most DTCs use 2 trip detection logic\* to prevent an erroneous detection and ensure the malfunction detection. By switching the ECM to the check mode when troubleshooting, a technician can cause the MIL to light up for a malfunction that is only detected once or momentarily. (TOYOTA hand-held tester only) (See step 2)
- \*2 trip detection logic:  
When a malfunction is first detected, the malfunction is temporarily stored in the ECM memory. (1st trip)

If the same malfunction is detected again during the second drive test, this second detection causes the MIL to light up. (2nd trip) (However, the ignition switch must be turned OFF between the 1st trip and 2nd trip.)

- Freeze frame data:  
Freeze frame data records the engine condition when a misfire (DTCs P0300 - P0304) or fuel trim malfunction (DTCs P0171 and P0172) or other malfunction (first malfunction only) is detected. Freeze frame data records the engine conditions (fuel system, calculated load, engine coolant temperature, fuel trim, engine speed, vehicle speed, etc.) when the malfunction is detected. When troubleshooting, it is useful for determining whether the vehicle was running or stopped, the engine was warmed up or not, the air-fuel ratio was lean or rich, etc. at the time of the malfunction.

Priorities for troubleshooting:

If troubleshooting priorities for multiple DTCs are given in the applicable DTC chart, these should be followed.

If no instructions are given, troubleshoot DTCs according to the following priorities.

- (1) DTCs other than fuel trim malfunction (DTCs P0171 and P0172), EGR (DTCs P0401 and P0402), and misfire (DTCs P0300 - P0304).
- (2) Fuel trim malfunction (DTCs P0171 and P0172), and EGR (DTCs P0401 and P0402).
- (3) Misfire (DTCs P0300 - P0304).

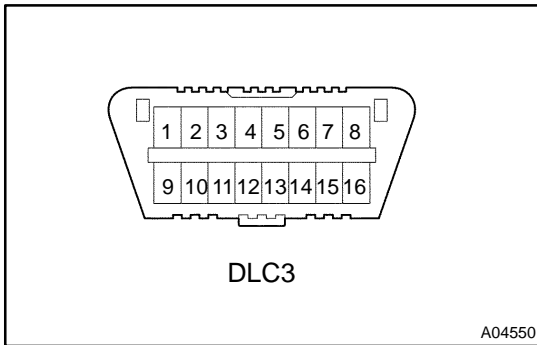

- (b) Check the DLC3.  
The vehicle's ECM uses the ISO 9141-2 communication protocol. The terminal arrangement of the DLC3 complies with SAE J1962 and matches the ISO 9141-2 format.

Terminal No.	Connection/Voltage or Resistance	Condition
7	Bus (+) Line/Pulse generation	During transmission
4	Chassis Ground - Body Ground/1 $\Omega$ or less	Always
5	Signal Ground - Body Ground/1 $\Omega$ or less	Always
16	Battery Positive - Body Ground/9 - 14 V	Always

**HINT:**

If your display shows **UNABLE TO CONNECT TO VEHICLE** when you have connected the cable of the OBD II scan tool or TOYOTA hand-held tester to the DLC3, turned the ignition switch ON and operated the scan tool, there is a problem on the vehicle side or tool side.

- If the communication is normal when the tool is connected to another vehicle, inspect the DLC3 of the original vehicle.
- If the communication is still not possible when the tool is connected to another vehicle, the problem is probably in the tool itself, so consult the Service Department listed in the tool's instruction manual.

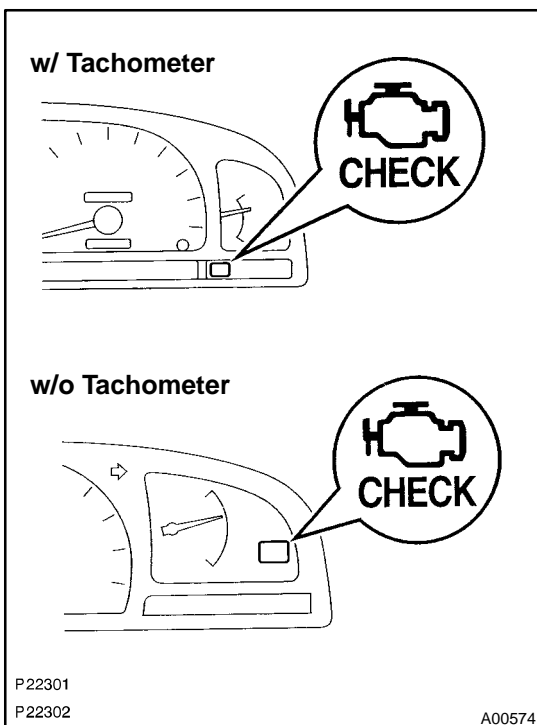

**2. Normal Mode:**  
**INSPECT DIAGNOSIS**

- (a) Check the MIL.  
(1) The MIL comes on when the ignition switch is turned ON and the engine is not running.

**HINT:**

If the MIL does not light up, troubleshoot the combination meter (See page [BE-2](#)).

- (2) When the engine started, the MIL should go off. If the light remains on, the diagnosis system has detected a malfunction or abnormality in the system.
- (b) Check the DTC.

**NOTICE:**

- If there is no DTC in the normal mode, check the 1st trip DTC using **Continuous Test Results** function (Mode 7 for SAE J1979) on the OBD II scan tool or TOYOTA hand-held tester.

- **TOYOTA hand-held tester only:**  
**When the diagnosis system is switched from the normal mode to the check mode, all the DTCs and freeze frame data recorded in the normal mode will be erased. So before switching modes, always check the DTCs and freeze frame data, and note them down.**
  - (1) Prepare the OBD II scan tool (complying with SAE J1978) or TOYOTA hand-held tester.
  - (2) Connect the OBD II scan tool or TOYOTA hand-held tester to the DLC3 at the lower left of the instrument panel.
  - (3) Turn the ignition switch ON and turn the OBD II scan tool or TOYOTA hand-held tester switch ON.
  - (4) Use the OBD II scan tool or TOYOTA hand-held tester to check the DTCs and freeze frame data and note them down (For operating instructions, see the OBD II scan tool's instruction book.).

If there is no DTC in the normal mode, check the 1st trip DTC using Continuous Test Results function (Mode 7 for SAE J1979) on the OBD II scan tool or TOYOTA hand-held tester.

- (5) See page [DI-14](#) to confirm the details of the DTCs.

**NOTICE:**

- **When simulating symptoms with an OBD II scan tool (excluding TOYOTA hand-held tester) to check the DTCs, use the normal mode. For code on the DTC chart subject to "2 trip detection logic", perform the following either action.**
  - **Turn the ignition switch OFF after the symptom is simulated the first time. Then repeat the simulation process again. When the problem has been simulated twice, the MIL lights up and the DTCs are recorded in the ECM.**
  - **Check the 1st trip DTC using Mode 7 (Continuous Test Results) for SAE J1979.**
- (c) Clear the DTC.
- The DTCs and freeze frame data will be erased by either action.
- Operating the OBD II scan tool (complying with SAE J1978) or TOYOTA hand-held tester to erase the codes (See the OBD II scan tool's instruction book for operating instructions.).
  - Disconnecting the battery terminals or EFI fuse.

**NOTICE:**

If the TOYOTA hand-held tester switches the ECM from the normal mode to the check mode or vice-versa, or if the ignition switch is turned from ON to ACC or OFF during the check mode, the DTCs and freeze frame data will be erased.

**3. Check Mode:****INSPECT DIAGNOSIS****HINT:**

TOYOTA hand-held tester only:

Compared to the normal mode, the check mode has further sensitivity to detect malfunctions.

Furthermore, the same diagnostic items which are detected in the normal mode can also be detected in the check mode.

Check the DTC.

- (1) Initial conditions
  - Battery positive voltage 11 V or more
  - Throttle valve fully closed
  - Transmission in the P or N position
  - A/C switched OFF
- (2) Turn the ignition switch OFF.
- (3) Prepare the TOYOTA hand-held tester.
- (4) Connect the TOYOTA hand-held tester to the DLC3 in the at the lower left of the instrument panel.
- (5) Turn the ignition switch ON and push the TOYOTA hand-held tester ON.

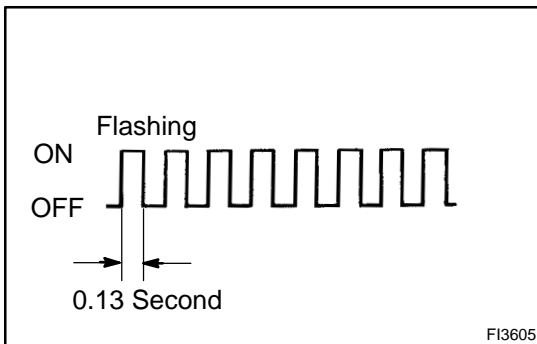

- (6) Switch the TOYOTA hand-held tester from the normal mode to the check mode. (Check that the MIL flashes.)

**NOTICE:**

If the TOYOTA hand-held tester switches the ECM from the normal mode to the check mode or vice-versa, or if the ignition switch is turned from ON to ACC or OFF during the check mode, the DTCs and freeze frame data will be erased.

- (7) Start the engine (The MIL goes off after the engine started.).
- (8) Simulate the conditions of the malfunction described by the customer.

**NOTICE:**

Leave the ignition switch ON until you have checked the DTCs, etc.

- (9) After simulating the malfunction conditions, use the TOYOTA hand-held tester diagnosis selector to check the DTCs and freeze frame data, etc.

**HINT:**

Take care not to turn the ignition switch OFF. Turning the ignition switch OFF switches the diagnosis system from the check mode to the normal mode, so all the DTCs, etc. are erased.

- (10) After checking the DTC, inspect the applicable circuit.

**4. FAIL-SAFE CHART**

If any of the following codes is recorded, the ECM enters fail-safe mode.

DTC No.	Fail-Safe Operation	Fail-Safe Deactivation Conditions
P0100	<ul style="list-style-type: none"> <li>• Ignition timing fixed at 5° BTDC</li> <li>• Injection time fixed</li> <li>Starting - - - - -11.6 msec.</li> <li>CTP switch ON - - - - 3.2 msec.</li> <li>CTP switch OFF - - - - 6.0 msec.</li> </ul>	Returned to normal condition
P0110	Intake air temperature fixed at 20°C (68°F)	Returned to normal condition
P0115	Engine coolant temperature fixed at 80°C (176°F)	Returned to normal condition
P0120	VTA fixed at 0°	The following condition must be repeated at least 2 times consecutively When closed throttle position switch is ON: VTA $\geq$ 0.1 V and $\leq$ 0.95 V
P0135* P0141	The heater circuit in which an abnormality is detected is turned off	Ignition switch OFF
P0325	Max. timing retardation	Ignition switch OFF
P0340	Fuel cut	Returned to normal condition
P1300 P1310	Fuel cut	Returned to normal condition

\*: California Spec.

**5. CHECK FOR INTERMITTENT PROBLEMS****HINT:**

TOYOTA hand-held tester only:

By putting the vehicle's ECM in the check mode, 1 trip detection logic is possible instead of 2 trip detection logic and sensitivity to detect open circuits is increased. This makes it easier to detect intermittent problems.

- (a) Clear the DTCs (See step 2).
- (b) Set the check mode (See step 3).
- (c) Perform a simulation test (See page [IN-18](#)).
- (d) Check the connector and terminal (See page [IN-28](#)).
- (e) Handle the connector (See page [IN-28](#)).

**6. BASIC INSPECTION**

When the malfunction code is not confirmed in the DTC check, troubleshooting should be performed in all the possible circuits considered as a cause of the problems. In many cases, by carrying out the basic engine check shown in the following flow chart, the location causing the problem can be found quickly and efficiently. Therefore, use of this check is essential to the engine troubleshooting.

<b>1</b>	<b>Is battery positive voltage 11 V or more when engine is stopped?</b>
----------	---

**NO**

**Charge or replace battery.**

**YES**

2001 TOYOTA TACOMA (RM835U)

**2 Is engine cranked?**

**NO**

Proceed to pages **ST-16** , **ST-18** , and continue to troubleshoot.

**YES**

**3 Does engine start?**

**NO**

Go to step NO TAG.

**YES**

**4 Check air filter.**

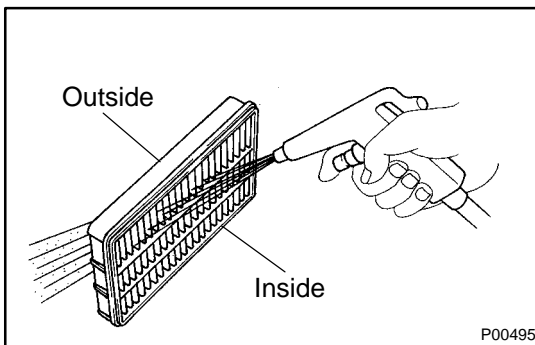

**PREPARATION:**

Remove the air filter.

**CHECK:**

Visually check that the air filter is not dirty nor excessive only.

**HINT:**

If necessary, clean the air filter with compressed air. First blow from inside thoroughly, then blow from outside of the air filter.

**NG**

Repair or replace.

**OK**

**5 Check idle speed.**

**PREPARATION:**

- Warm up the engine to the normal operating temperature.
- Switch off all the accessories.
- Switch off the A/C.
- Shift the transmission into the N position.
- Connect the OBD II scan tool or TOYOTA hand-held tester to the DLC3 of the vehicle.

**CHECK:**

Use the CURRENT DATA to check the idle speed.

**OK:**

**Idle speed: 650 - 750 rpm**

2001 TOYOTA TACOMA (RM835U)

NG

Proceed to problem symptoms table on page [DI-21](#) .

OK

## 6 Check ignition timing.

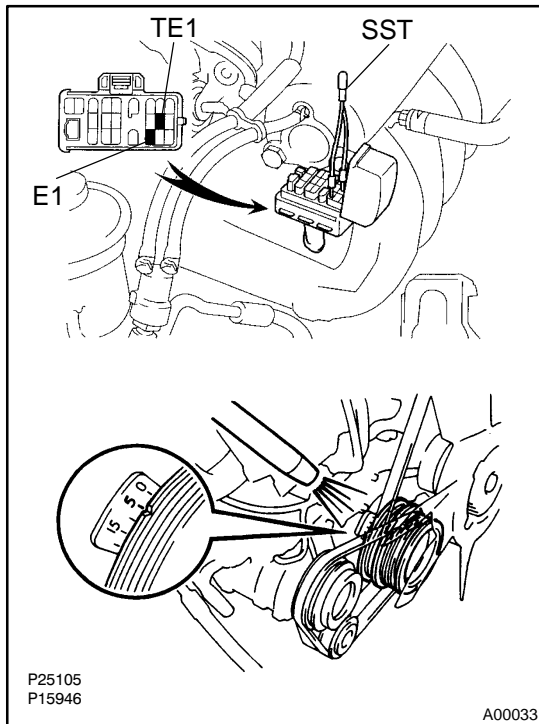

### PREPARATION:

- Warm up the engine to the normal operating temperature.
- Shift the transmission into the N position.
- Keep the engine speed at idle.
- Using SST, connect terminals TE1 and E1 of the DLC1. SST 09843-18020
- Using a timing light, connect the tester to the No.1 high-tension cord.

### CHECK:

Check ignition timing.

### OK:

Ignition timing: 3 - 7° BTDC at idle

NG

Proceed to page [IG-1](#) , and continue to trouble-shoot.

OK

Proceed to problem symptoms table on page [DI-21](#) .

## 7 Check fuel pressure.

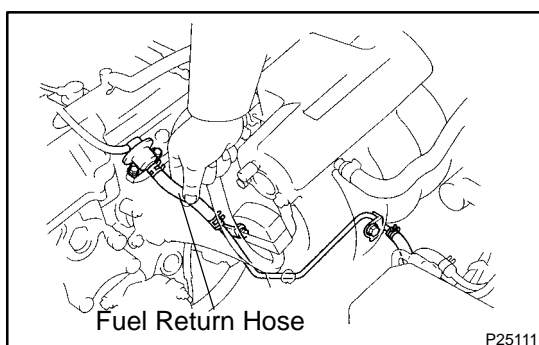

### PREPARATION:

- Be sure that the enough fuel is in the tank.
- Connect the TOYOTA hand-held tester to the DLC3.
- Turn the ignition switch ON and push the TOYOTA hand-held tester main switch ON.
- Use the ACTIVE TEST mode to operate the fuel pump.
- Please refer to the TOYOTA hand-held tester operator's manual for further details.



- (f) If you have no TOYOTA hand-held tester, connect the positive (+) and negative (-) leads from the battery to the fuel pump connector (See page SF-5 ).

**CHECK:**

Check for the fuel pressure in the fuel return hose when it is pinched by hand.

**HINT:**

At this time, you will hear the fuel flowing noise.

<b>NG</b>	<b>Proceed to page SF-5 , and continue to trouble-shoot.</b>
-----------	--

<b>OK</b>
-----------

<b>8</b>	<b>Check for spark.</b>
----------	-------------------------

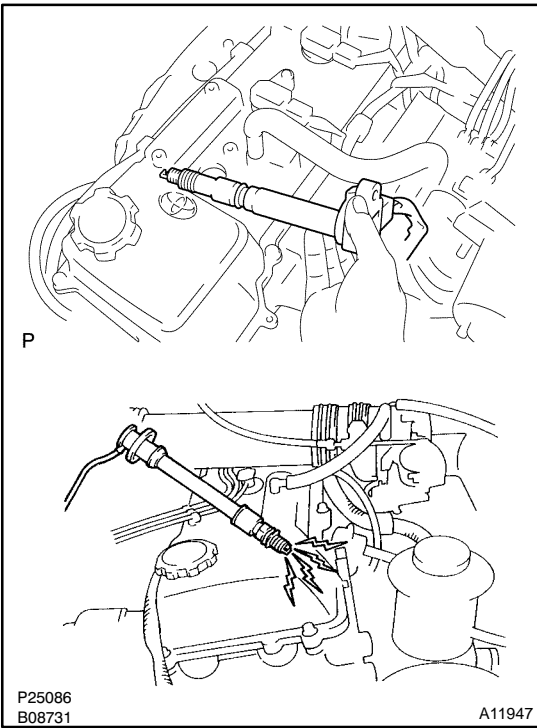

**California Spec.:**

**PREPARATION:**

- (a) Remove the ignition coil.
- (b) Remove the spark plug.
- (c) Install the spark plug to the ignition coil.
- (d) Disconnect the injector connector.
- (e) Ground the spark plug.

**CHECK:**

Check if spark occurs while the engine is being cranked.

**NOTICE:**

**To prevent excess fuel from being injected from the injectors during this test, don't crank the engine for more than 5 - 10 seconds at a time.**

**Except California Spec.:**

**PREPARATION:**

- (a) Disconnect the high-tension cord from the spark plug.
- (b) Remove the spark plug.
- (c) Install the spark plug to the high-tension cord.
- (d) Disconnect the injector connector.
- (e) Ground the spark plug.

**CHECK:**

Check if spark occurs while the engine is being cranked.

**NOTICE:**

**To prevent excess fuel from being injected from the injectors during this test, don't crank the engine for more than 5 - 10 seconds at a time.**

<b>NG</b>	<b>Proceed to page IG-1 , and continue to trouble-shoot.</b>
-----------	--

<b>OK</b>
-----------

Proceed to problem symptoms table on page  
DI-21 .

## 7. ENGINE OPERATING CONDITION

### NOTICE:

The values given below for "Normal Condition" are representative values, so a vehicle may still be normal even if its value differs from those listed here. So do not solely depend on the "Normal Condition" here when deciding whether a part is faulty or not.

(a) CARB mandated signals.

TOYOTA hand-held tester display	Measurement Item	Normal Condition*
FUEL SYS #1	Fuel System Bank 1 OPEN: Air-fuel ratio feedback stopped CLOSED: Air-fuel ratio feedback operating	Idling after warming up: CLOSED
CALC LOAD	Calculator Load: Current intake air volume as a proportion of max. intake air volume	Idling: 2RZ-FE: 17.2 - 24.6 % 3RZ-FE: 15.9 - 22.8 % Racing without load (2,500 rpm): 2RZ-FE: 16.4 - 23.1 % 3RZ-FE: 15.2 - 22.1 %
COOLANT TEMP	Engine Coolant Temp. Sensor Value	After warming up: 80 - 95°C (176 - 203°F)
SHORT FT #1	Short-term Fuel Trim Bank 1	0 ± 20 %
LONG FT #1	Long-term Fuel Trim Bank 1	0 ± 20 %
ENGINE SPD	Engine Speed	Idling: 650 - 750 rpm
VEHICLE SPD	Vehicle Speed	Vehicle stopped: 0 km/h (0 mph)
IGN ADVANCE	Ignition Advance: Ignition Timing of Cylinder No.1	Idling: 2RZ-FE: BTDC 5 - 17° 3RZ-FE: BTDC 4 - 17°
INTAKE AIR	Intake Air Temp. Sensor Value	Equivalent to ambient temperature
MAF	Air Flow Rate Through Mass Air Flow Meter	Idling: 2.7 - 3.9 gm/sec. Racing without load (2,500 rpm): 2RZ-FE: 9.2 - 12.9 gm/sec. 3RZ-FE: 9.2 - 13.3 gm/sec.
THROTTLE POS	Voltage Output of Throttle Position Sensor Calculated as a percentage: 0 V → 0 %, 5 V → 100 %	Throttle fully closed: 7 - 11 % Throttle fully open: 65 - 75 %
O2S B1 S1	Voltage Output of Oxygen Sensor Bank 1 Sensor 1	Idling: 0.1 - 0.9 V (0.56 - 0.76 V*2)
O2FT B1 S1	Oxygen Sensor Fuel Trim Bank 1 Sensor 1 (Same as SHORT FT #1)	0 ± 20 %
O2S B1 S2	Voltage Output of Oxygen Sensor Bank 1 Sensor 2	Driving (50 km/h, 31 mph): 0.1 - 0.9 V
A/FS B1 S1*3	Voltage Output of A/F Sensor Bank 1 Sensor 1	Idling: 2.8 - 3.8 V
A/FS B2 S1*3	Voltage Output of A/F Sensor Bank 2 Sensor 1	Idling: 2.8 - 3.8 V
A/FFT B1 S1*3	A/F Sensor Fuel Trim Bank 1 Sensor 1 (Same as SHORT FT #1)	0 ± 20 %

\*1: If no conditions are specifically stated for "Idling", it means the shift lever is at the N or P position, the A/C switch is OFF and all accessory switches are OFF.

\*2: Only for Calif. When you use the OBD II scan tool (excluding TOYOTA hand-held tester).

\*3: Only for Calif. When you use the TOYOTA hand-held tester.

## (b) TOYOTA enhanced signals.

TOYOTA hand-held tester display	Measurement Item	Normal Condition*
MISFIRE RPM	Engine RPM for first misfire range	Misfire 0: 0 rpm
MISFIRE LOAD	Engine load for first misfire range	Misfire 0: 0 g/r
INJECTOR	Fuel injection time for cylinder No.1	Idling: 2RZ-FE: 2.6 - 4.6 ms 3RZ-FE: 2.5 - 4.3 ms
IAC DUTY RATIO	Intake Air Control Valve Duty Ratio Opening ratio rotary solenoid type IAC valve	Idling: 24.8 - 50.0 %
STARTER SIG	Starter Signal	Cranking: ON
CTP SW	Closed Throttle Position Switch Signal	Throttle Fully Closed: ON
A/C SIG	A/C Switch Signal	A/C ON: ON
STOP LIGHT SW	Stop Light Switch Signal	Stop light switch ON: ON
FC IDL	Fuel Cut Idle: Fuel cut when throttle valve fully closed, during deceleration	Fuel cut operating: ON
FC TAU	Fuel Cut TAU: Fuel cut during very light load	Fuel cut operating: ON
CYL#1, CYL#2, CYL#3, CYL#4	Abnormal revolution variation for each cylinder	0 %
IGNITION	Total number of ignition for every 1,000 revolutions	0 - 2,000
EGRT GAS	EGR Gas Temp. Sensor Value	EGR not operating: Temp. between intake air temp. and engine coolant temp.
EGR SYSTEM*2	EGR System Operating Condition	Idling: OFF
A/C CUT SIG	A/C Cut Signal	A/C S/W OFF: ON
FUEL PUMP	Fuel Pump Signal	Idling: ON
EVAP (PURGE) VSV	EVAP VSV Signal	Idling: Below 30 %
VAPOR PRESS VSV	Vapor Pressure VSV Signal	VSV operating: ON (TANK)
TOTAL FT B1	Total Fuel Trim Bank 1: Average value for fuel trim system of bank 1	Idling: 0.8 - 1.2 V
O2 LR B1 S1*3	Oxygen Sensor Lean Rich Bank 1 Sensor 1: Response time for oxygen sensor output to switch from lean to rich	Idling after warming up: 0 - 1,000 msec.
O2 RL B1 S1*3	Oxygen Sensor Rich Lean Bank 1 Sensor 1: Response time for oxygen sensor output to switch from rich to lean	Idling after warming up: 0 - 1,000 msec.

\*1: If no conditions are specifically stated for "Idling", it means the shift lever is at N or P position, the A/C switch is OFF and all accessory switches are OFF.

\*2: Except 2RZ-FE for California Spec.

\*3: Except California Spec.